

**MULD
KING**®

宇星模王

宇星车模
MODELS ★ **NO. P1**

13090SD

3392+ Pcs/Pza



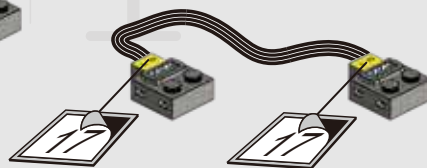
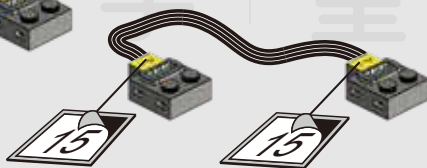
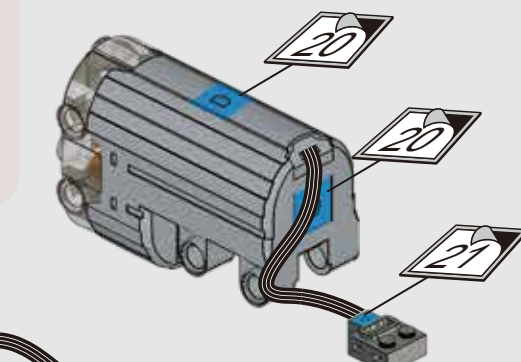
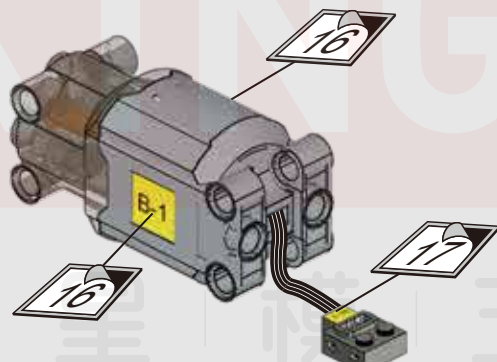
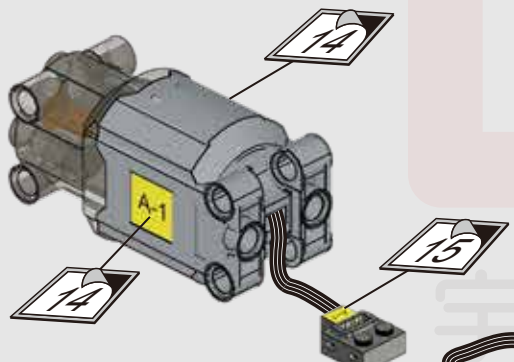
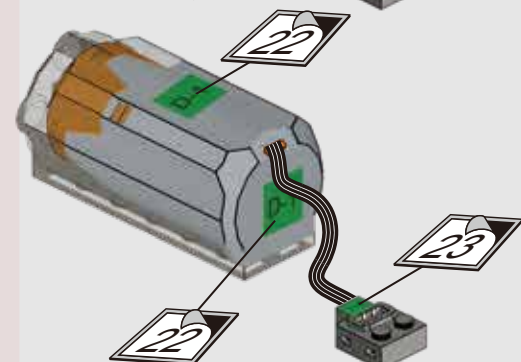
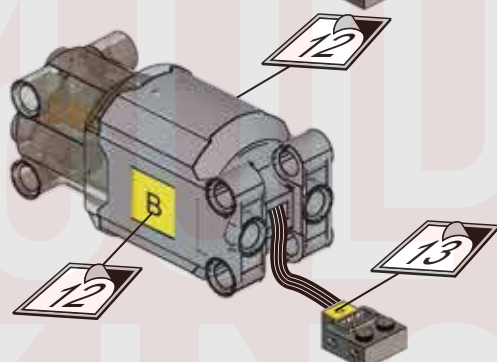
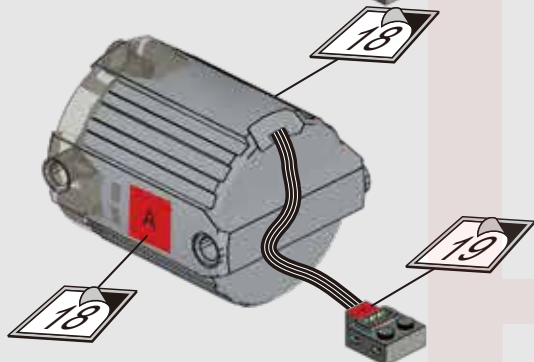
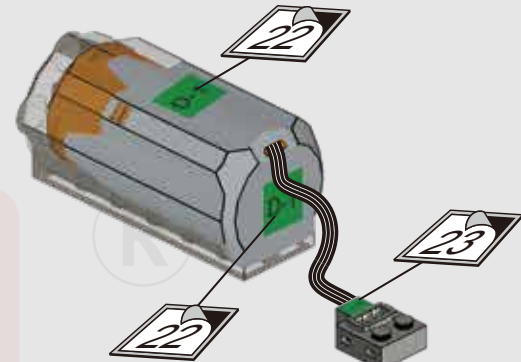
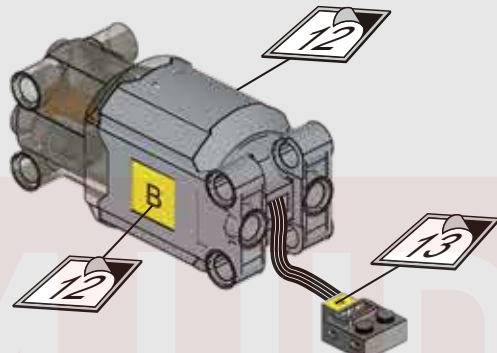
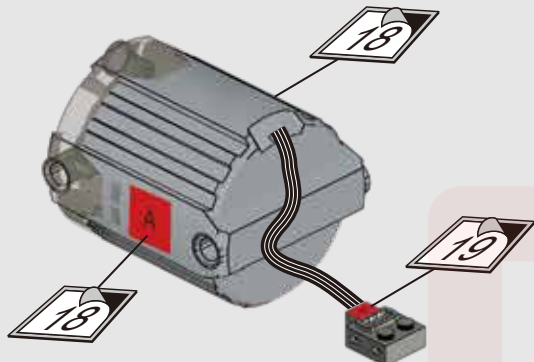

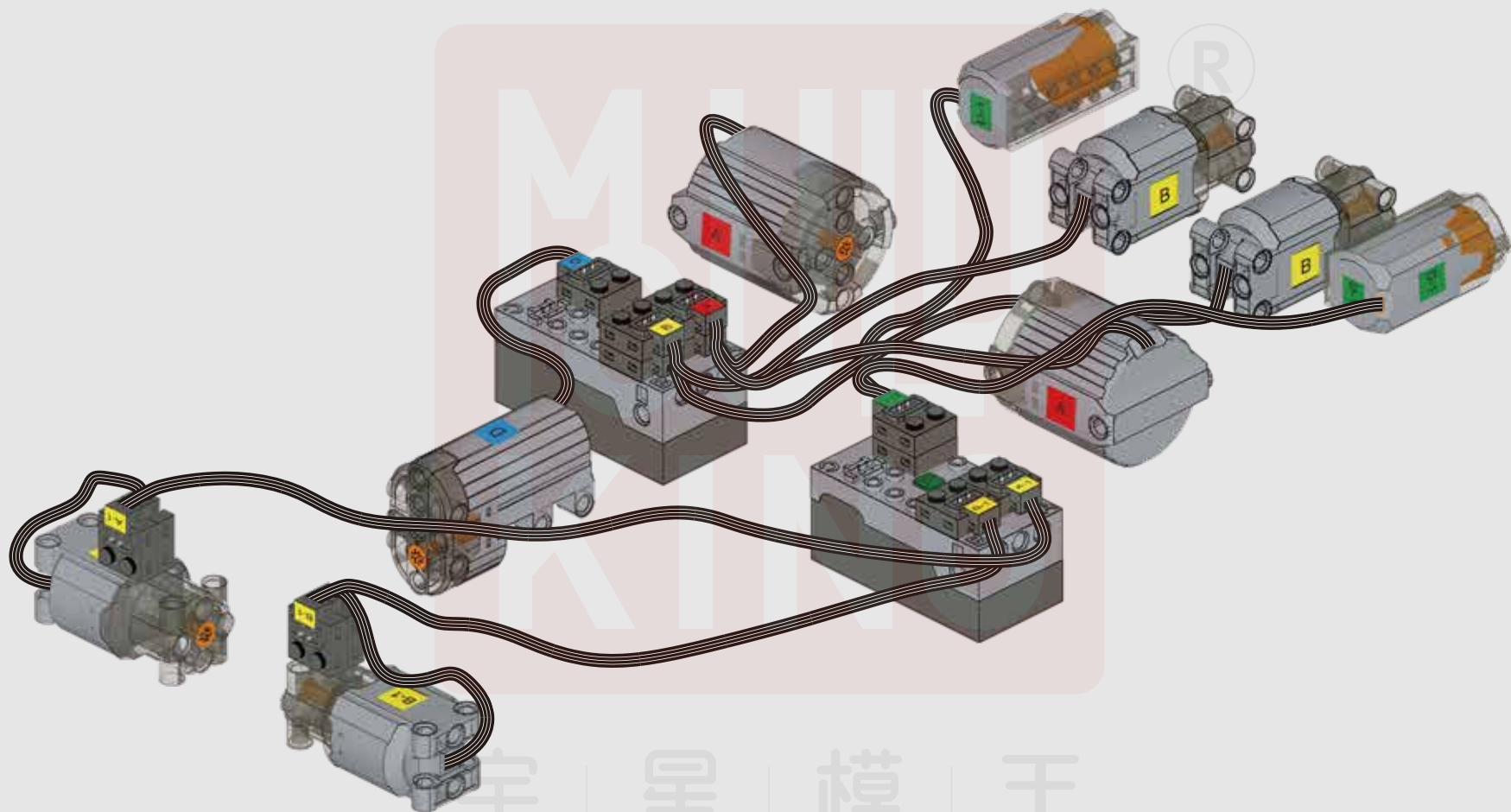

宇 | 星 | 模 | 王

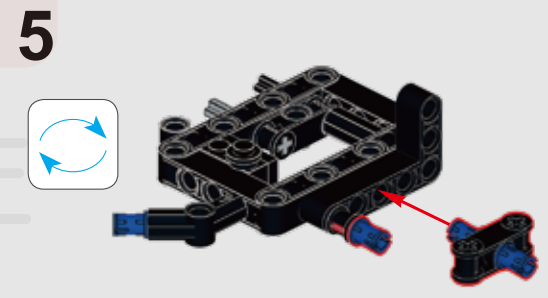
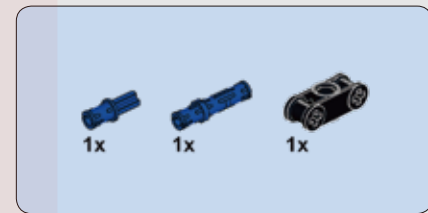
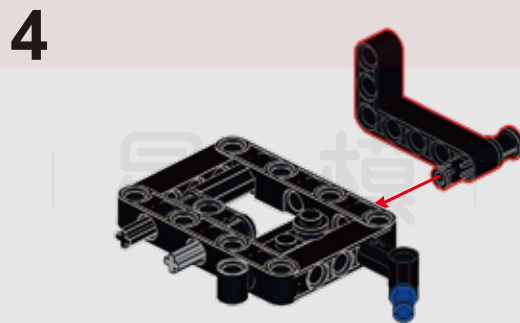
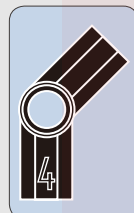
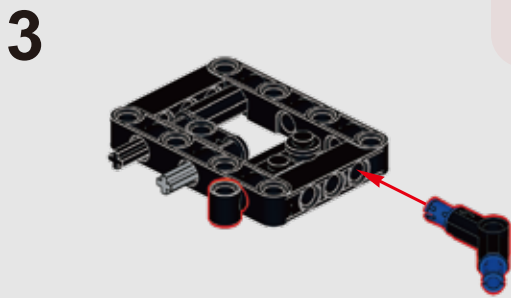
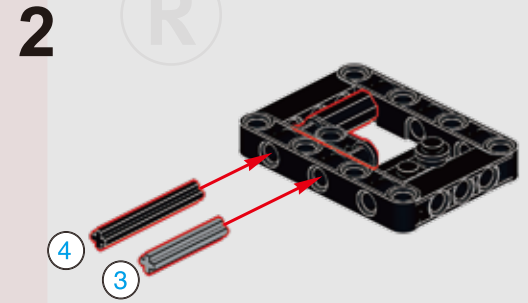
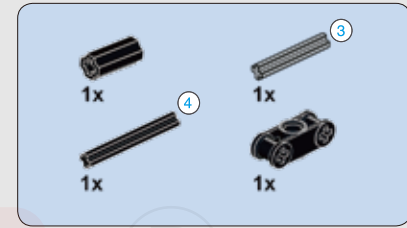
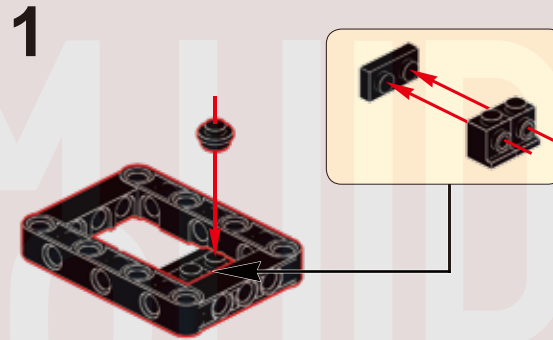
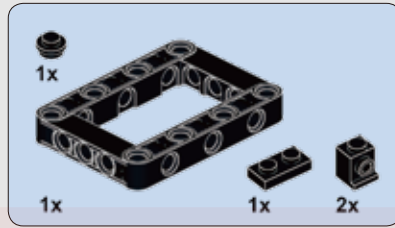
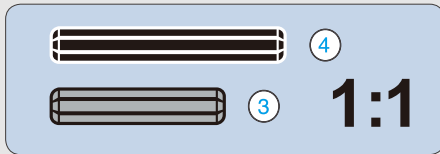
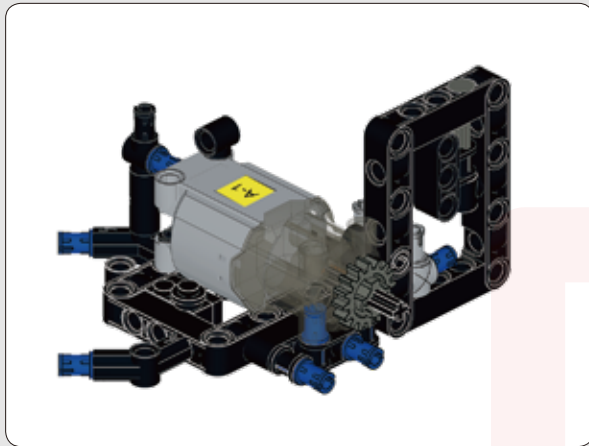



6

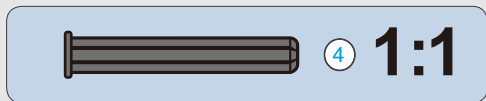
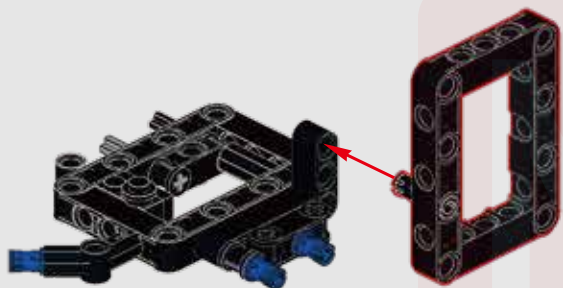

7

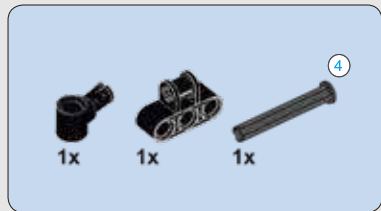
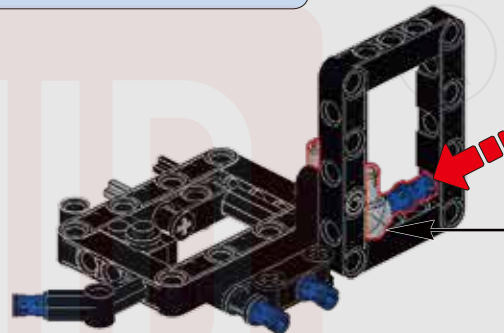

8

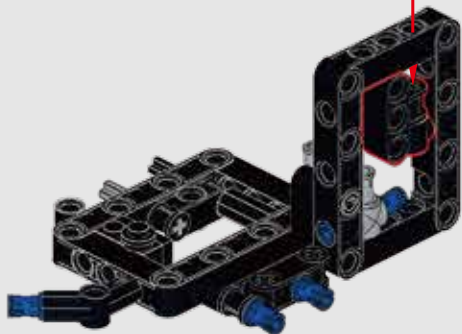

9

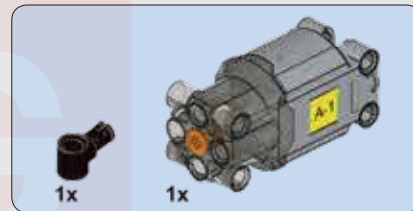
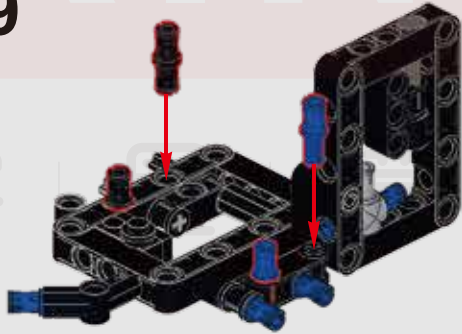

10

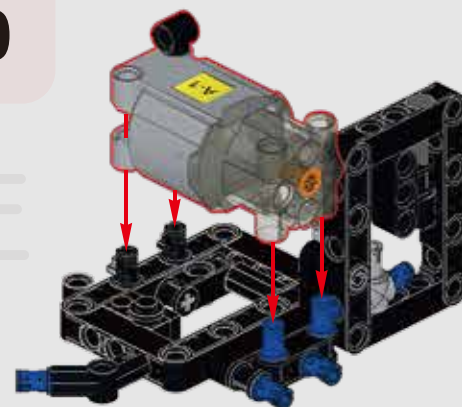

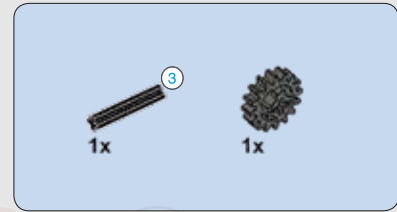
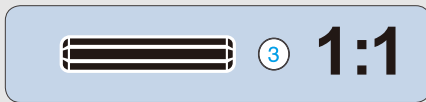

11

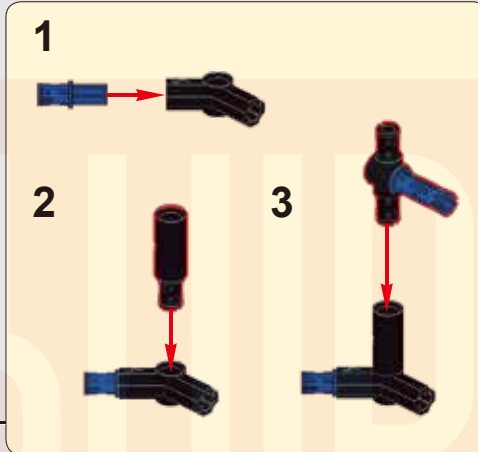
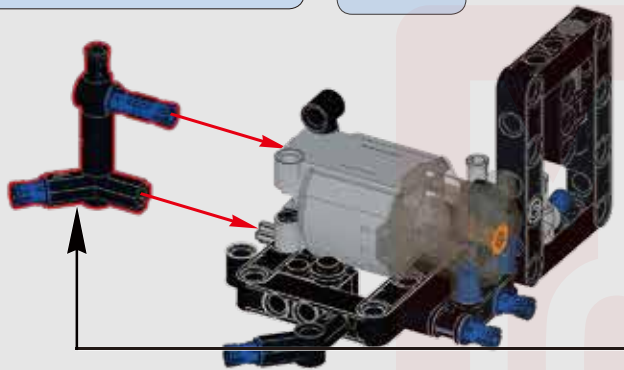

12

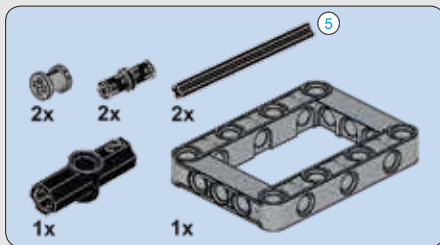
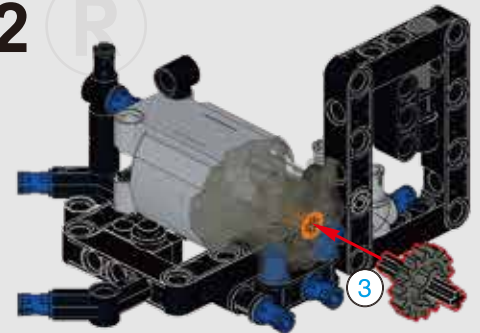

13

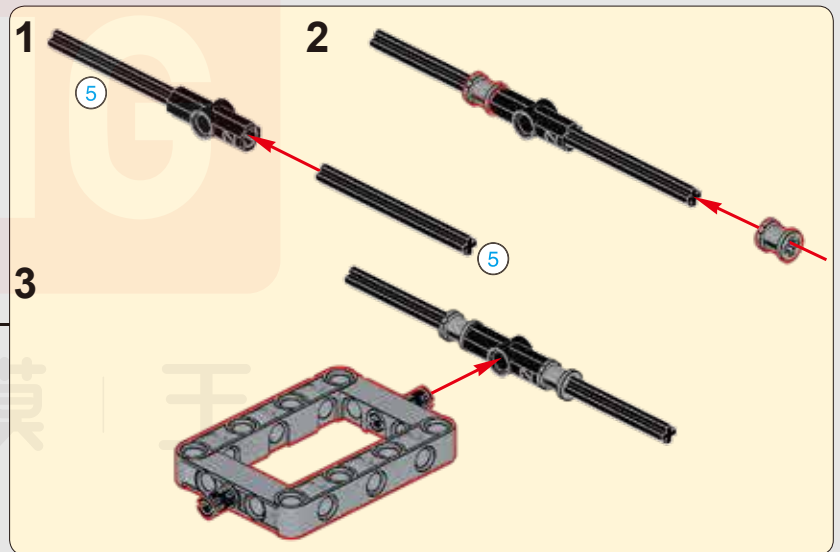
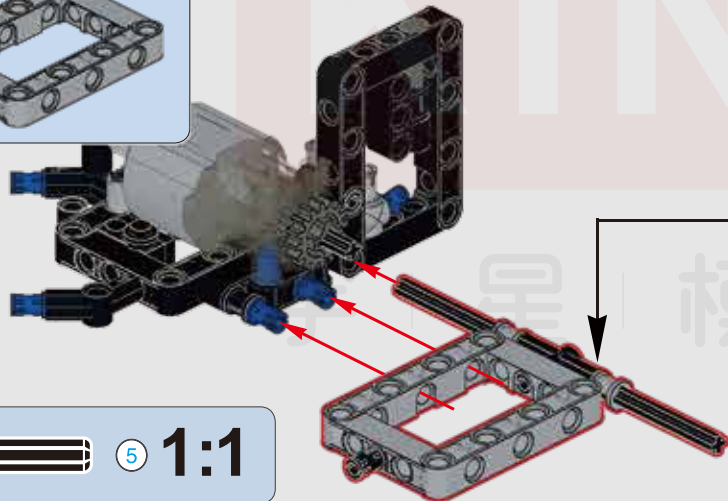

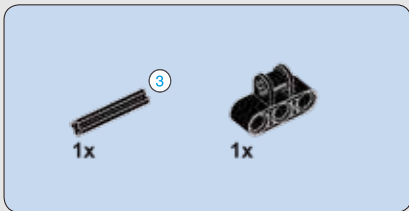

14



15

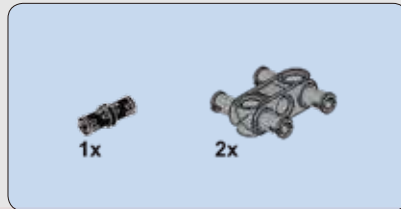
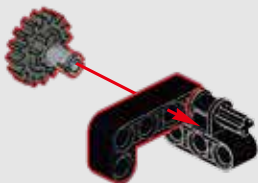

16

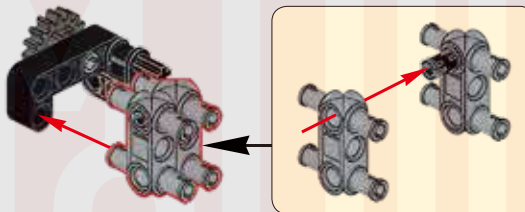

17

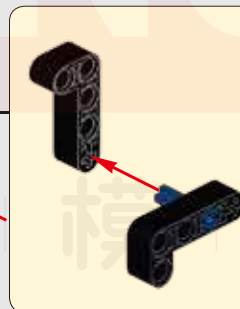

18



19

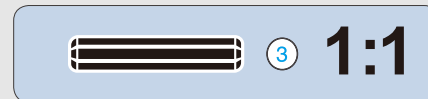
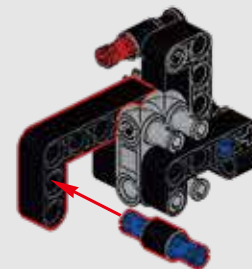

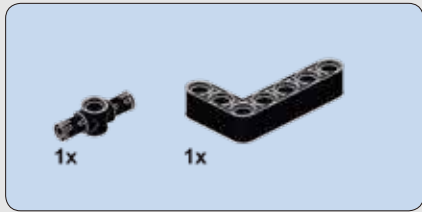

20

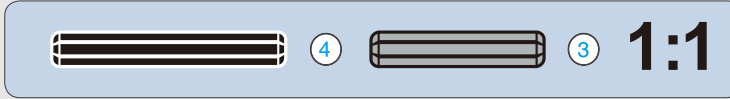
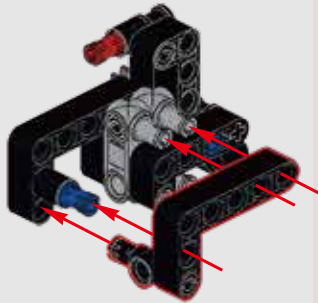

21

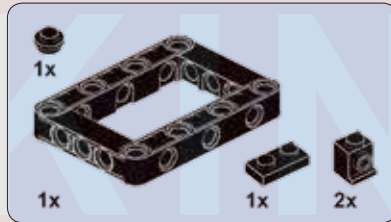
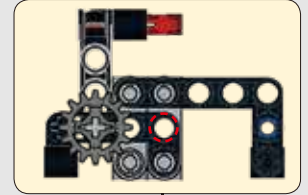
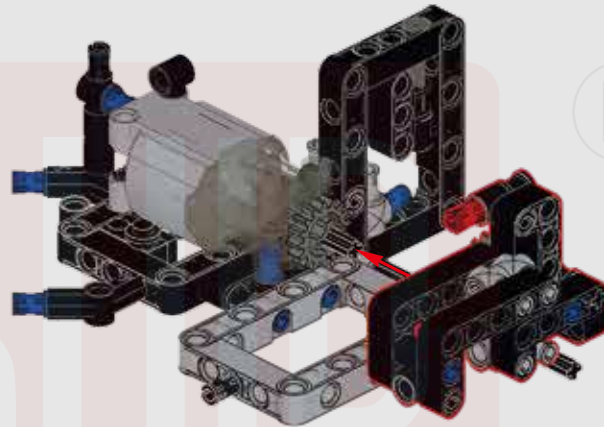

22

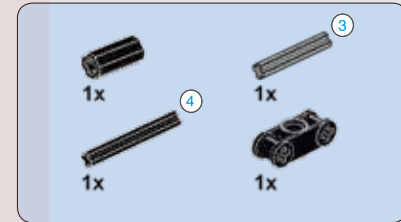
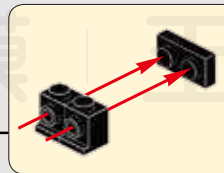
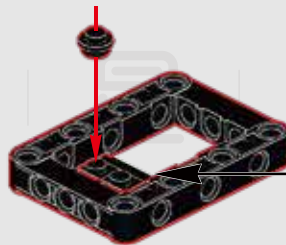

23

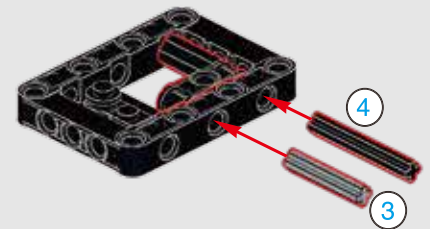

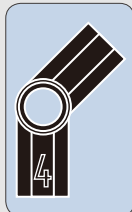
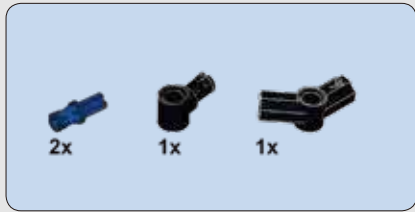

24

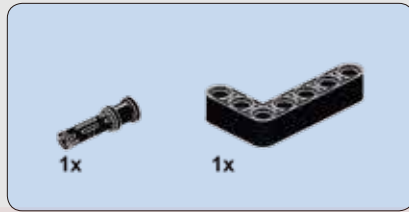
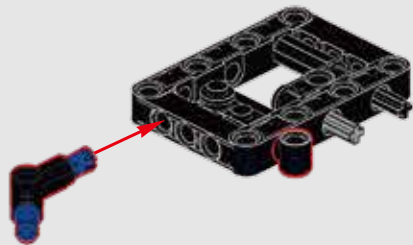

25

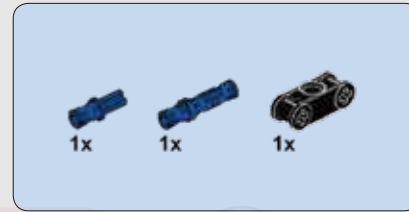
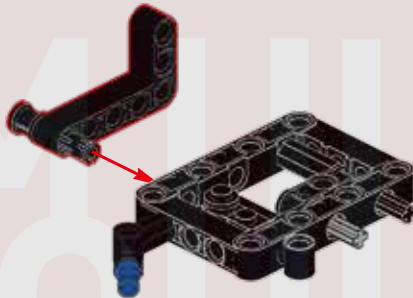

26

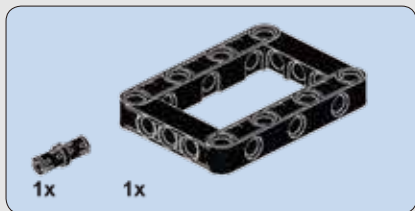
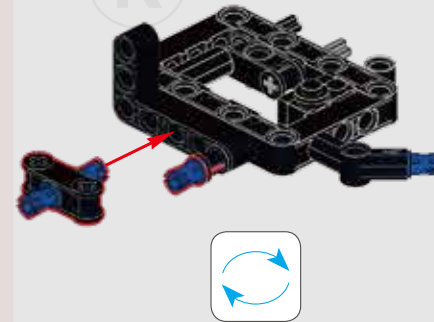

27

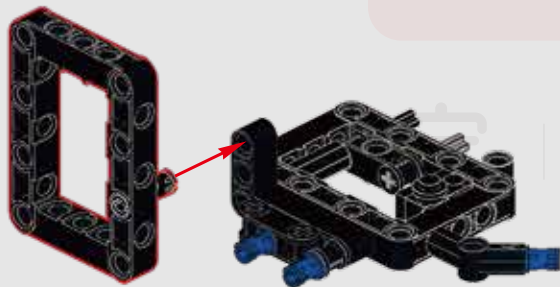

28

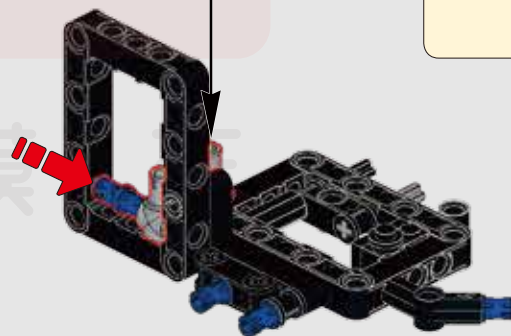

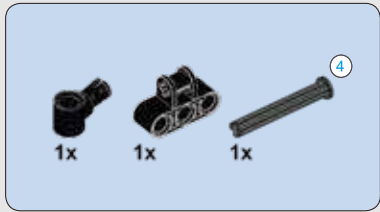

29

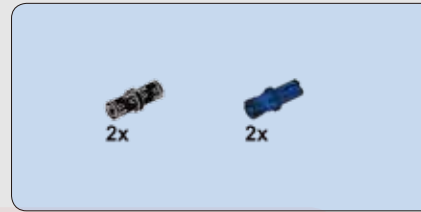
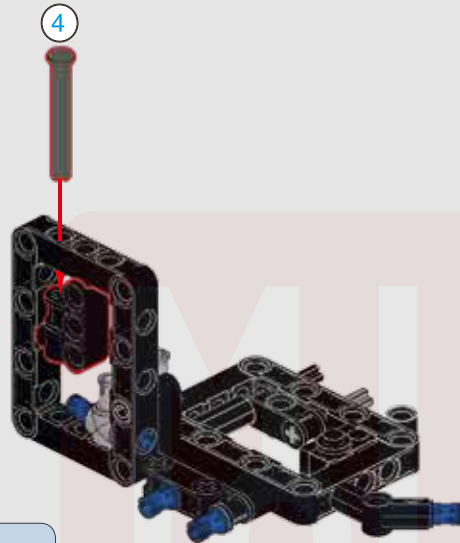

30

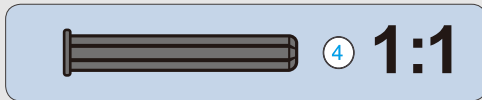
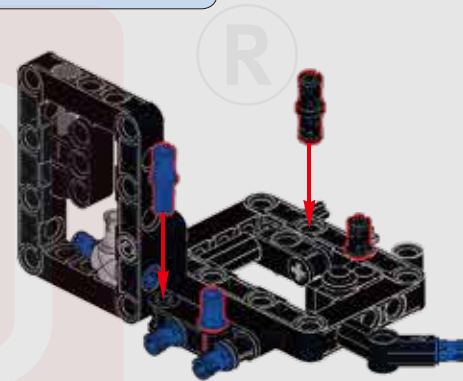

31

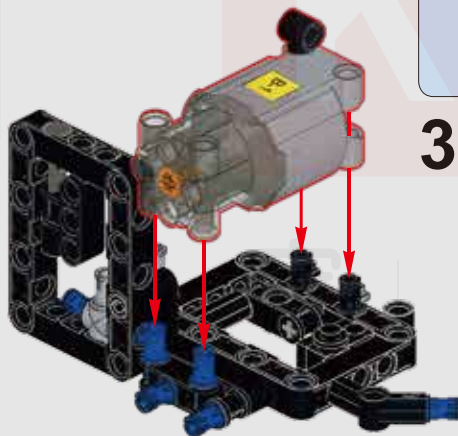
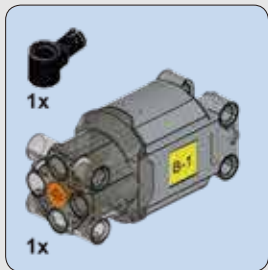

32

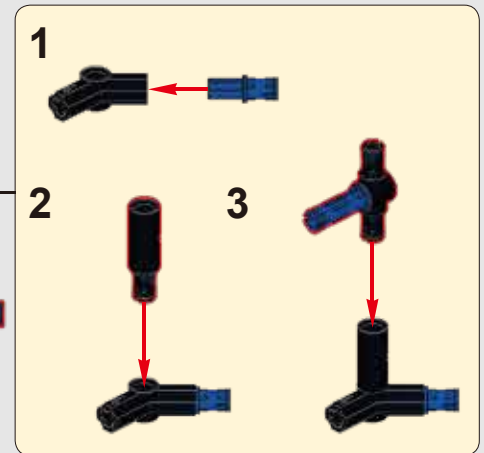
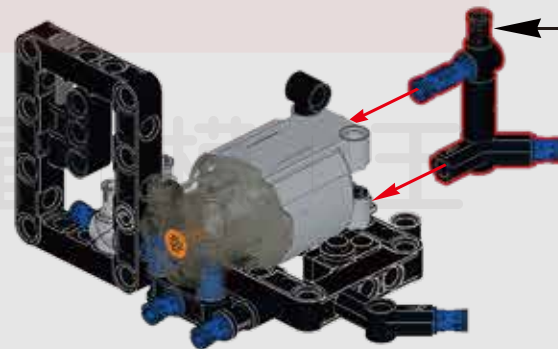

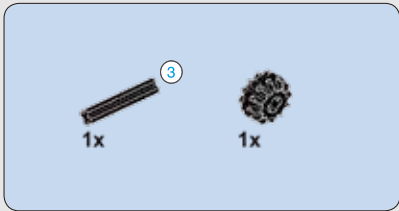

33

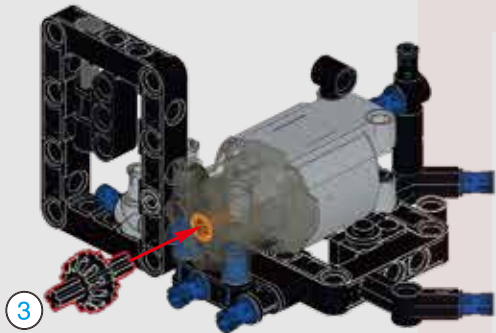

34

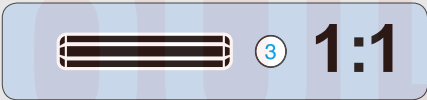
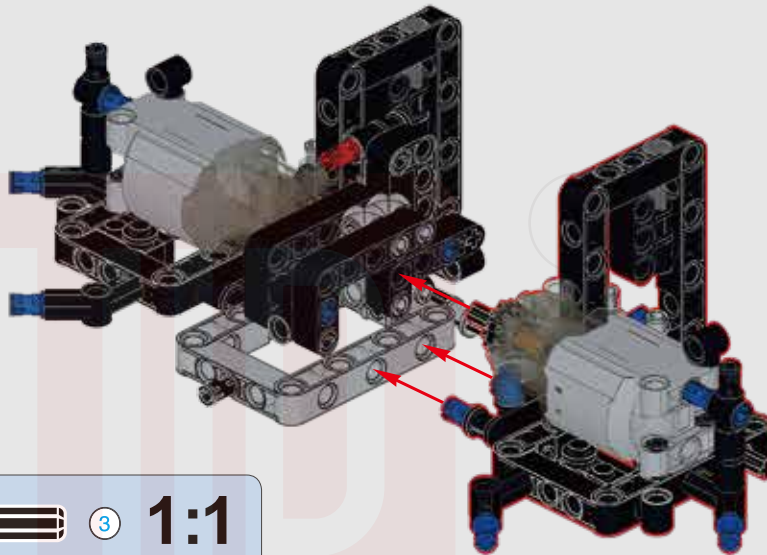

35

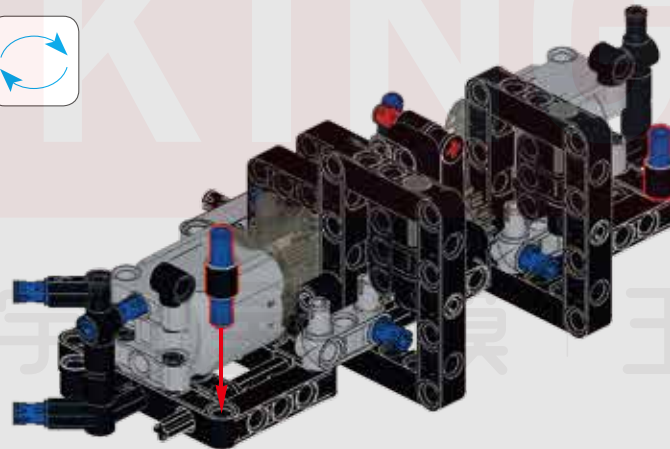
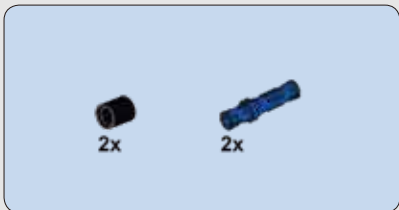

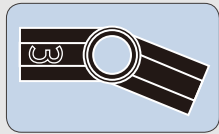
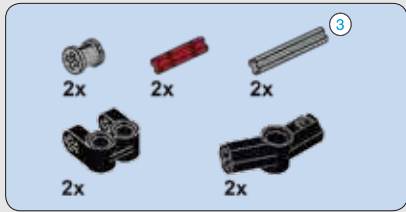

36

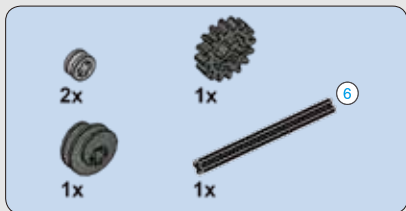
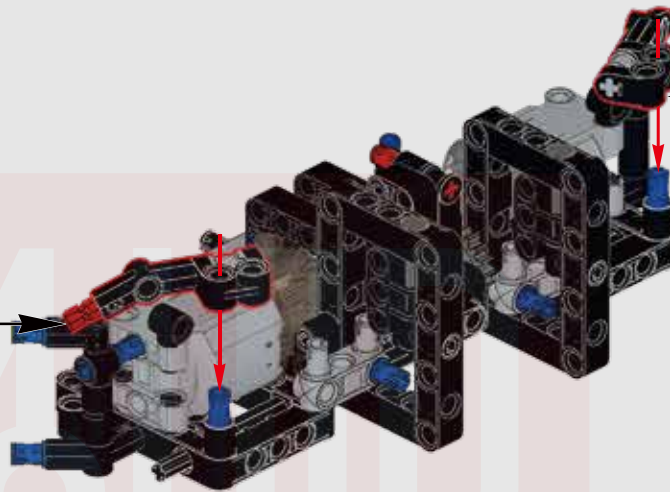
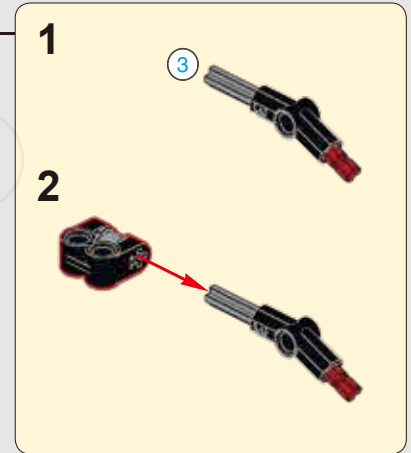
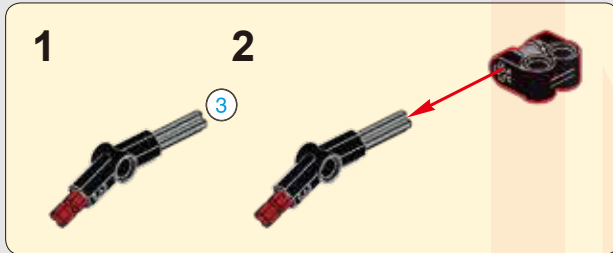

37

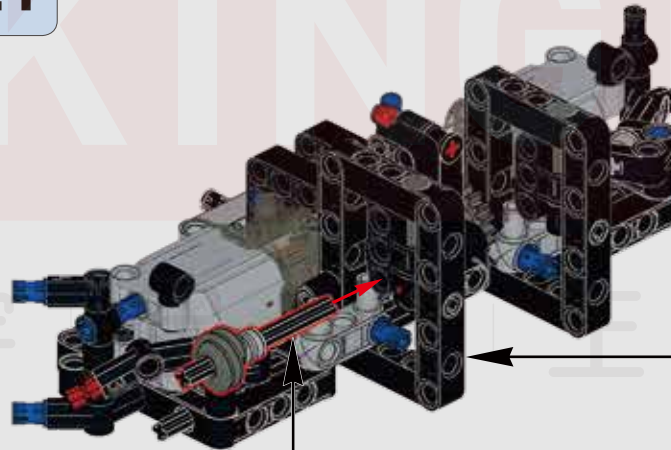
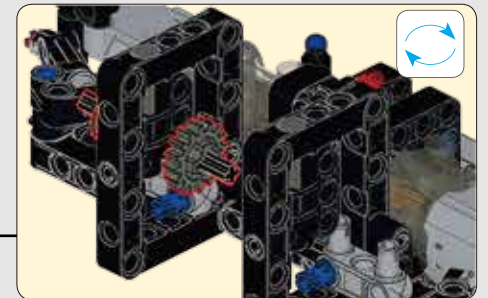
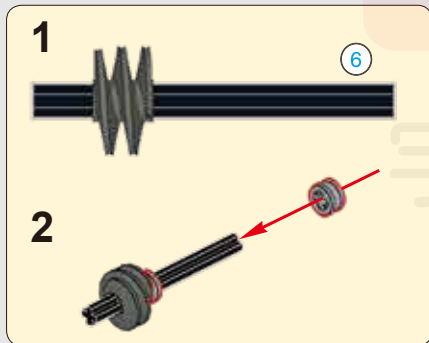

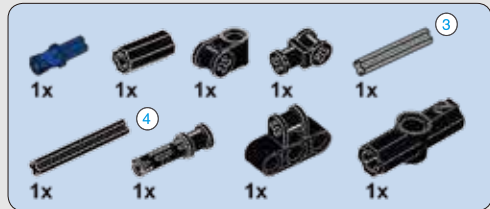

38

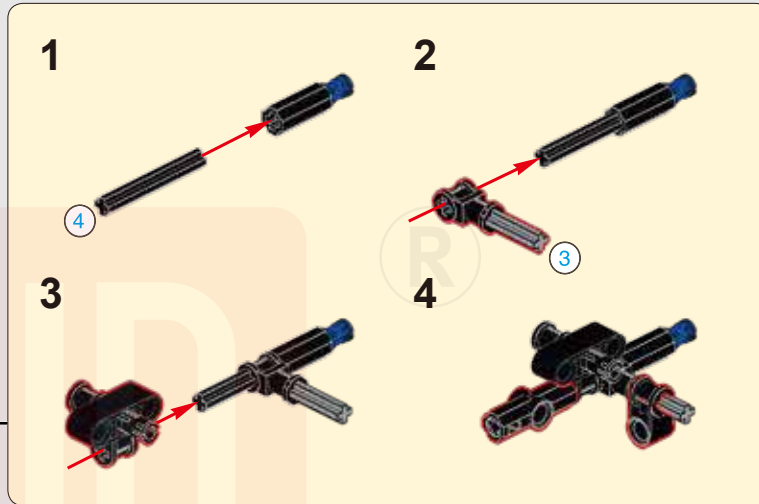
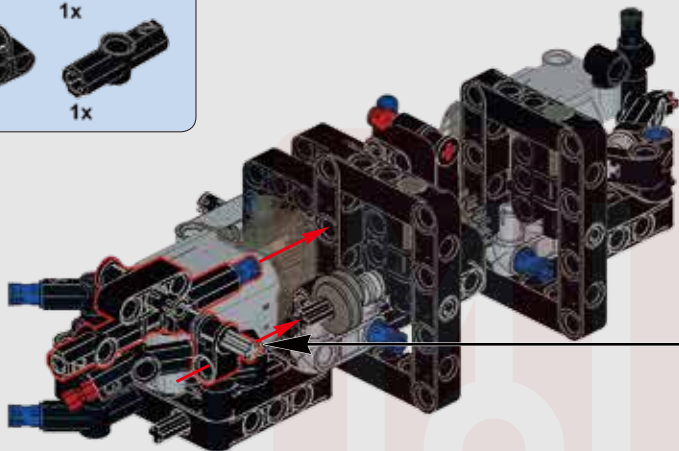

39

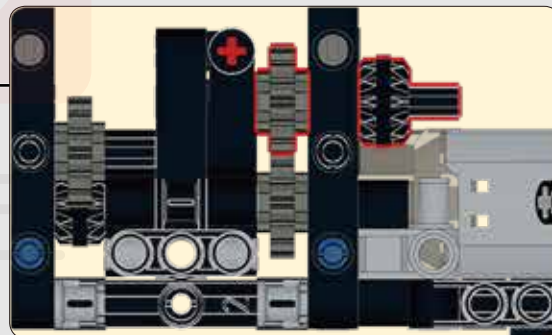
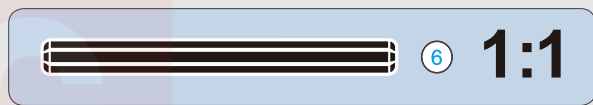
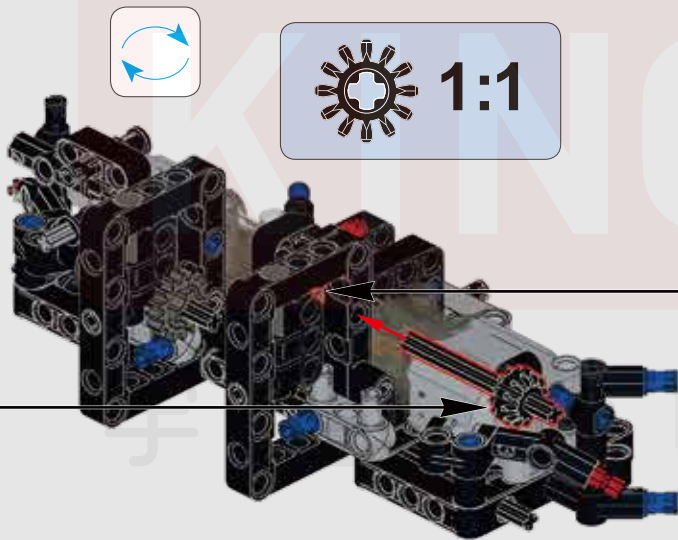

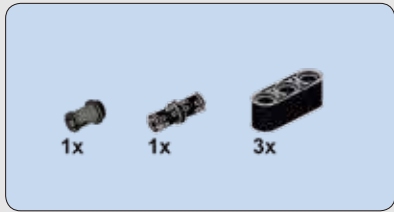

40

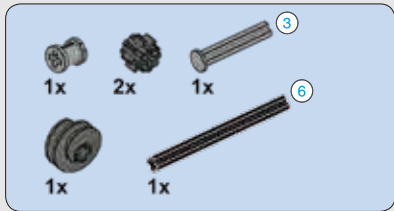
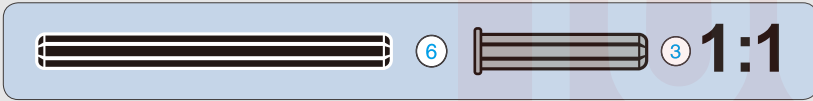
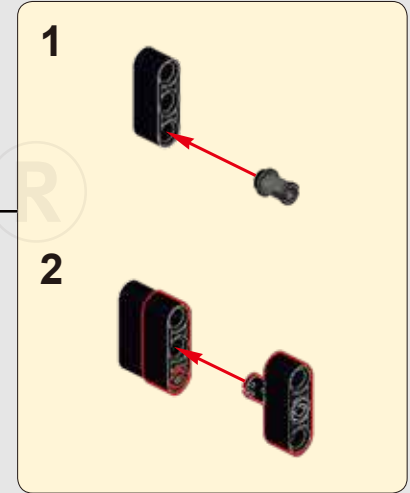
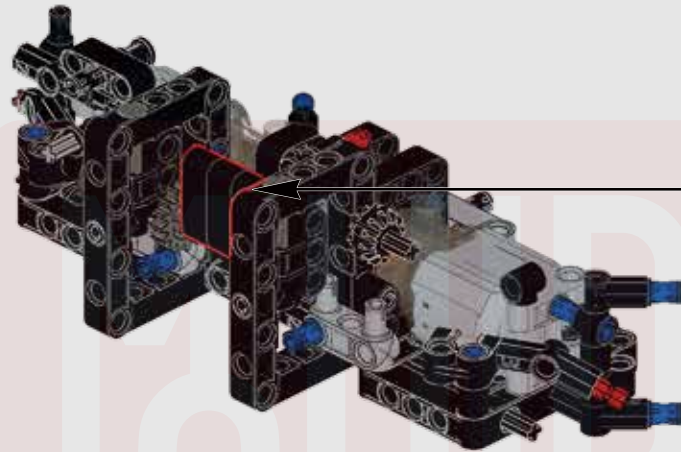

41

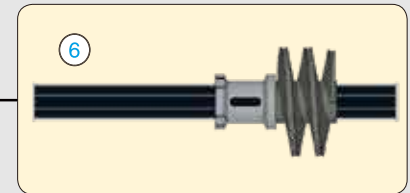
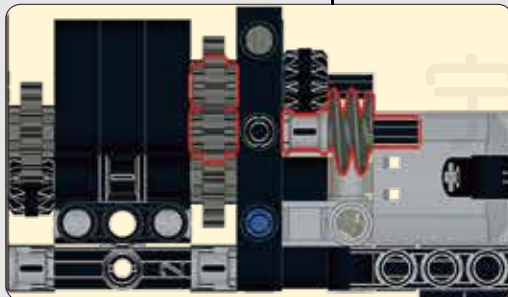
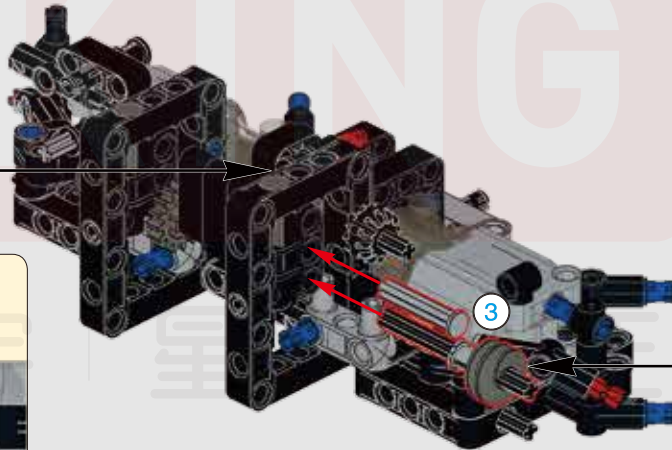

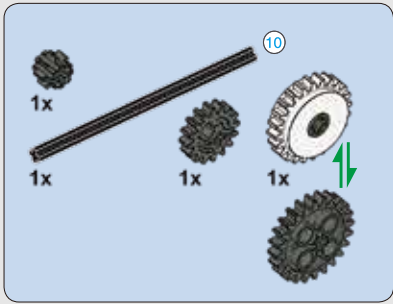

42

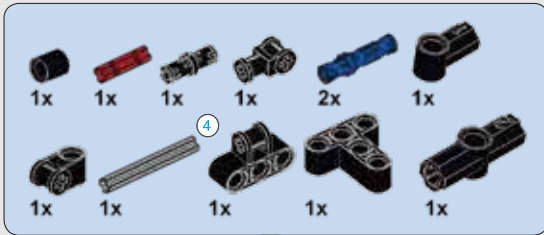
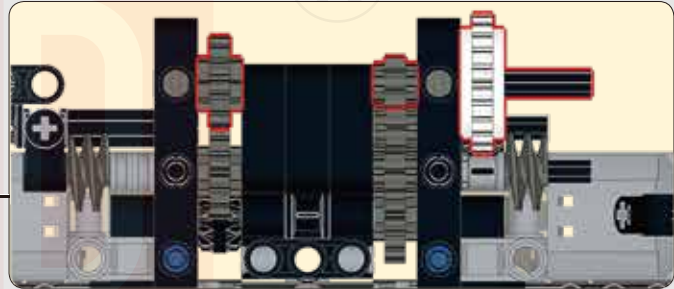
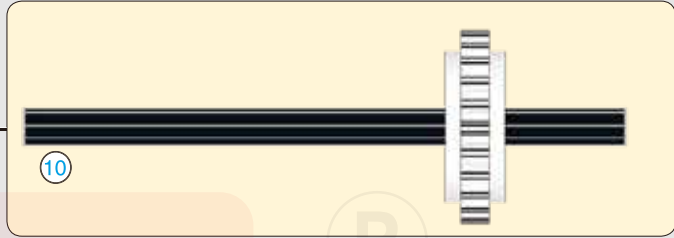
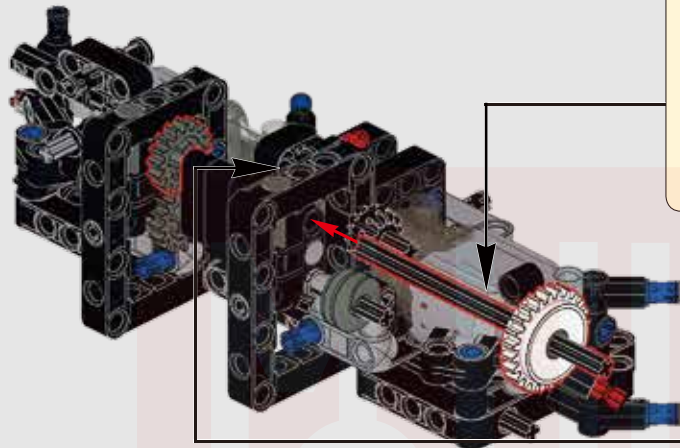

43

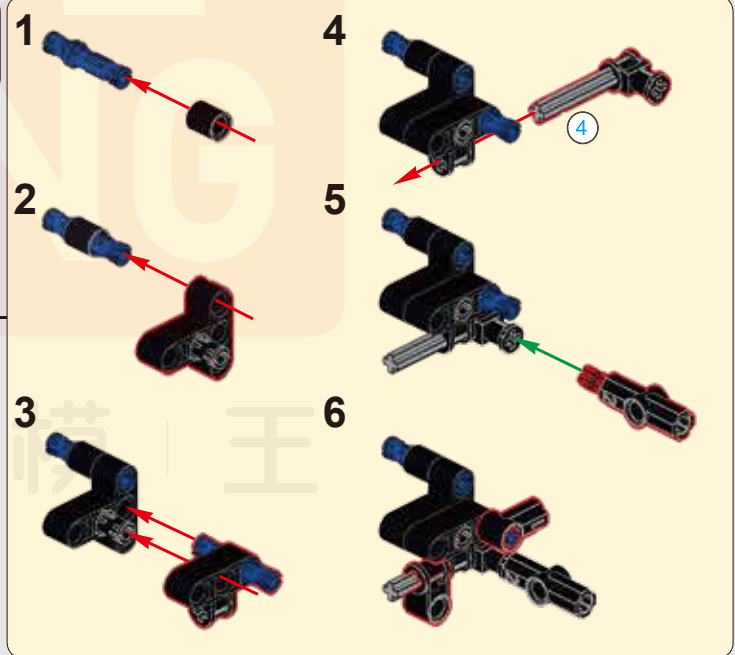
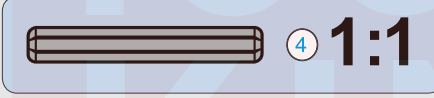
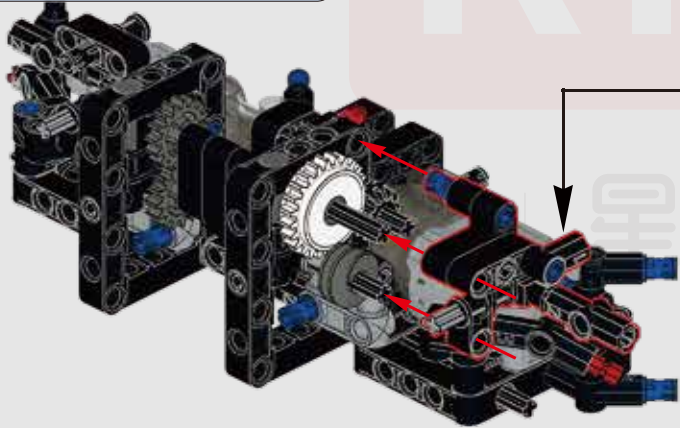

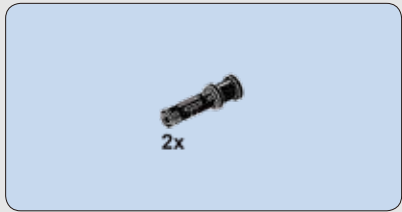

44

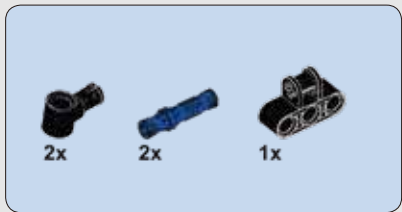
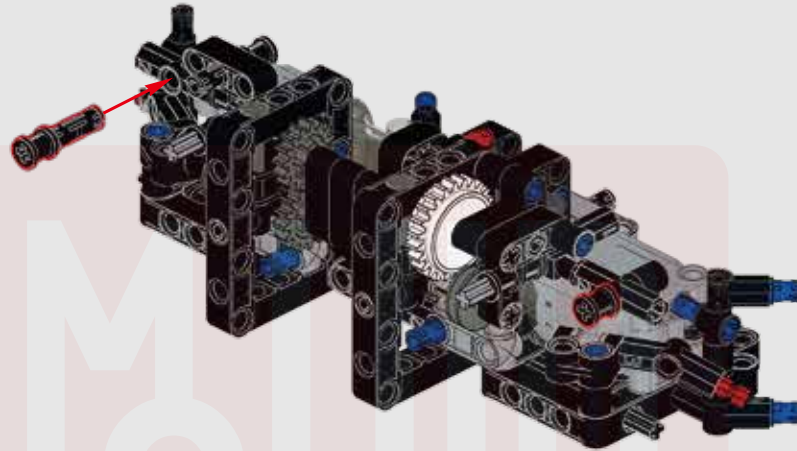

45

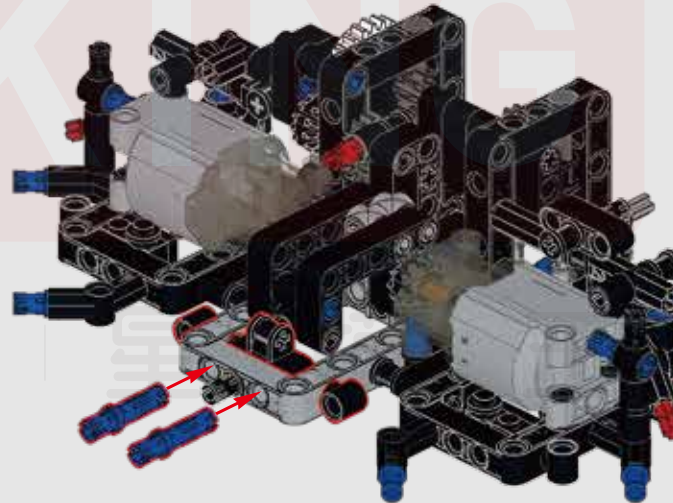

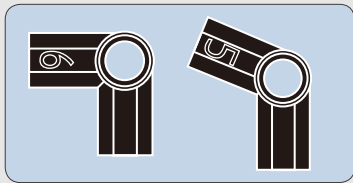
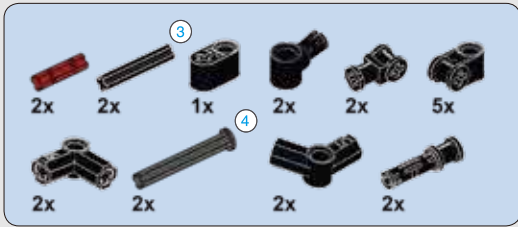

46

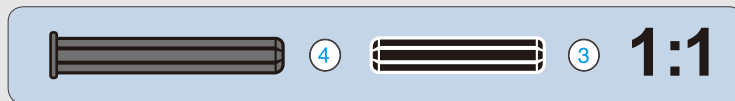
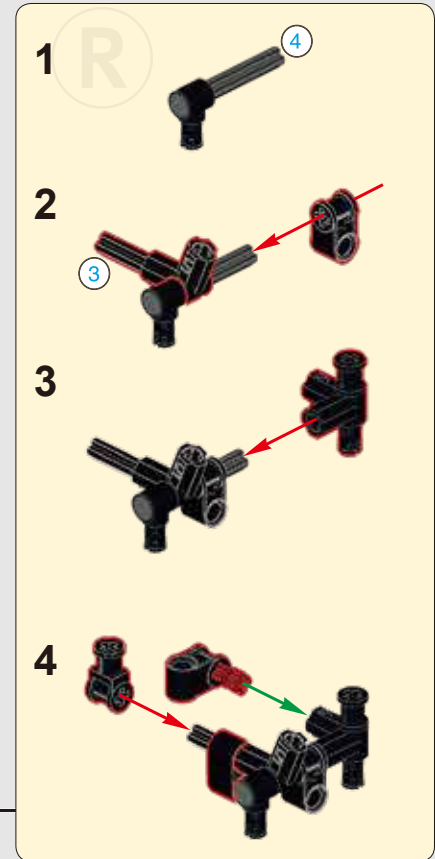
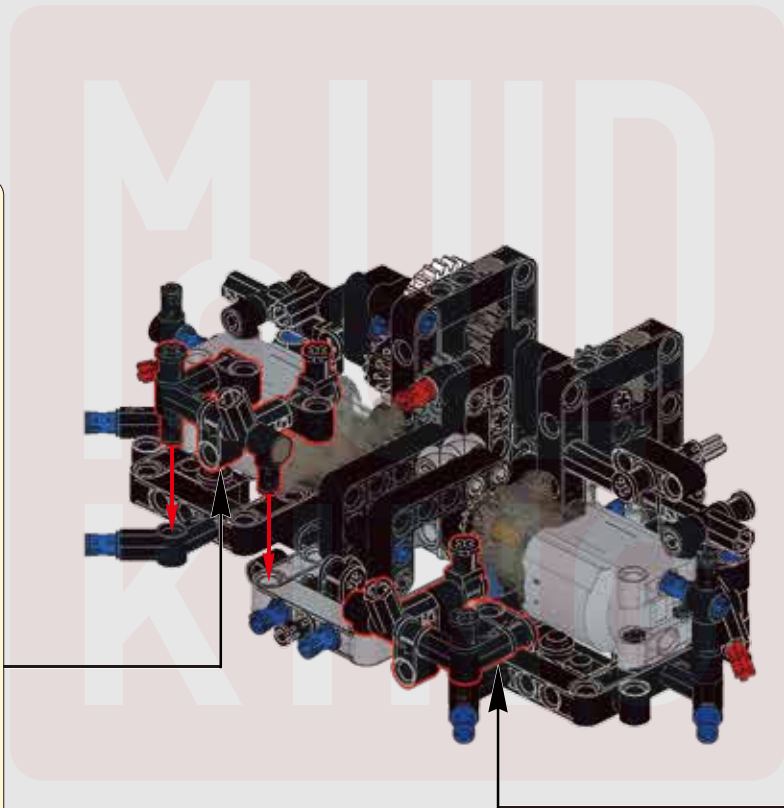
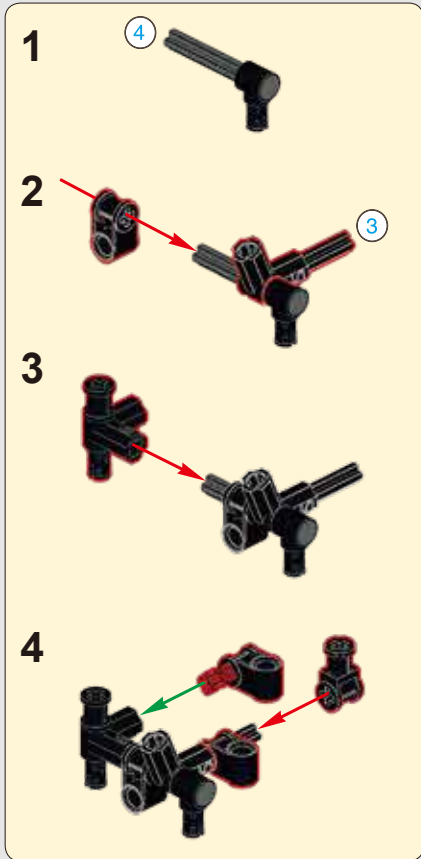

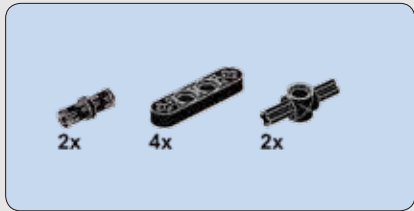

47

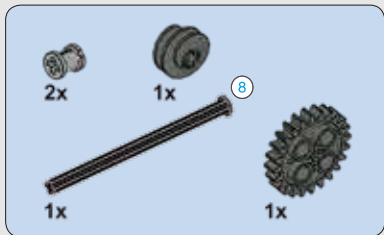
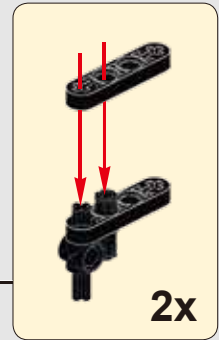
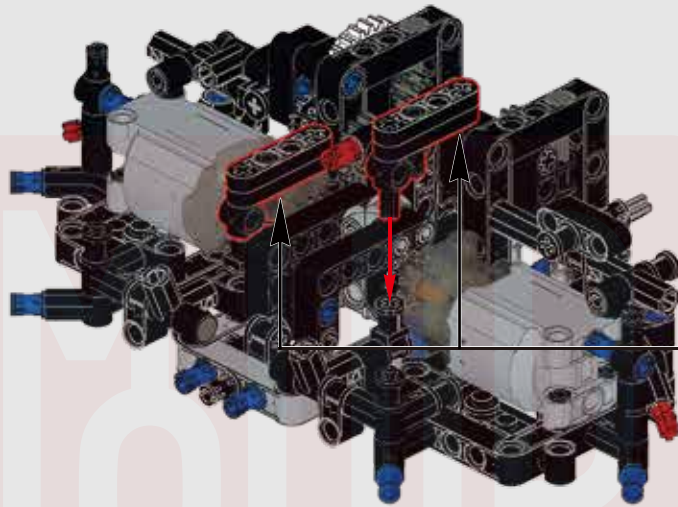

48

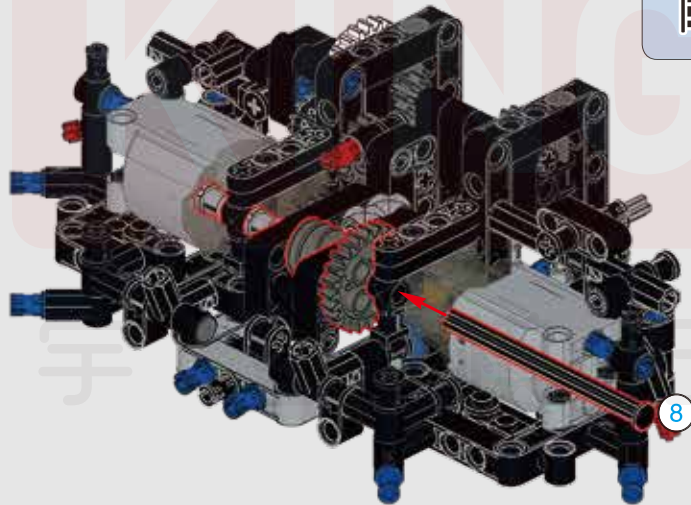

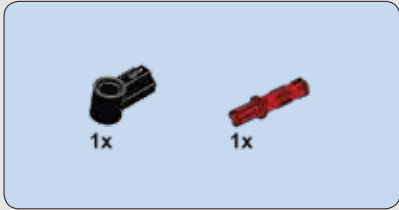

49

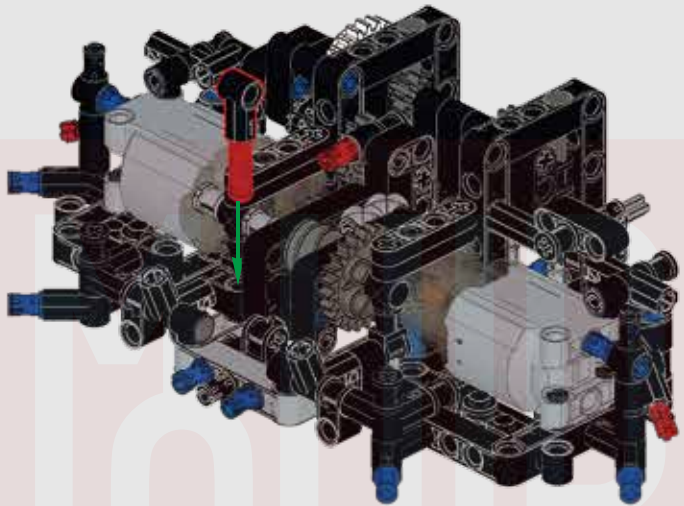

50

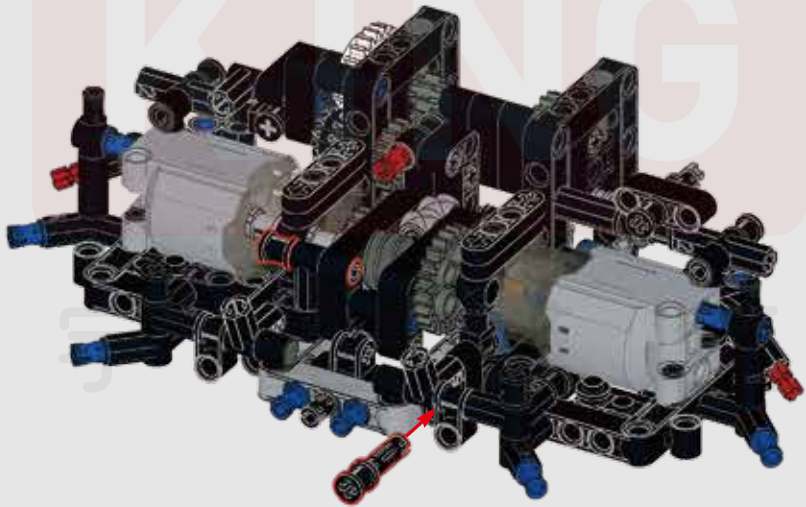

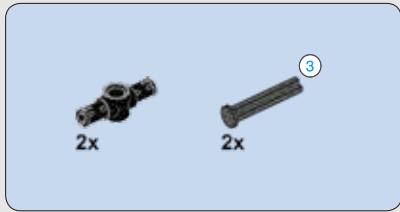

51

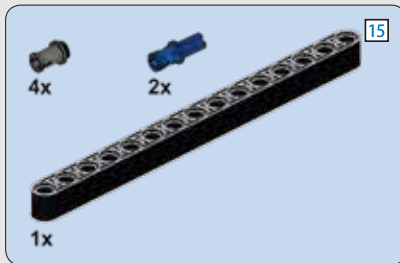
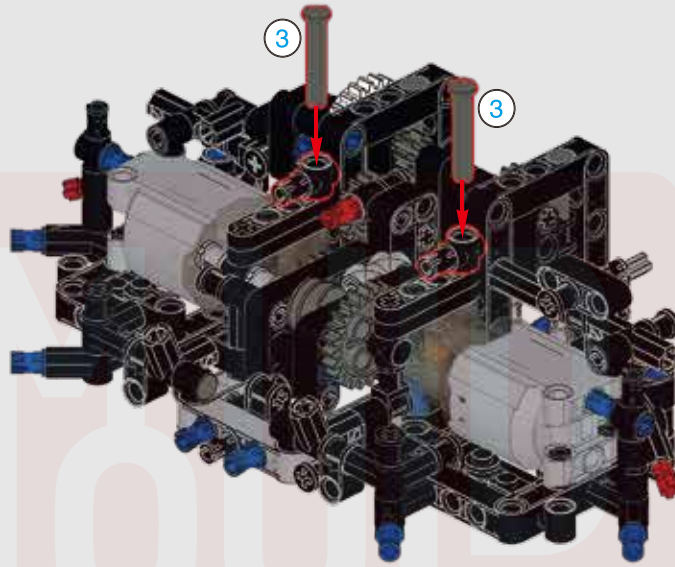

52

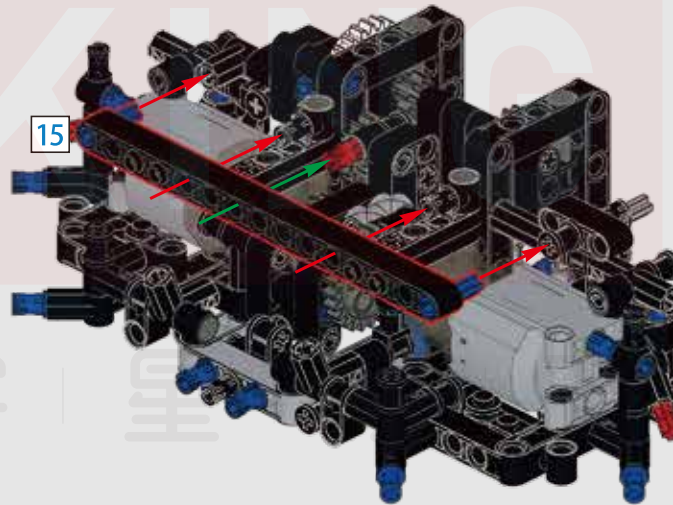

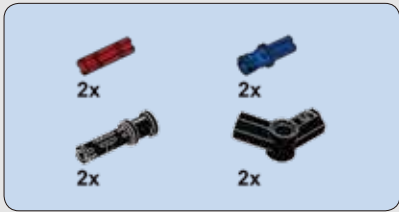

53

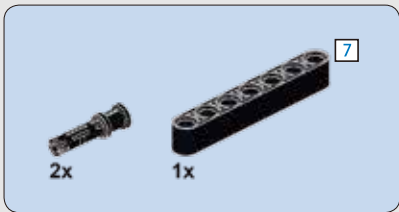
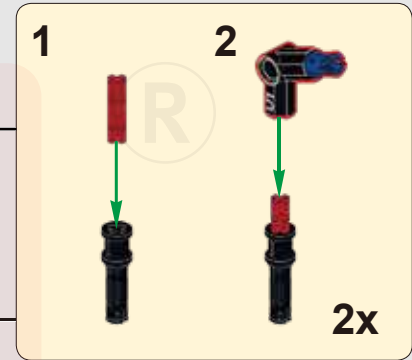
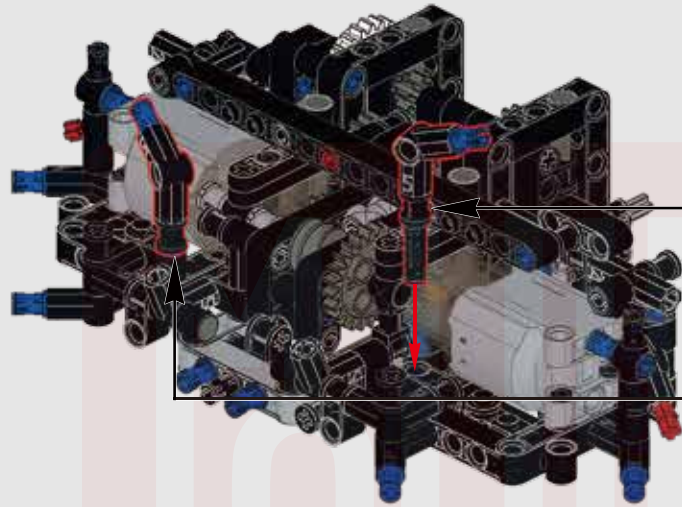
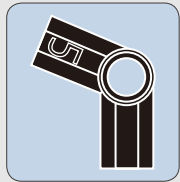

54

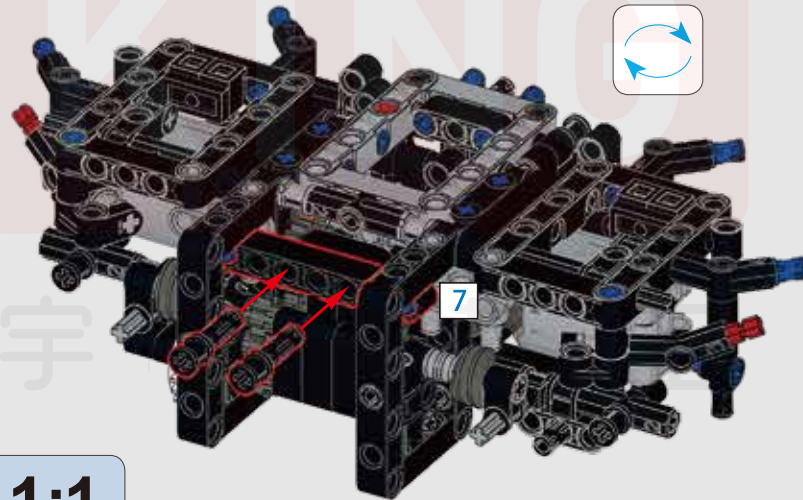

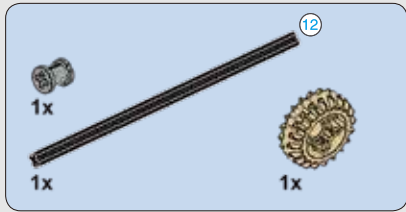

55

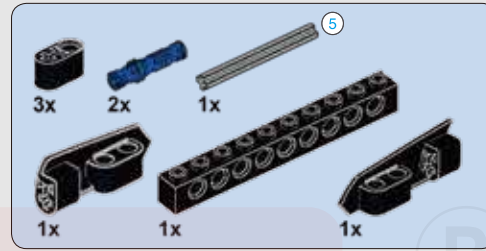
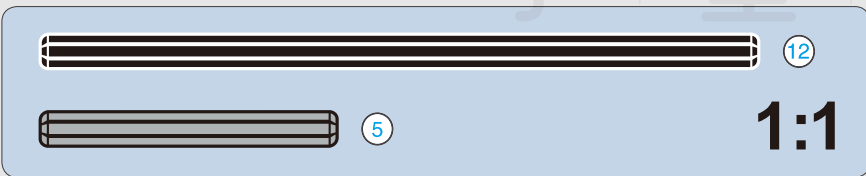
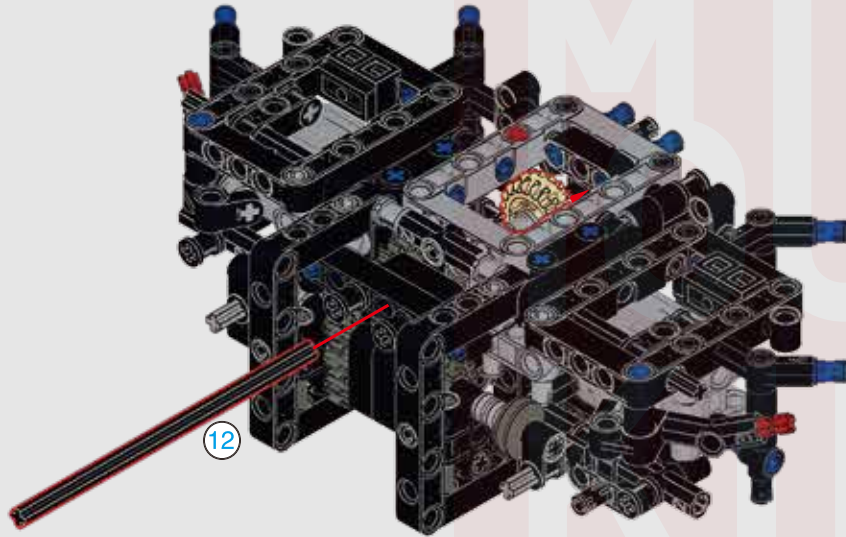

56

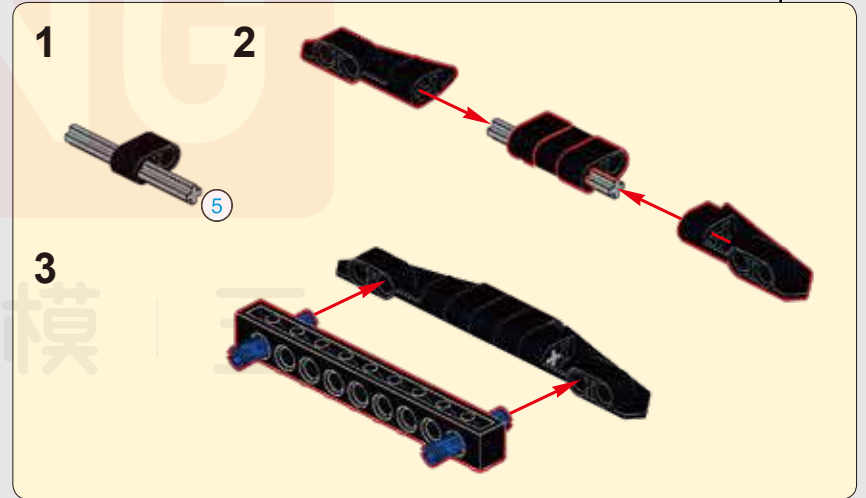
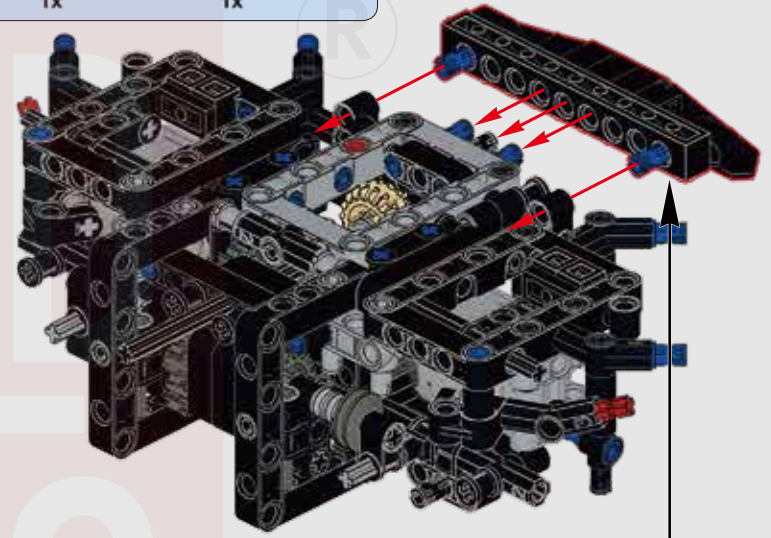

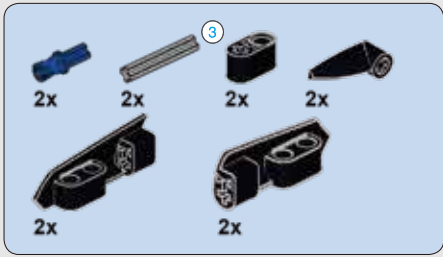

57

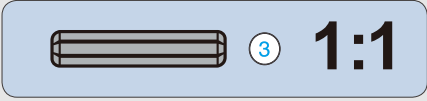
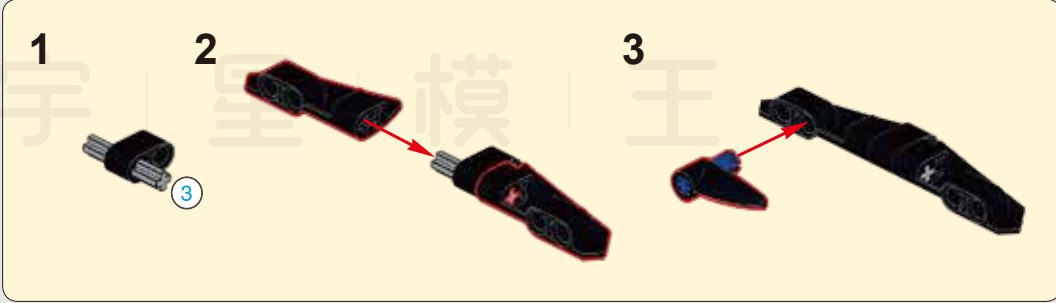
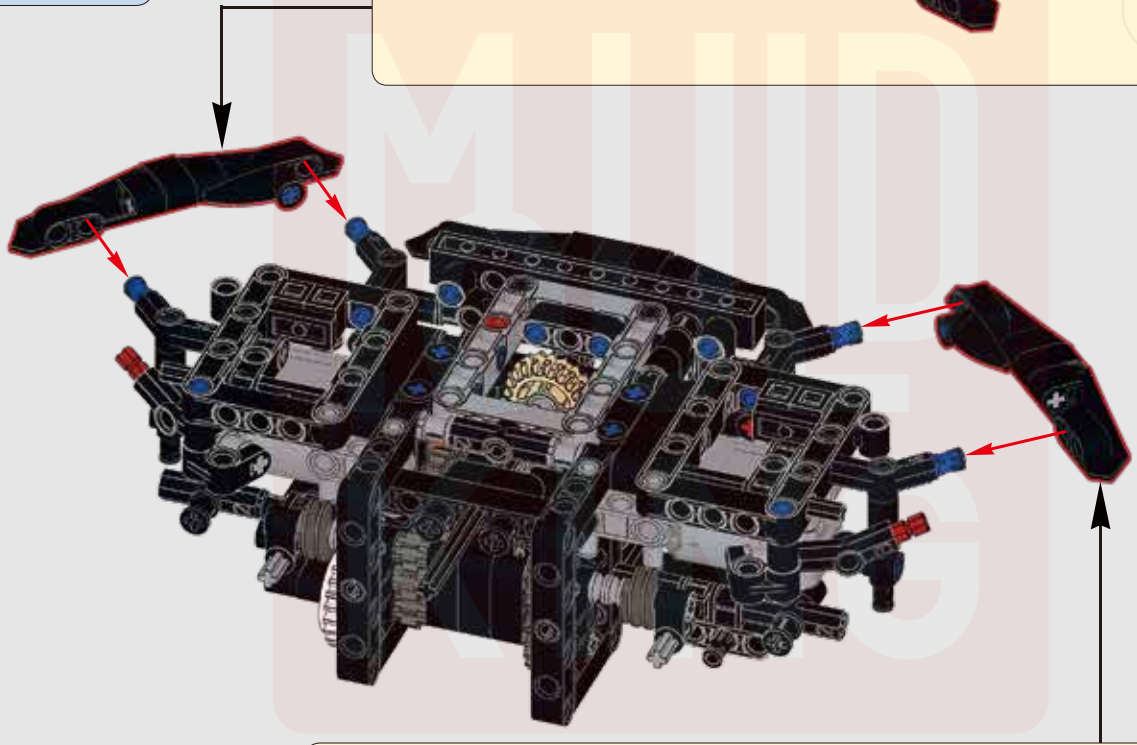
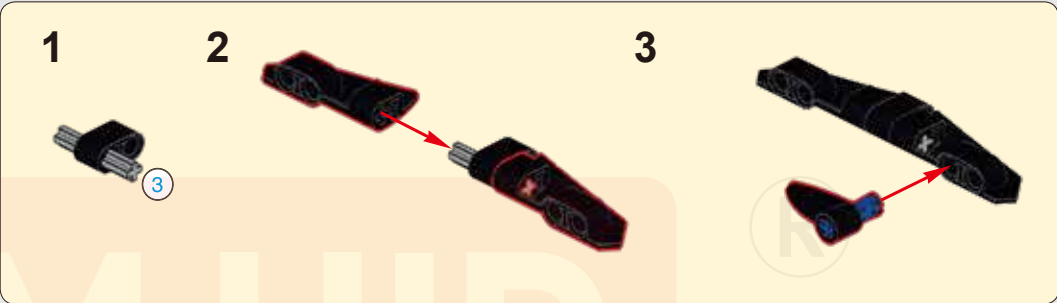

58

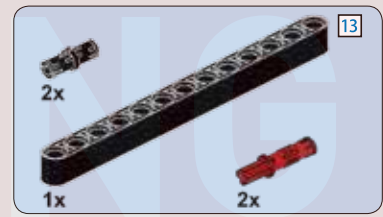
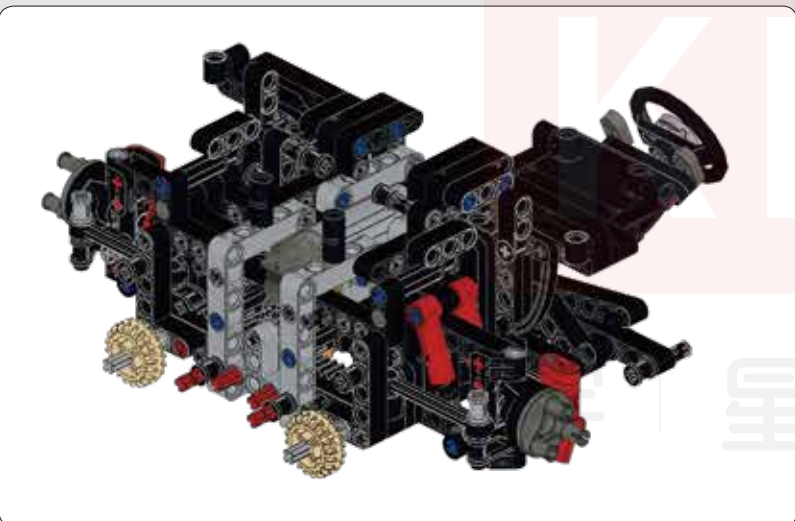
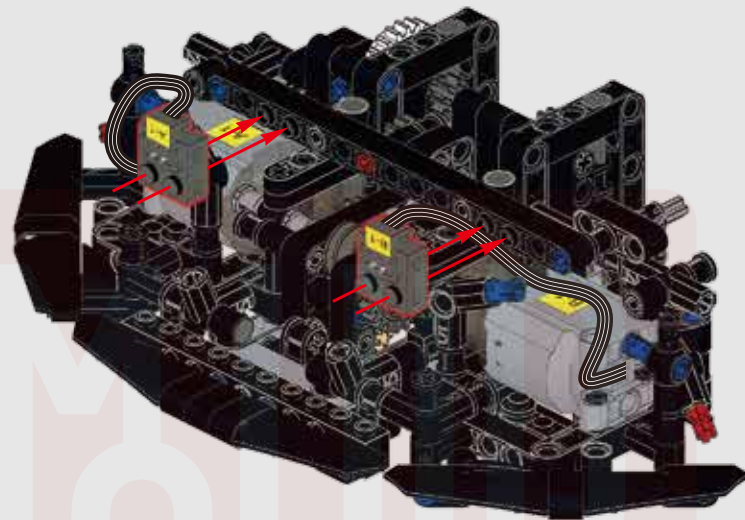

59



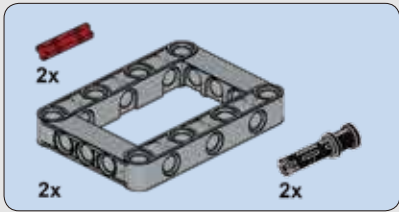

60

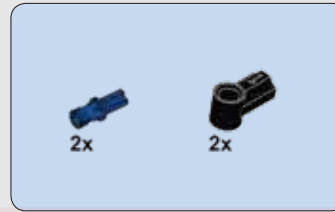
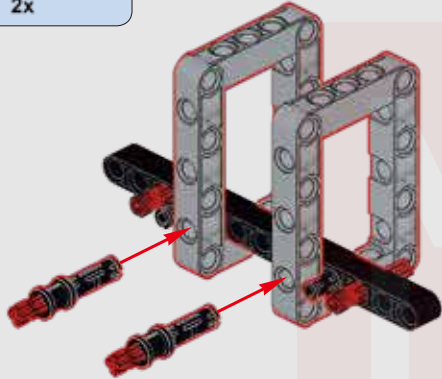

61

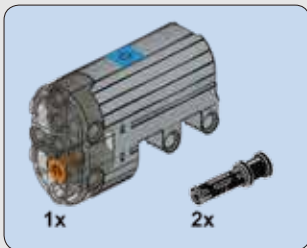
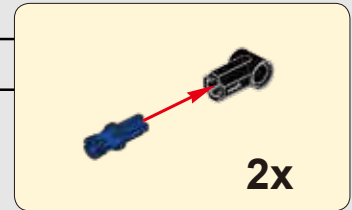
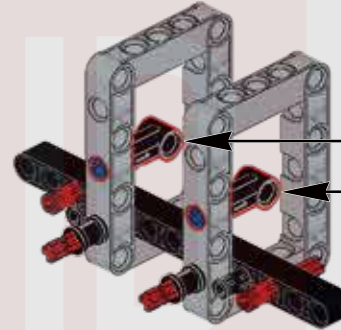

62

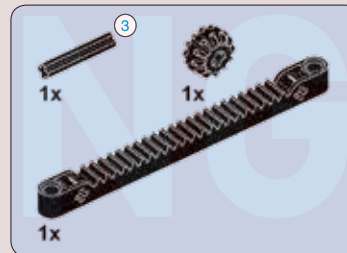
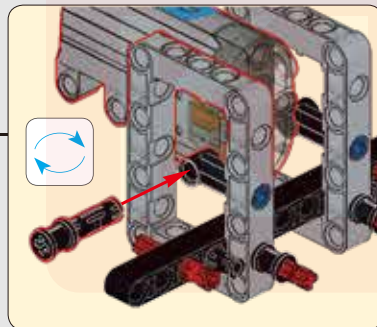
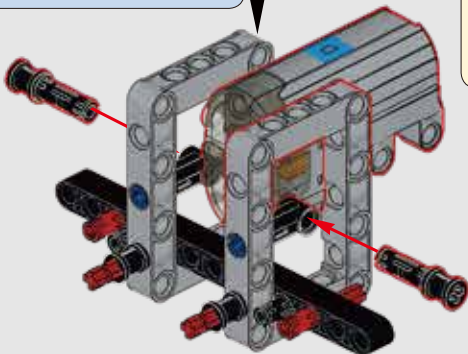

63

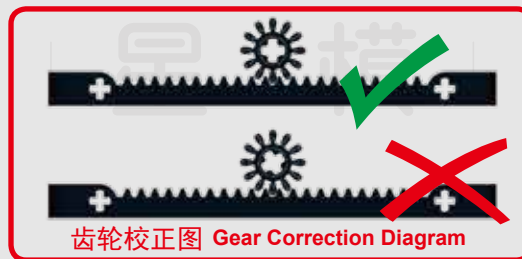

齿轮校正图 Gear Correction Diagram

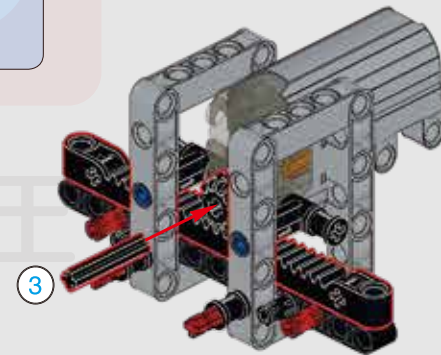

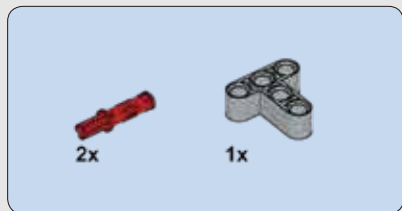

64

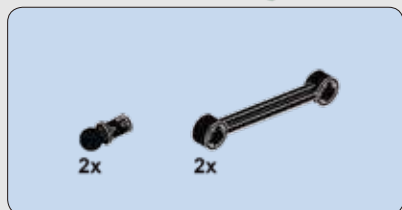
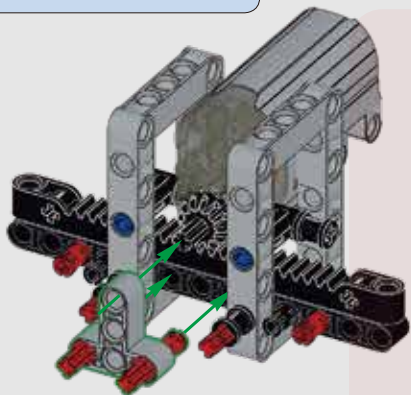

65

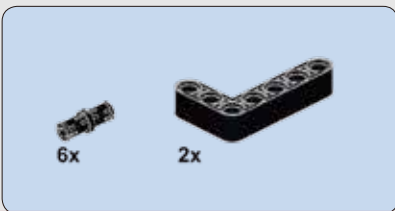
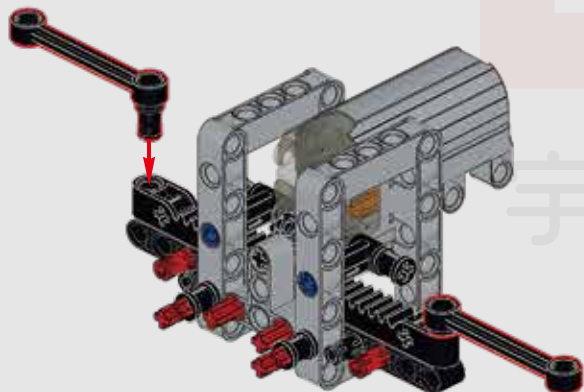

66

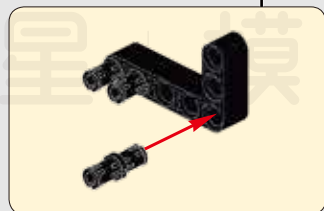
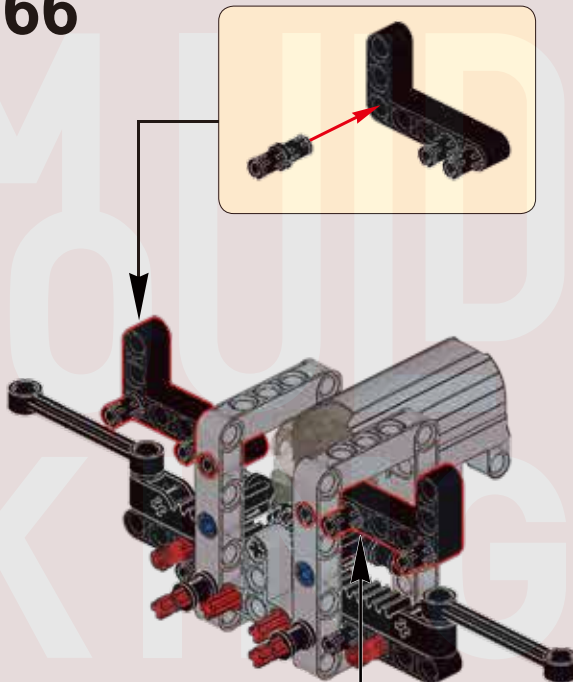

67



注意：拼装说明请参考13090 迈凯伦P1静态说明第18-20页57-66步（请忽略66-3的红色插销）

Note:Please refer to step 57-66 on page 18-20 of 13090 McLaren P1 Manual Version for assembly instructions. (Please ignore the red bolt of 66-3)

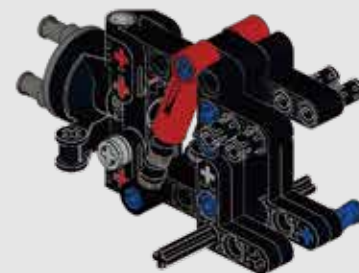

注意：拼装说明请参考13090 迈凯伦P1静态说明第20-22页67-76步（请忽略76-3的红色插销）

Note:Please refer to step 67-76 on page 20-22 of 13090 McLaren P1 Manual Version for assembly instructions. (Please ignore the red bolt of 76-3)

68

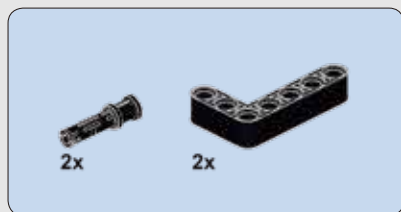
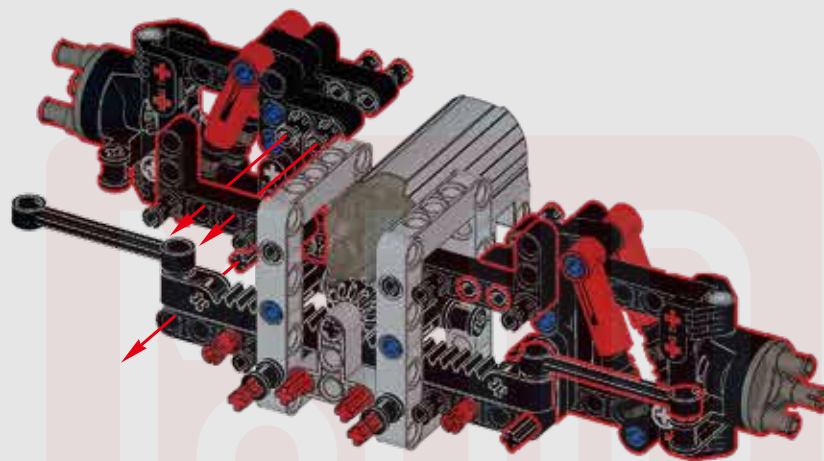

69

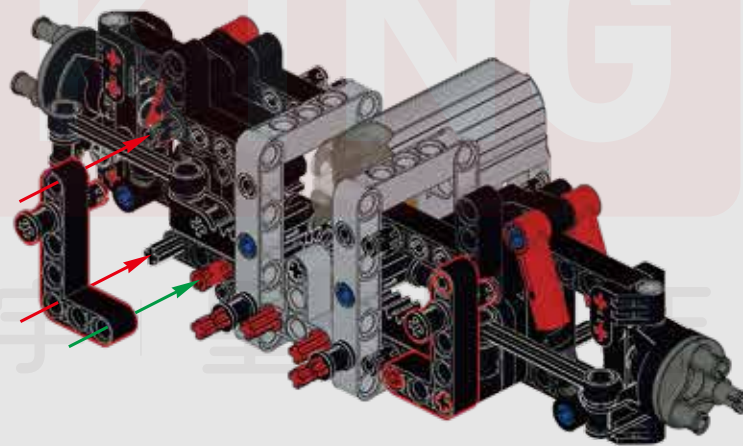

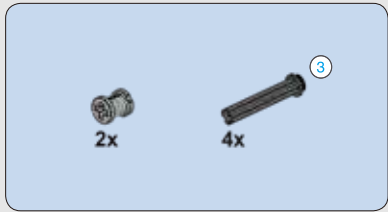

70

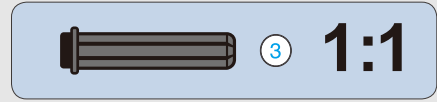
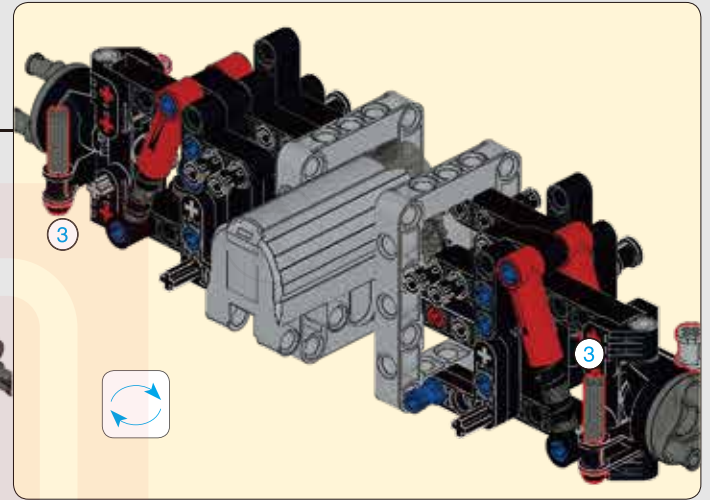
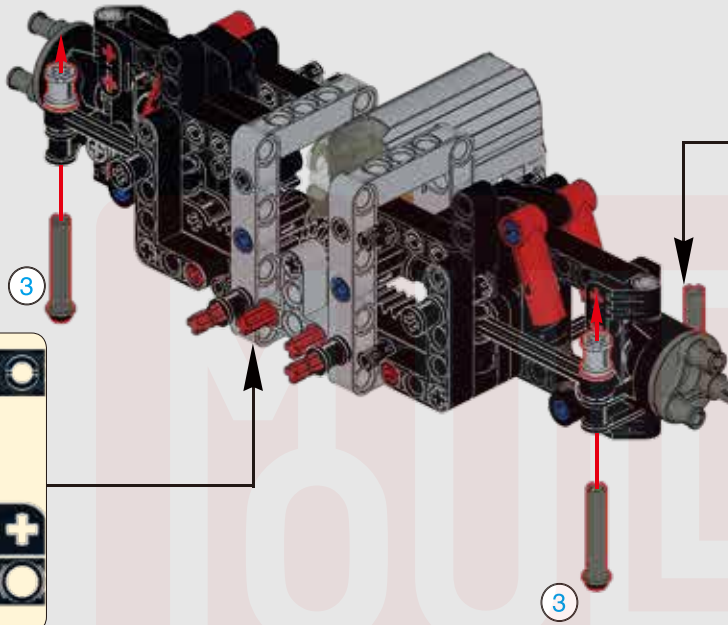
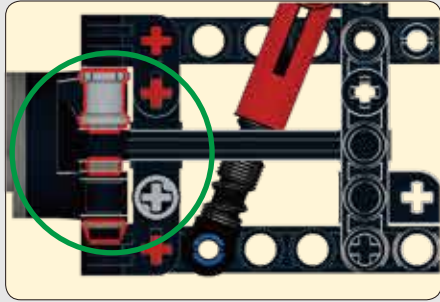

71

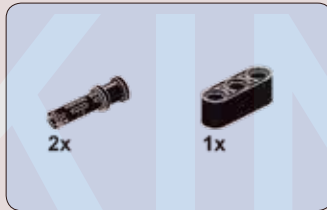
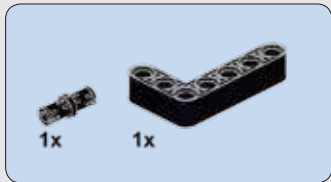

72



73

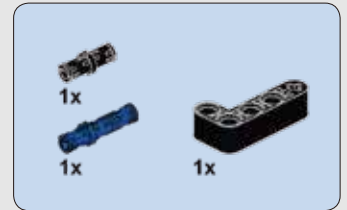

74



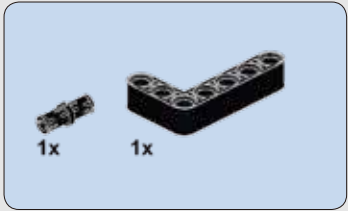
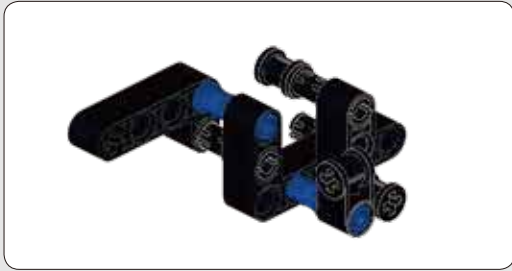

75

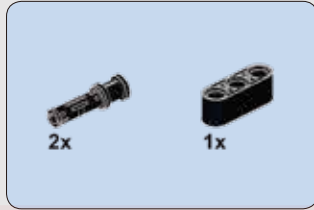

76



77

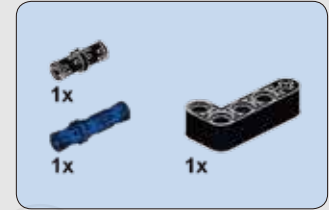

78



79

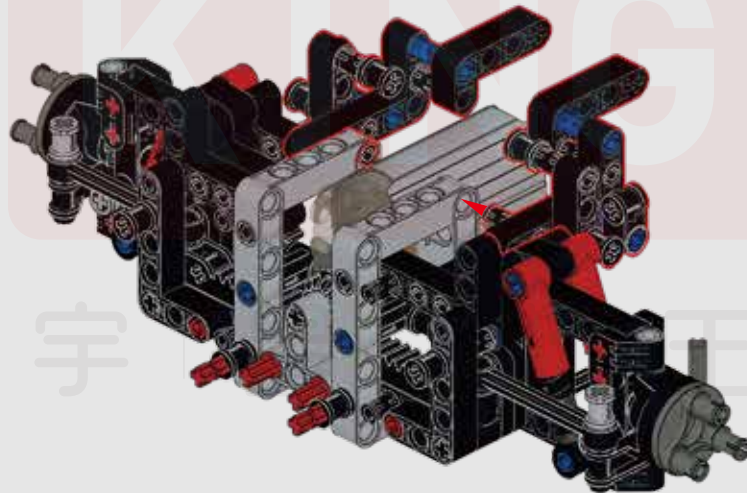

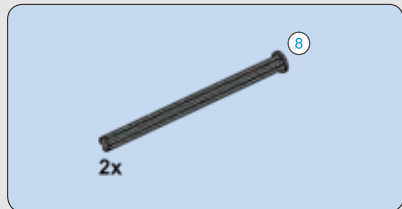

80

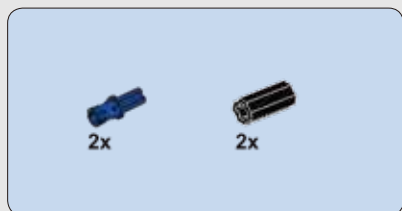
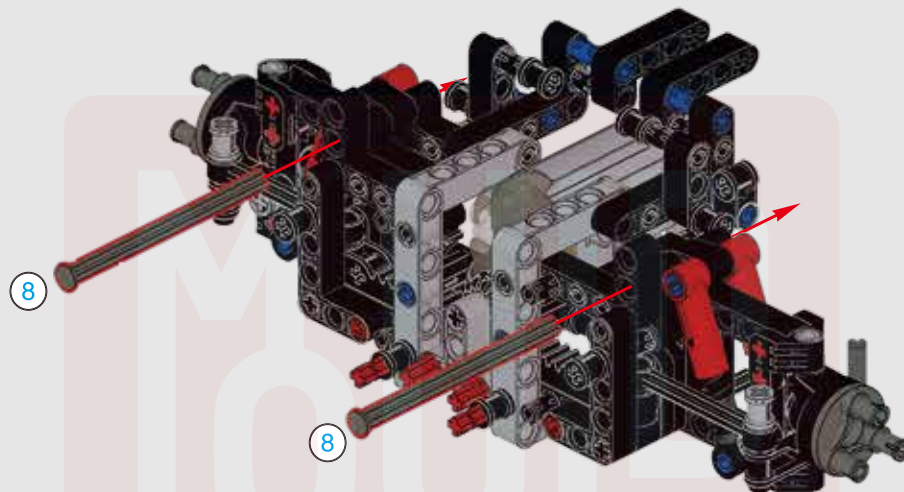
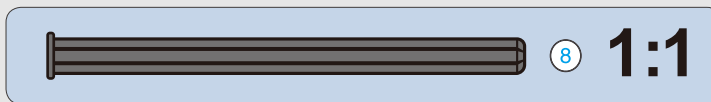

81

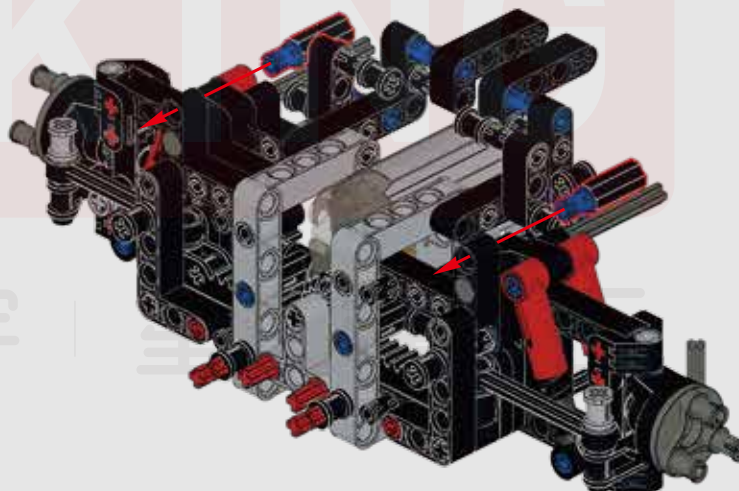

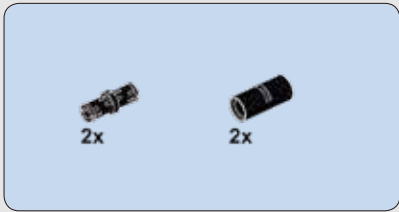

82

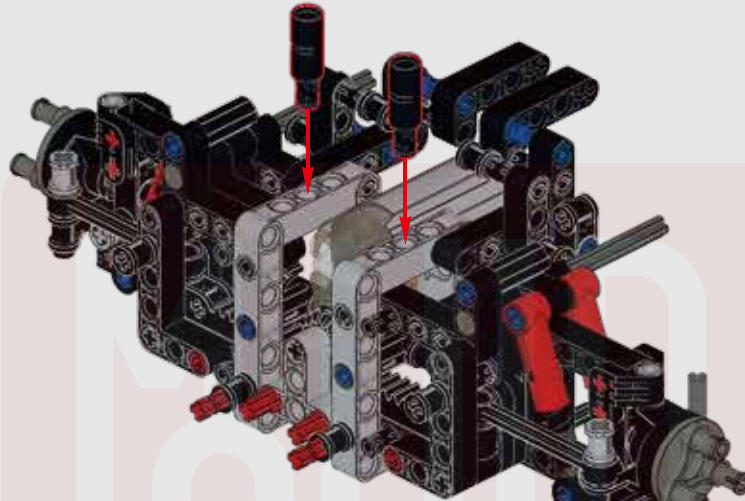

83

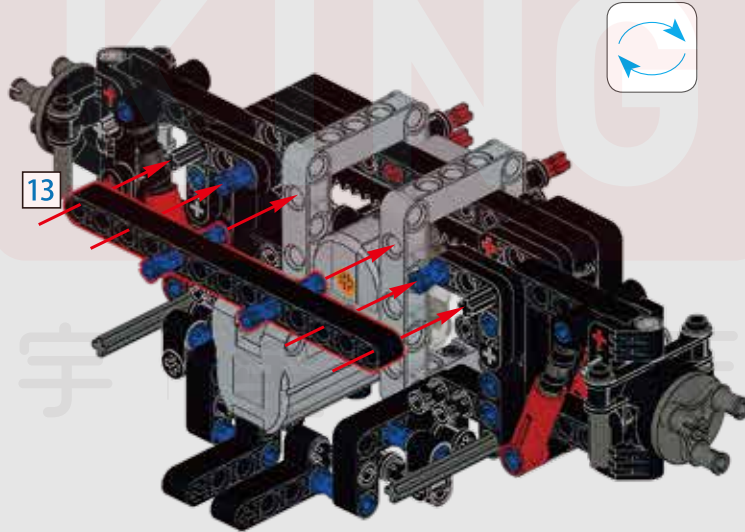

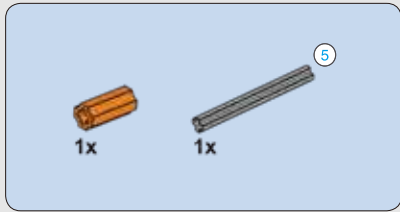

84

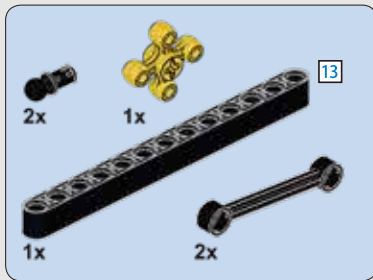
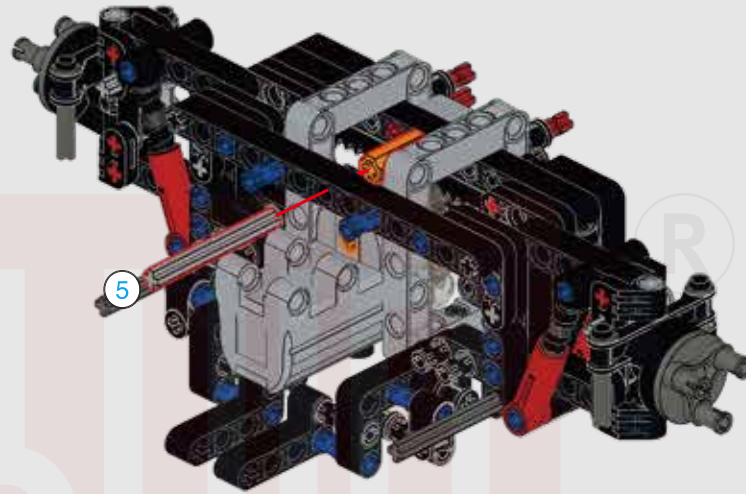

85

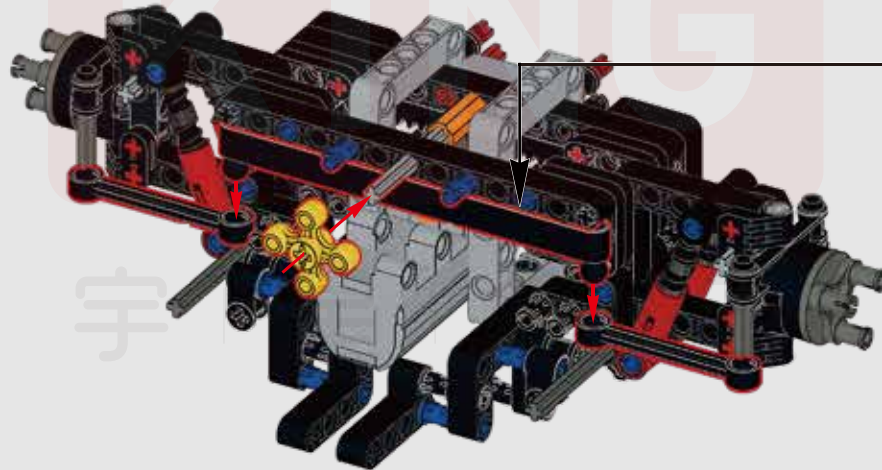



86

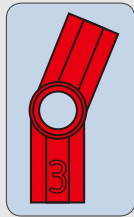
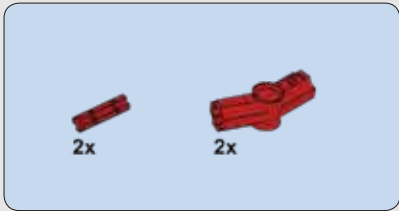
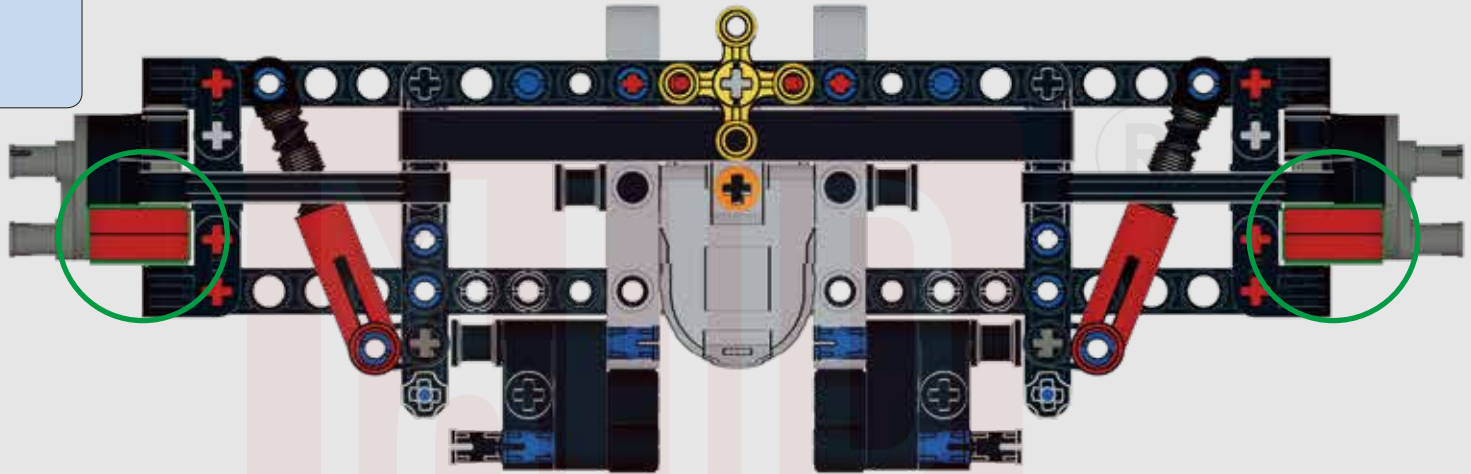

87

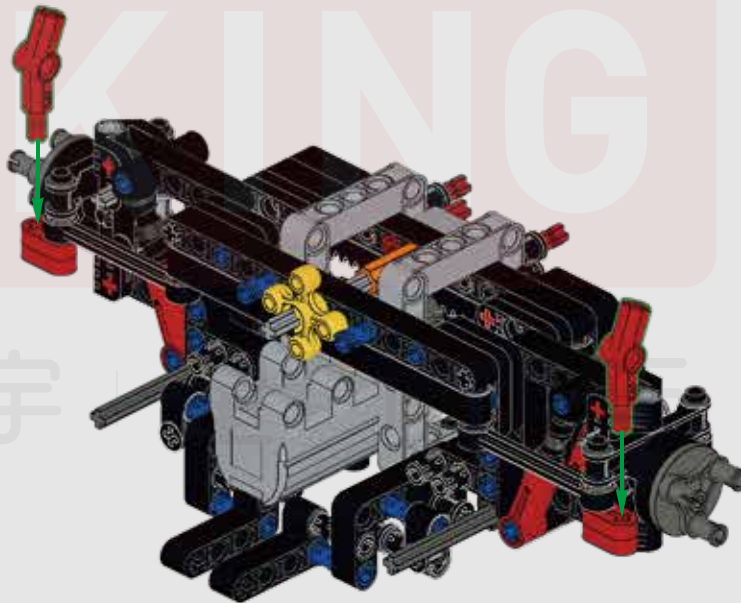

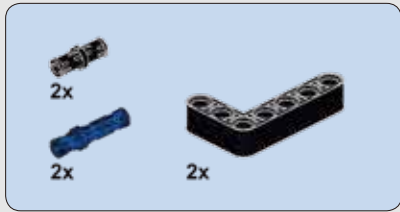

88

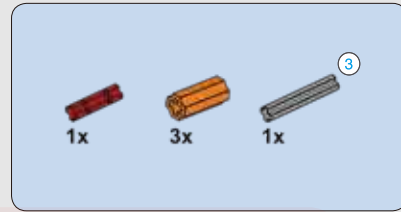
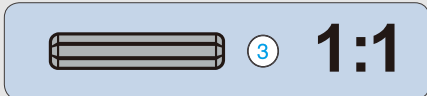
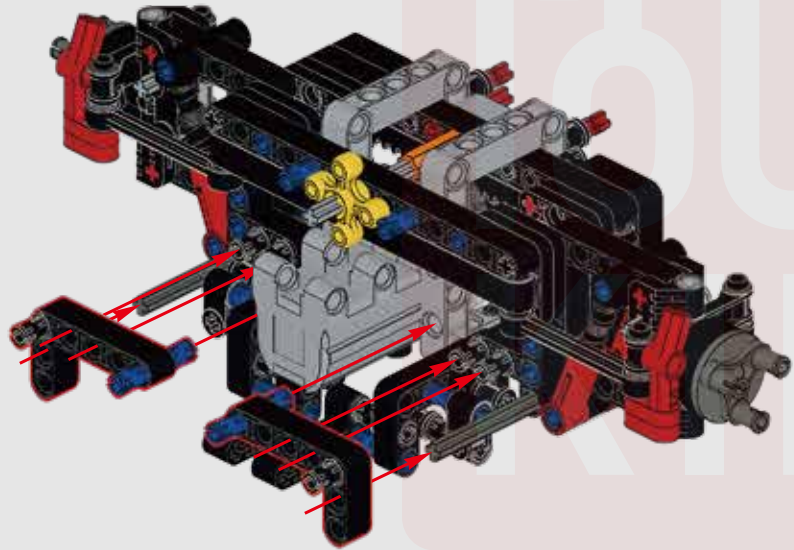

89

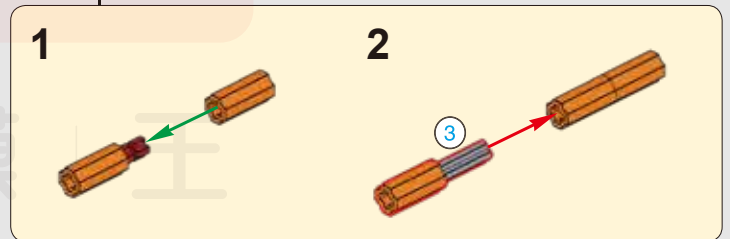
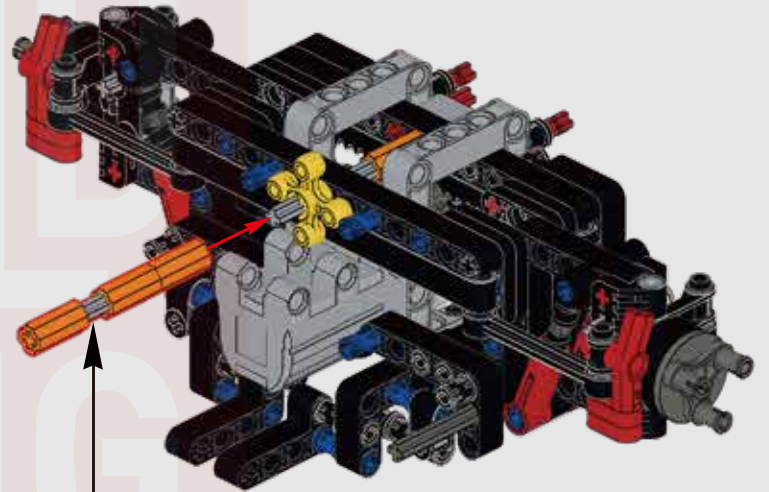

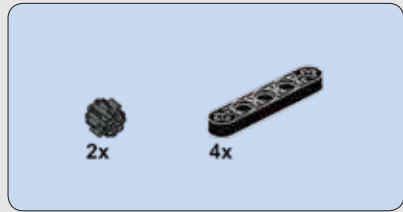

90

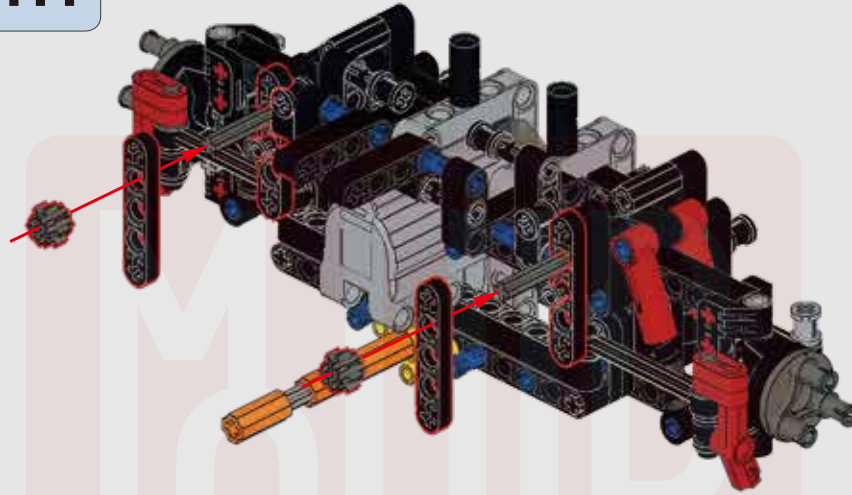
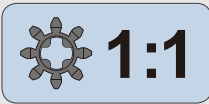

91

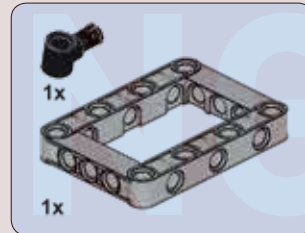

92

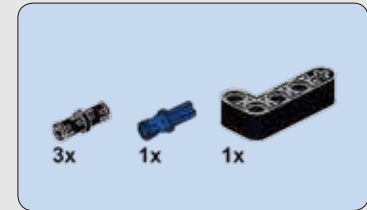
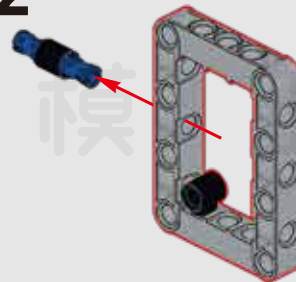

93

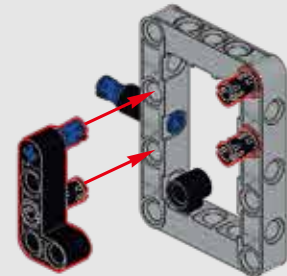

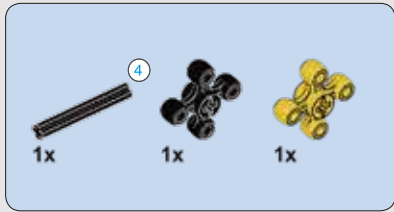

94

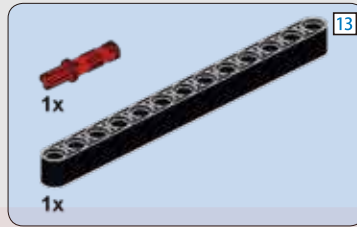
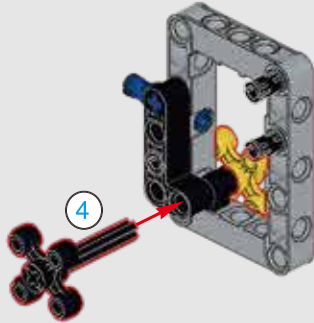

95

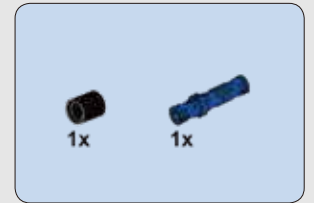
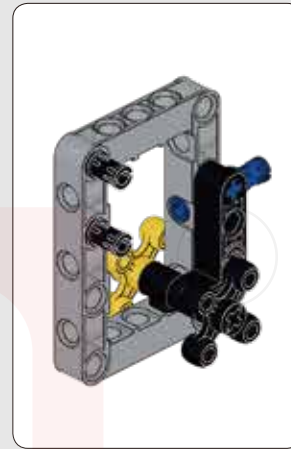
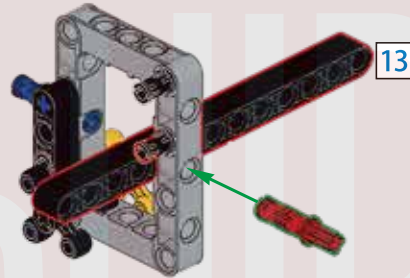

96

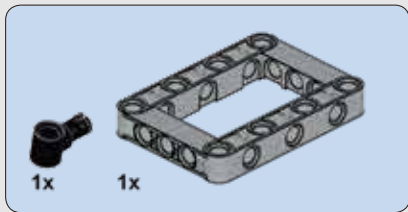
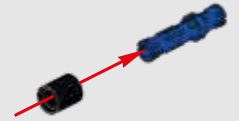

97

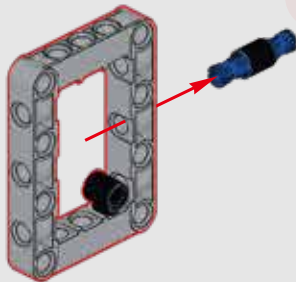

98

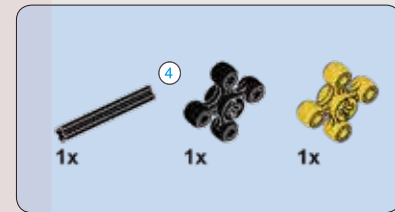
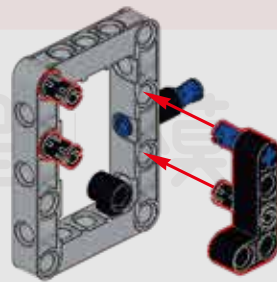

99

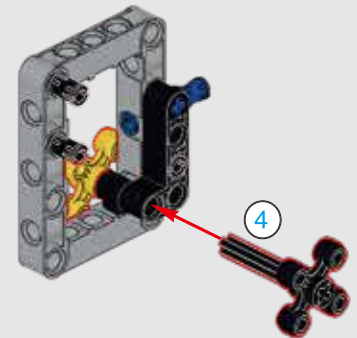



100

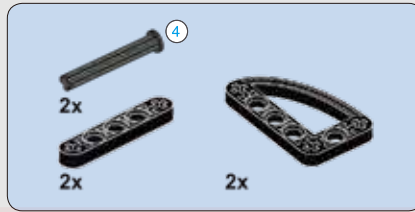
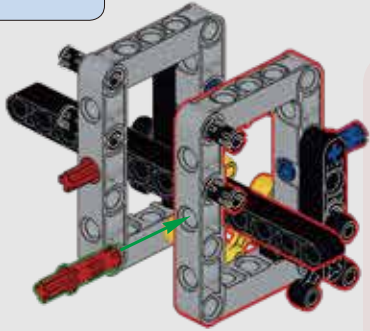

101

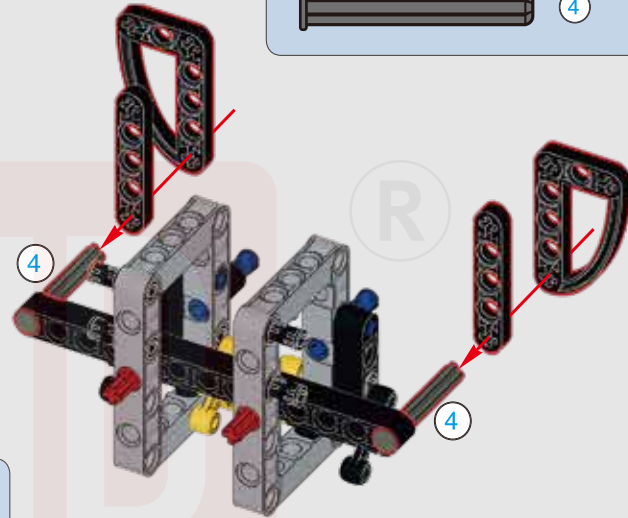

102

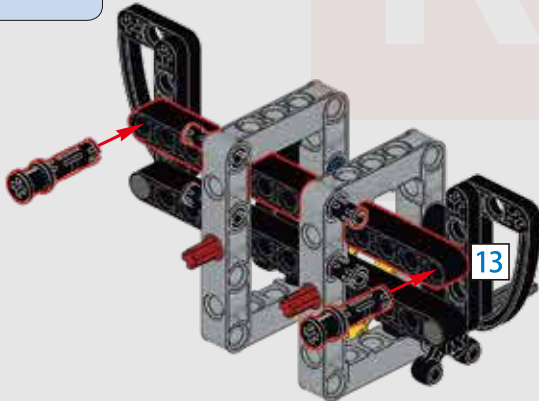

103

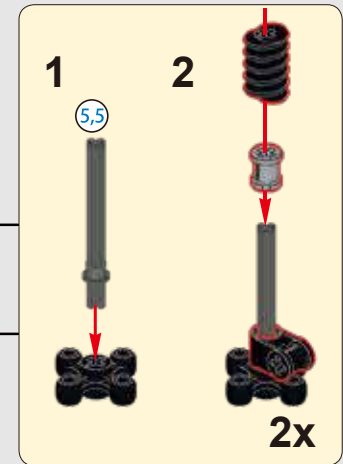
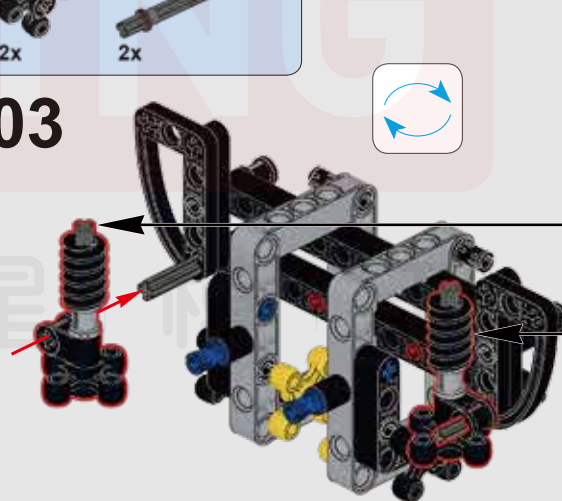
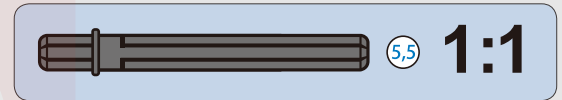

104

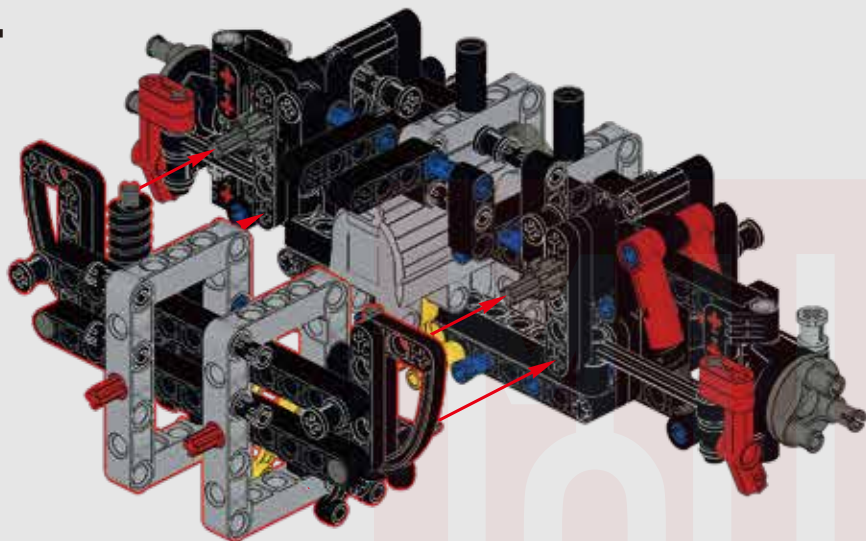

底盘水平校准 Chassis horizontal calibration

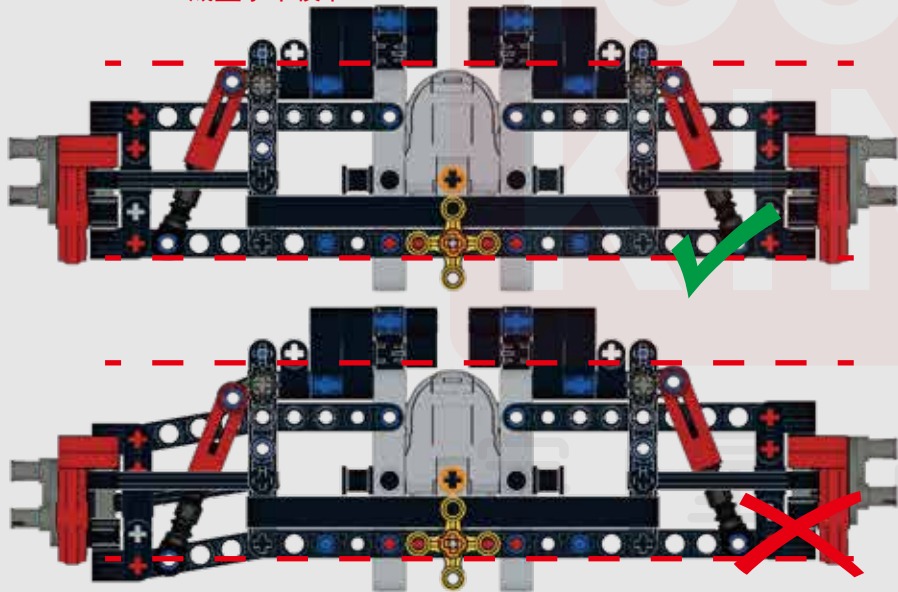

105

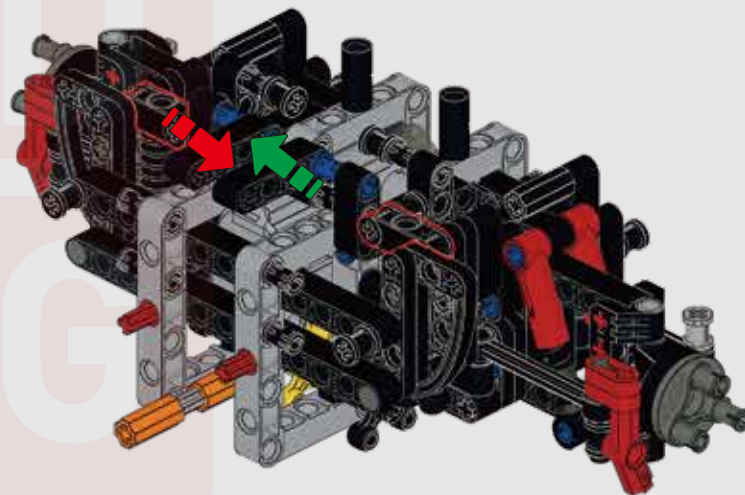

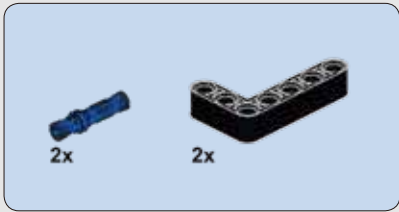

106

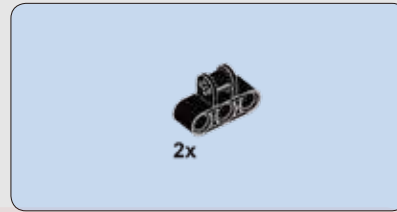
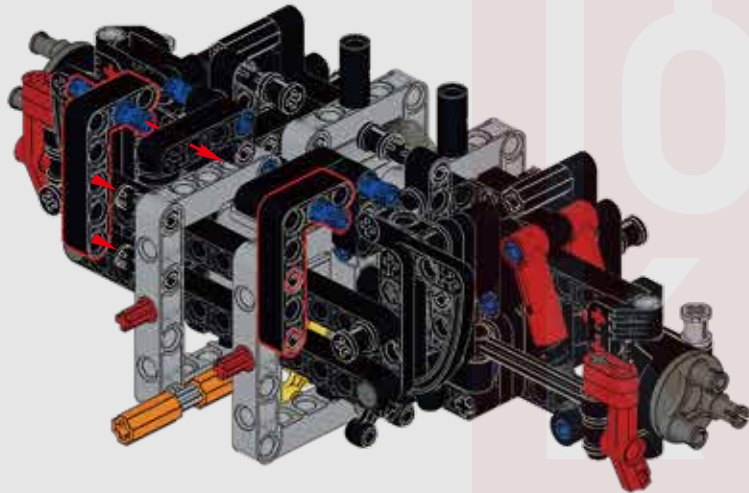

107

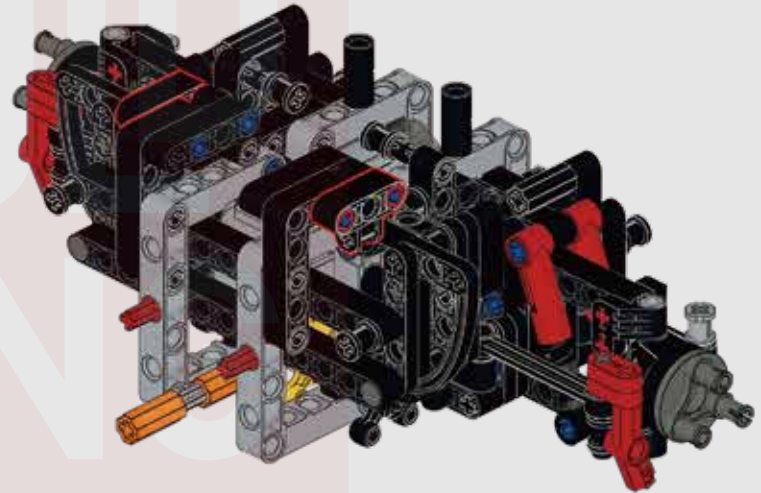

宇 | 星 | 模 | 王

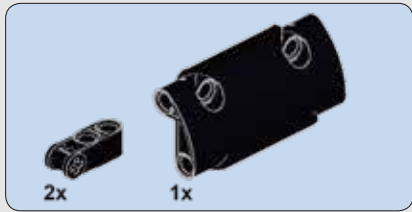

110

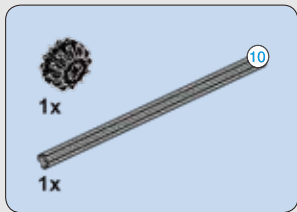
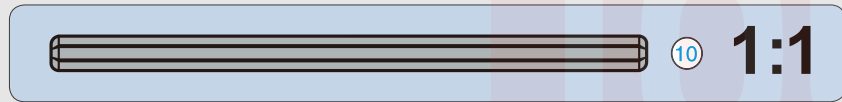
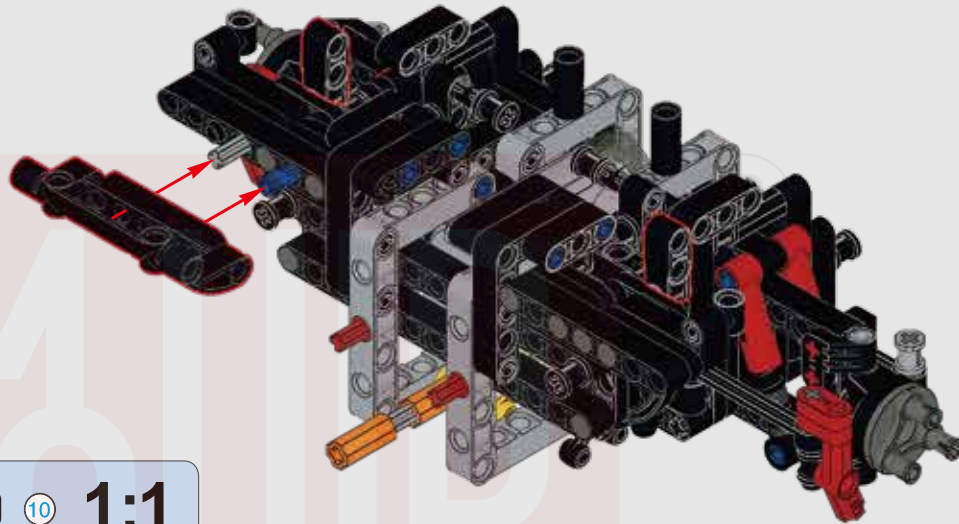

111

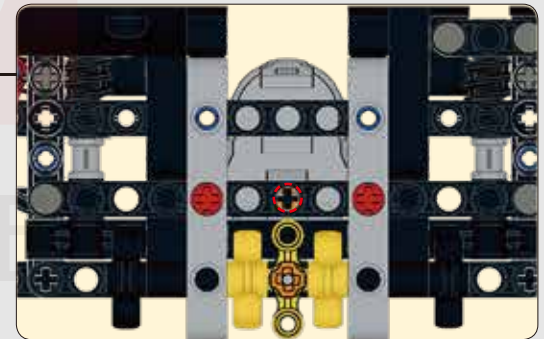
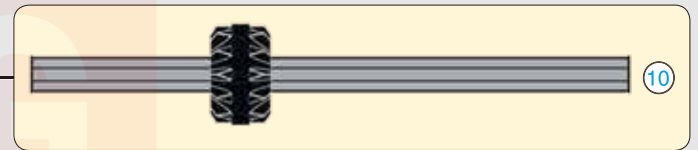
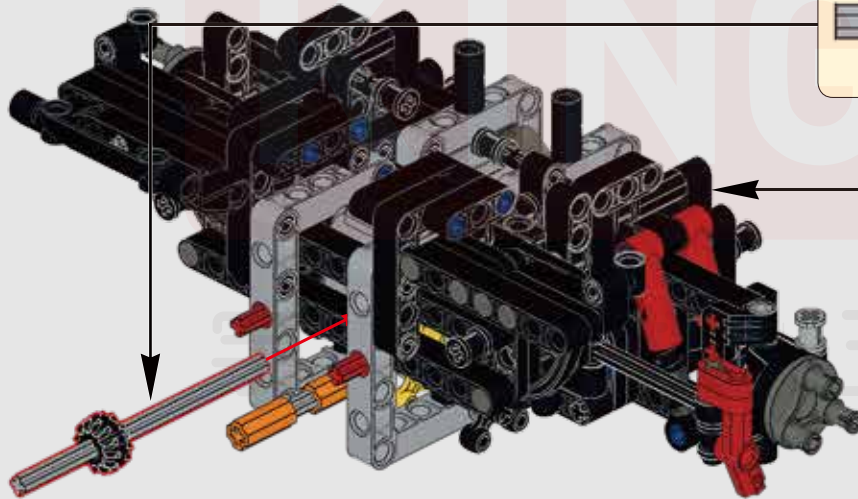

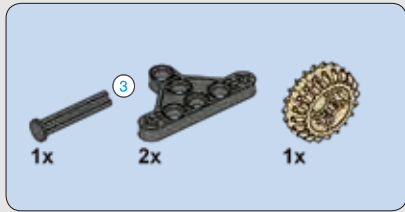

112

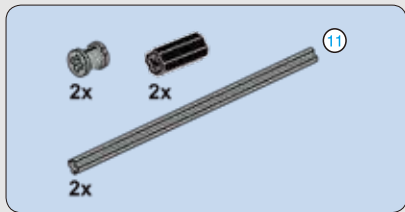
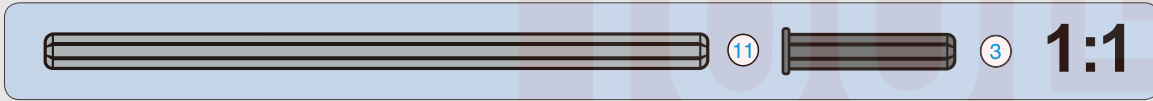
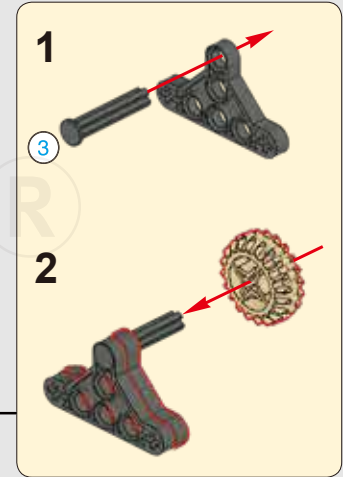
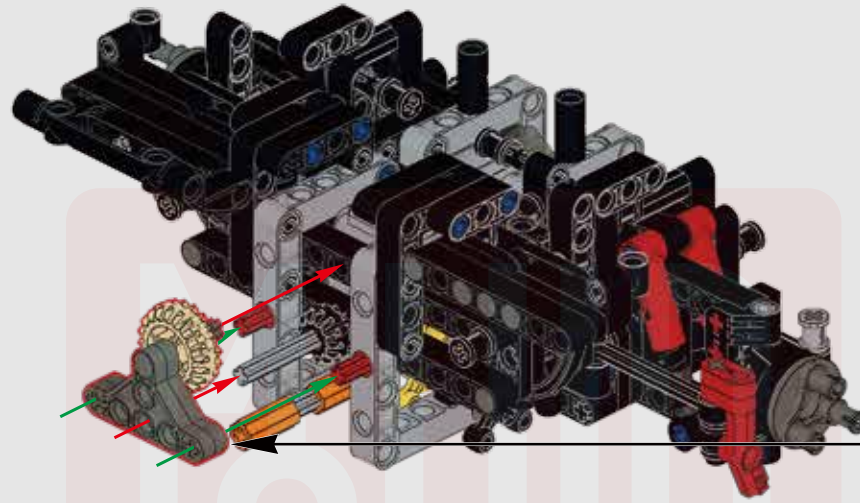

113

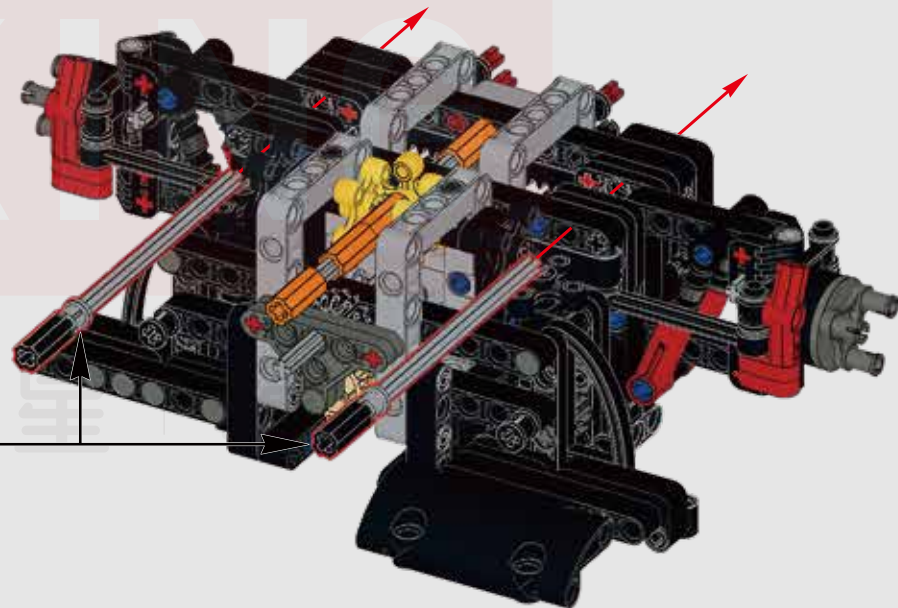
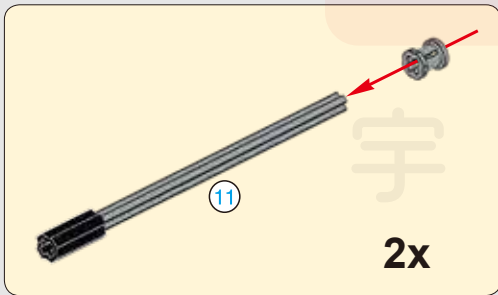



114

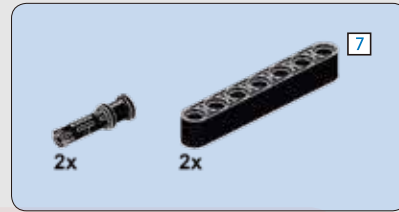
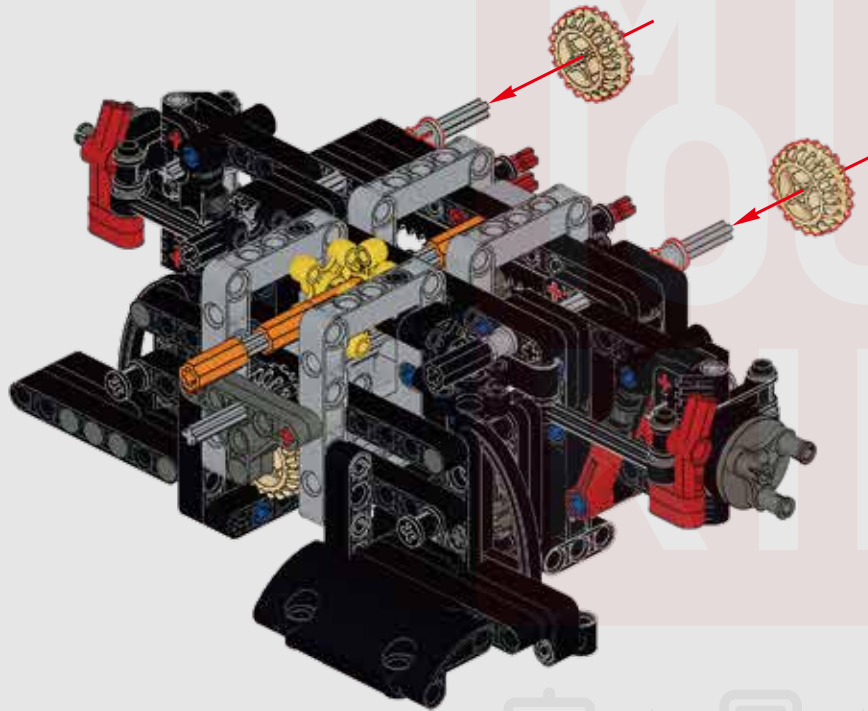

115

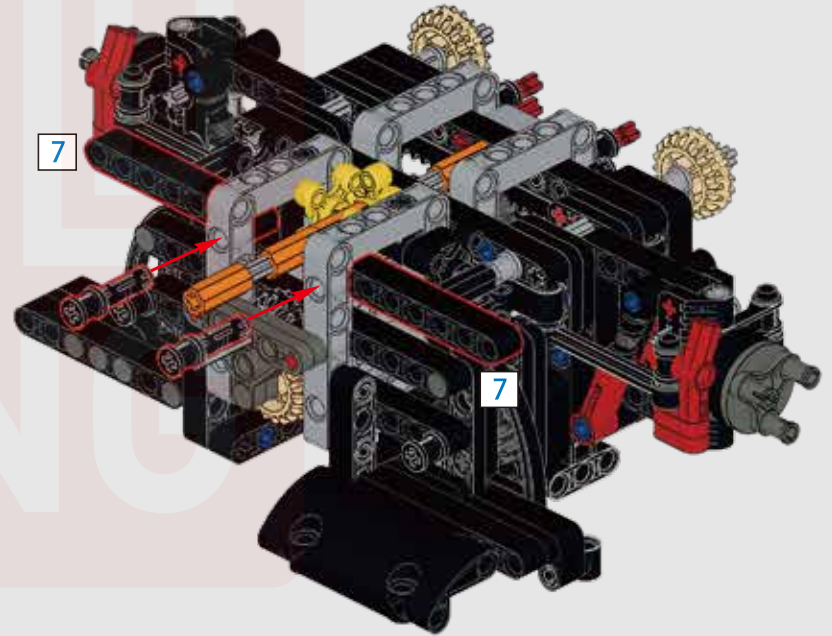

宇 | 星 | 模 | 王



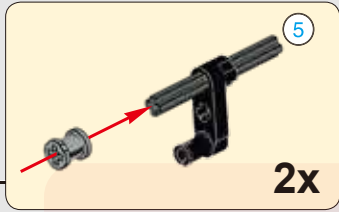
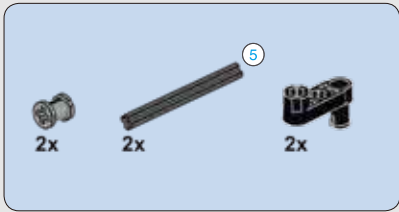

116

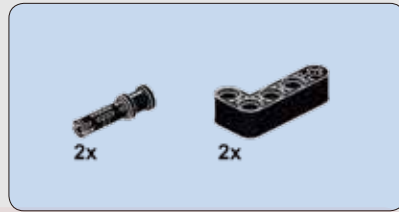
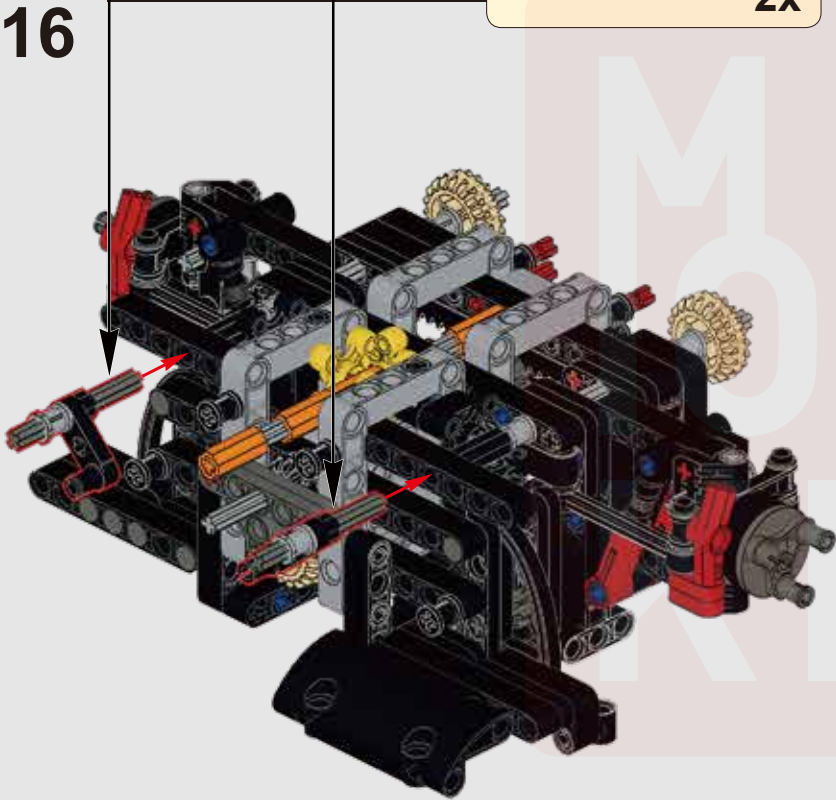

117

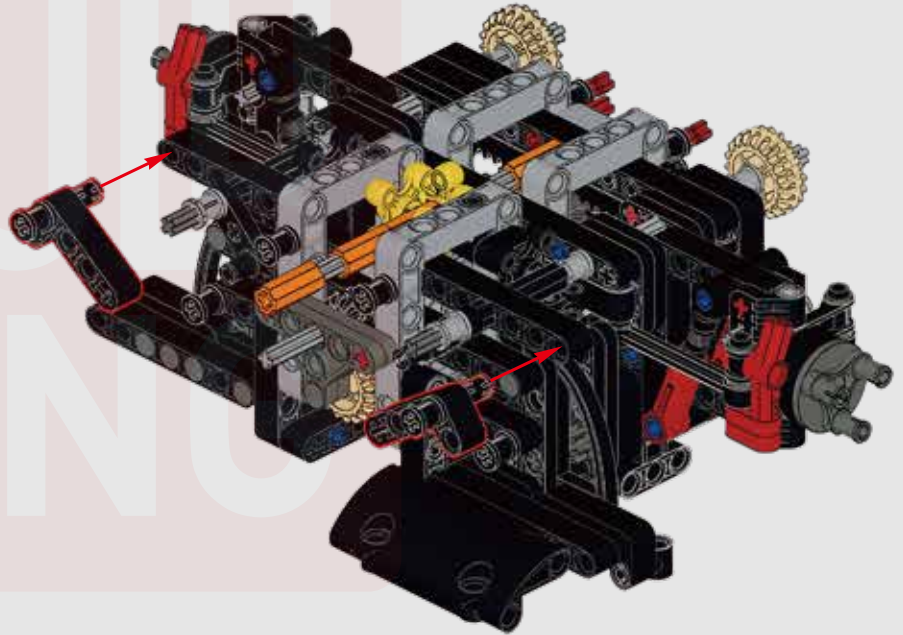

宇 | 星 | 模 | 王

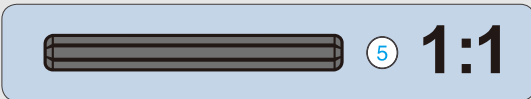



118

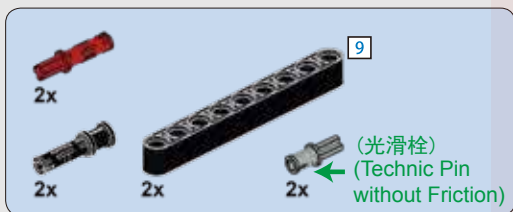
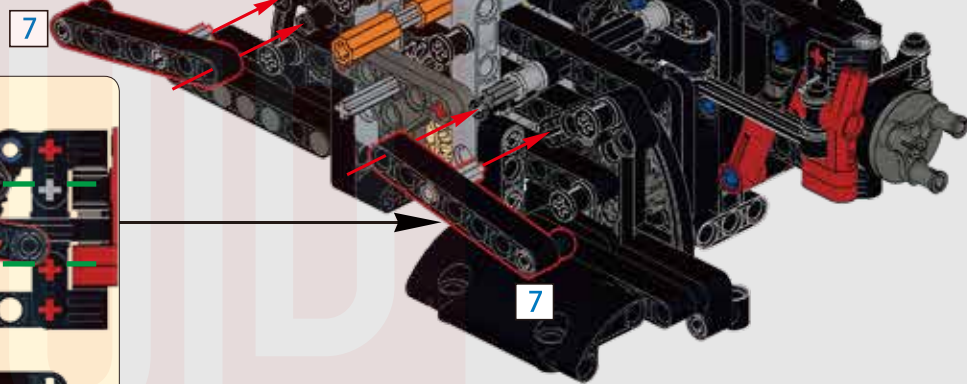
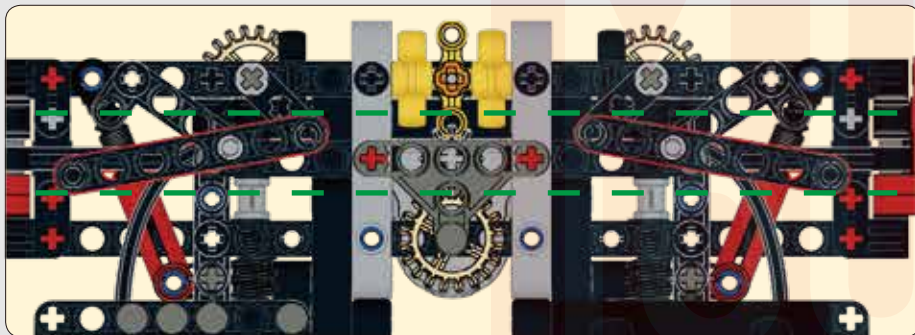

119

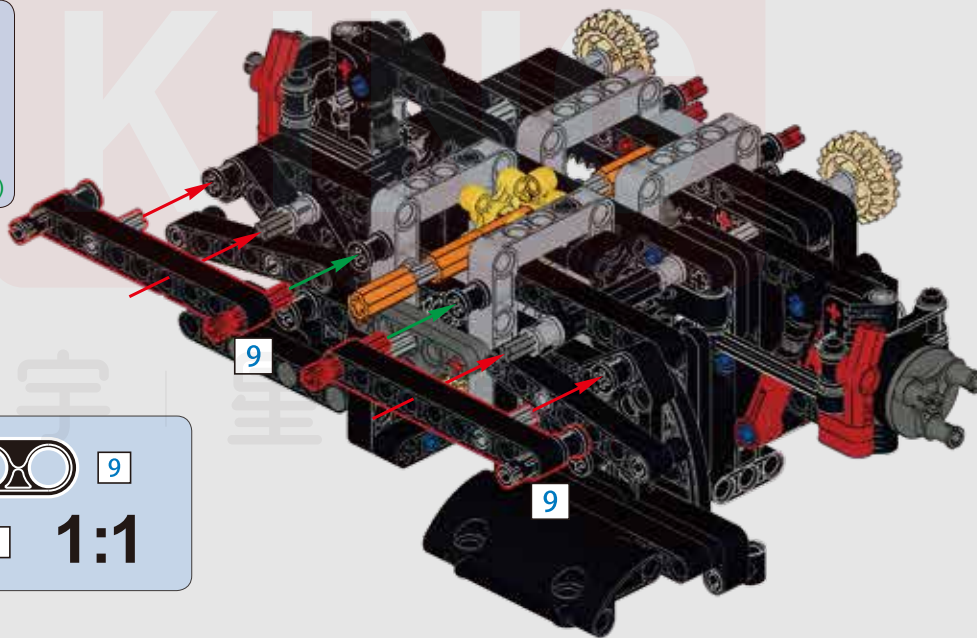
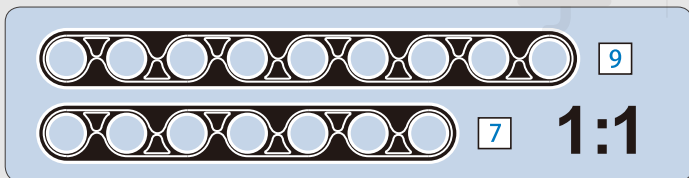

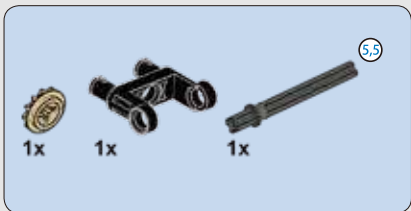

120

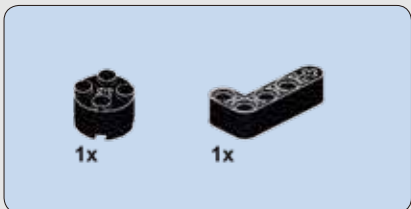

121

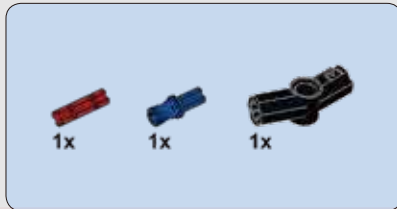
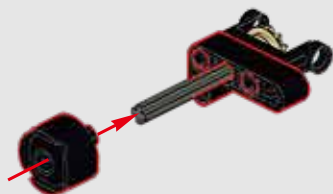

122

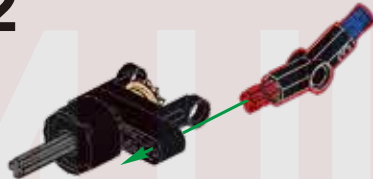

123

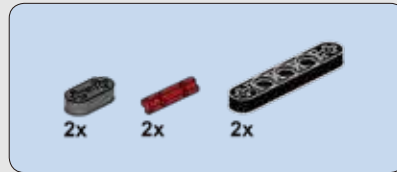
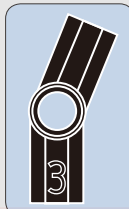
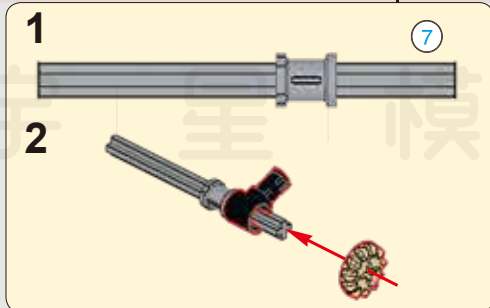
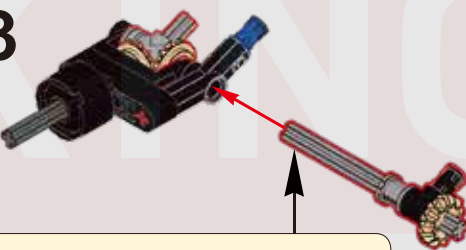

124

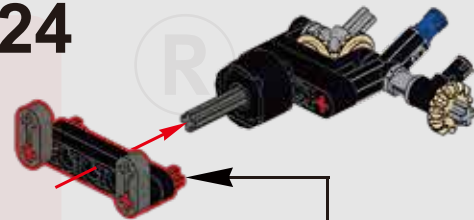

125

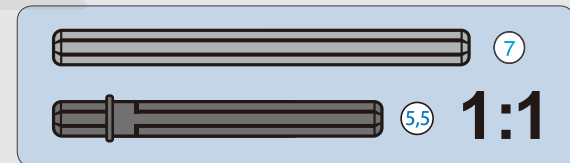

126

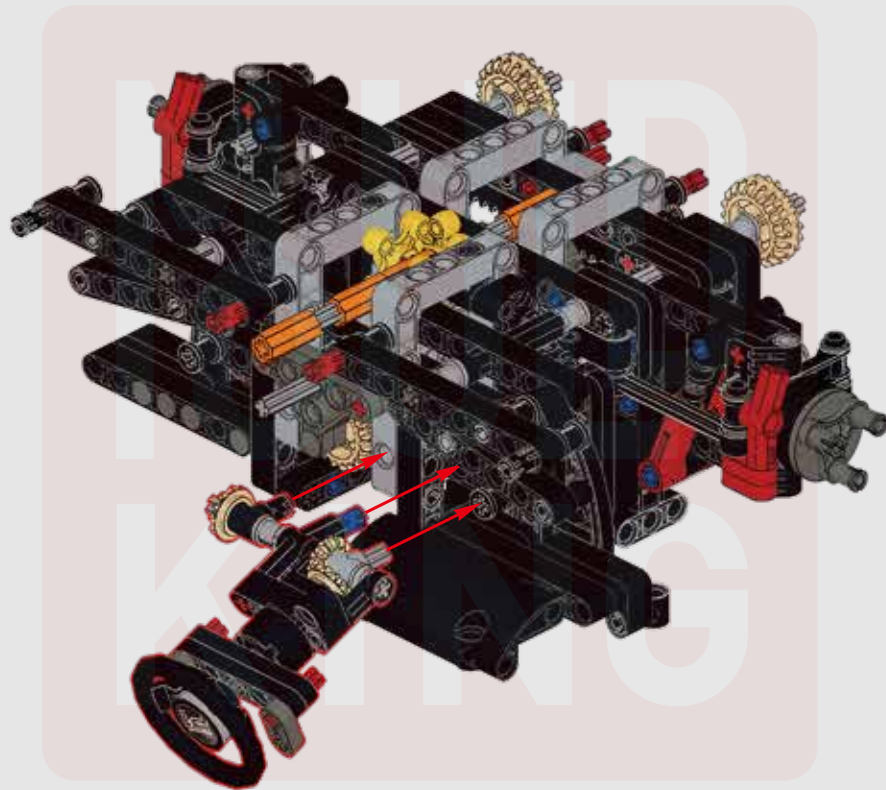

宇 | 星 | 模 | 王

127

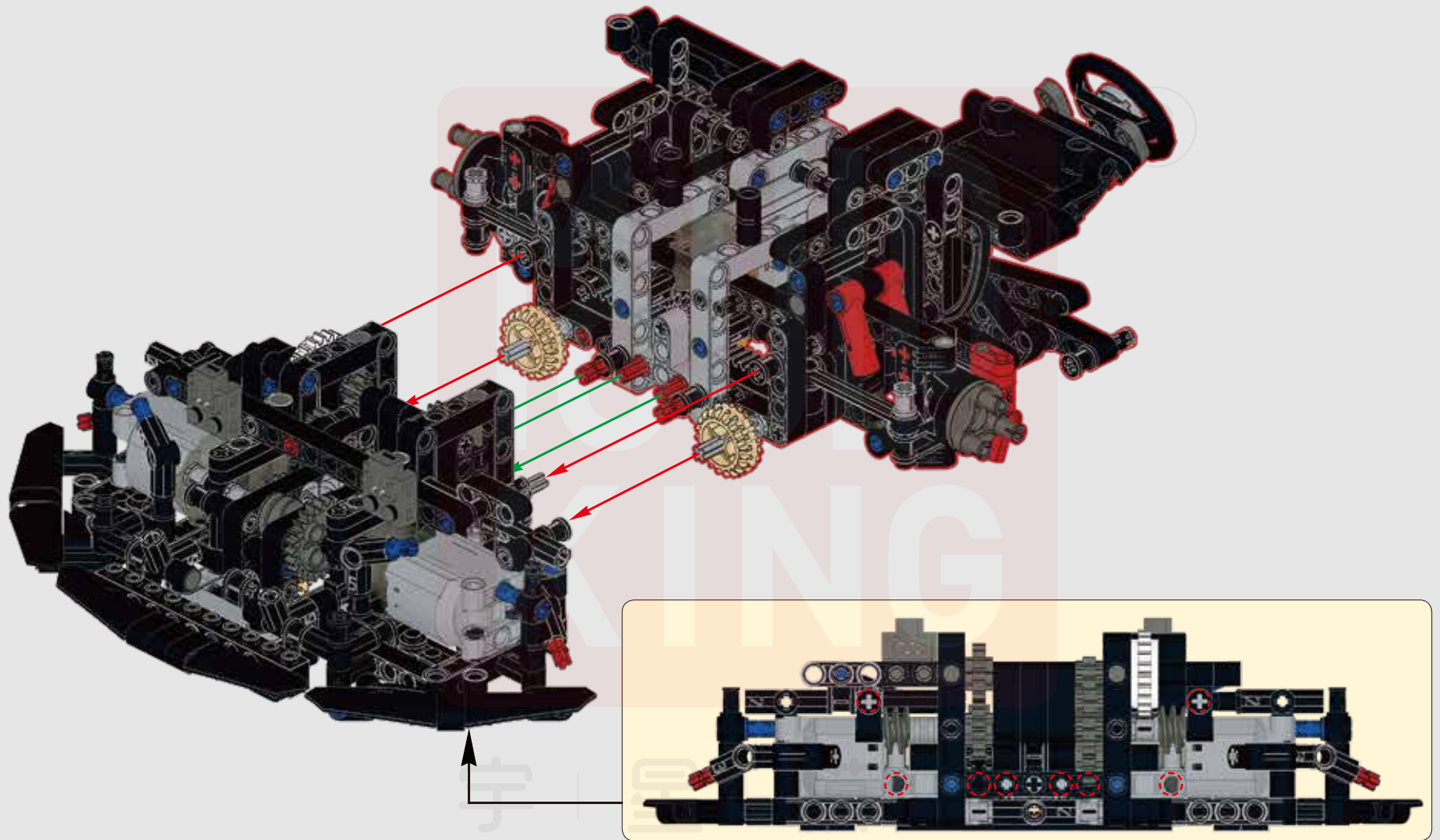

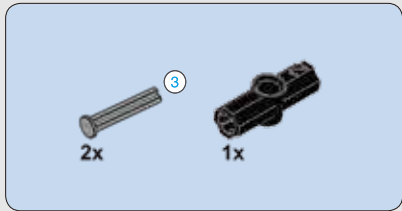

128

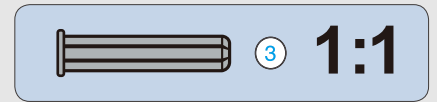
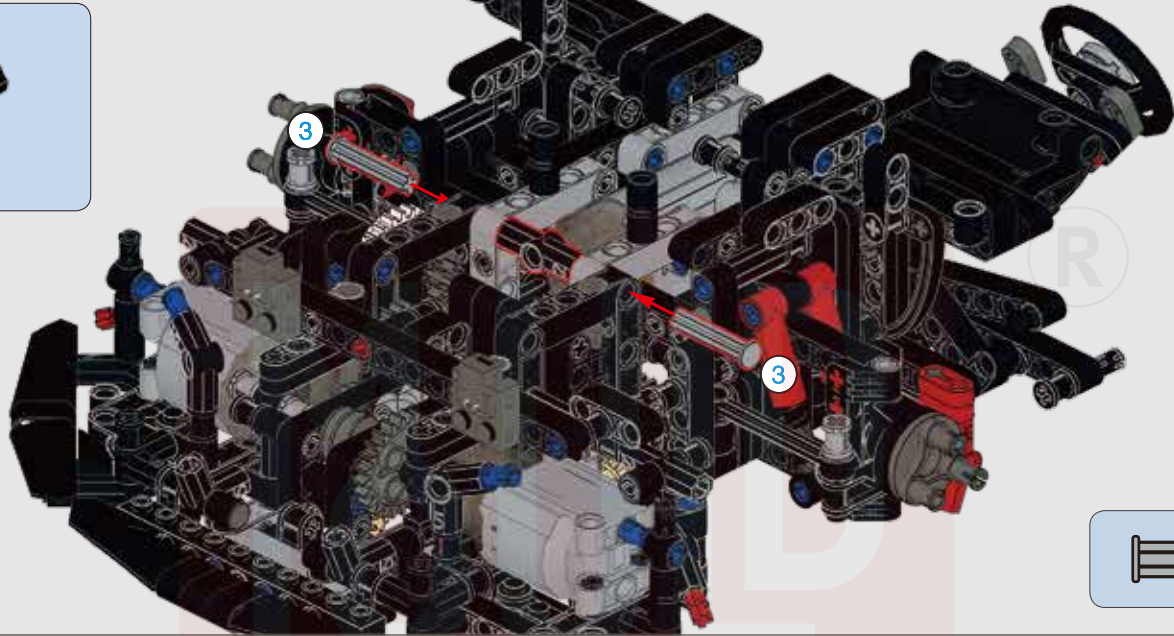

需另拿两条延长线辅助，才可测试功能。
It is necessary to take two additional extension lines to test the function.

129

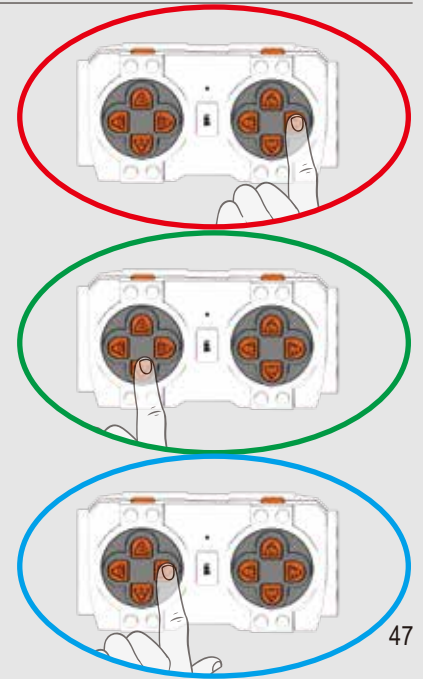
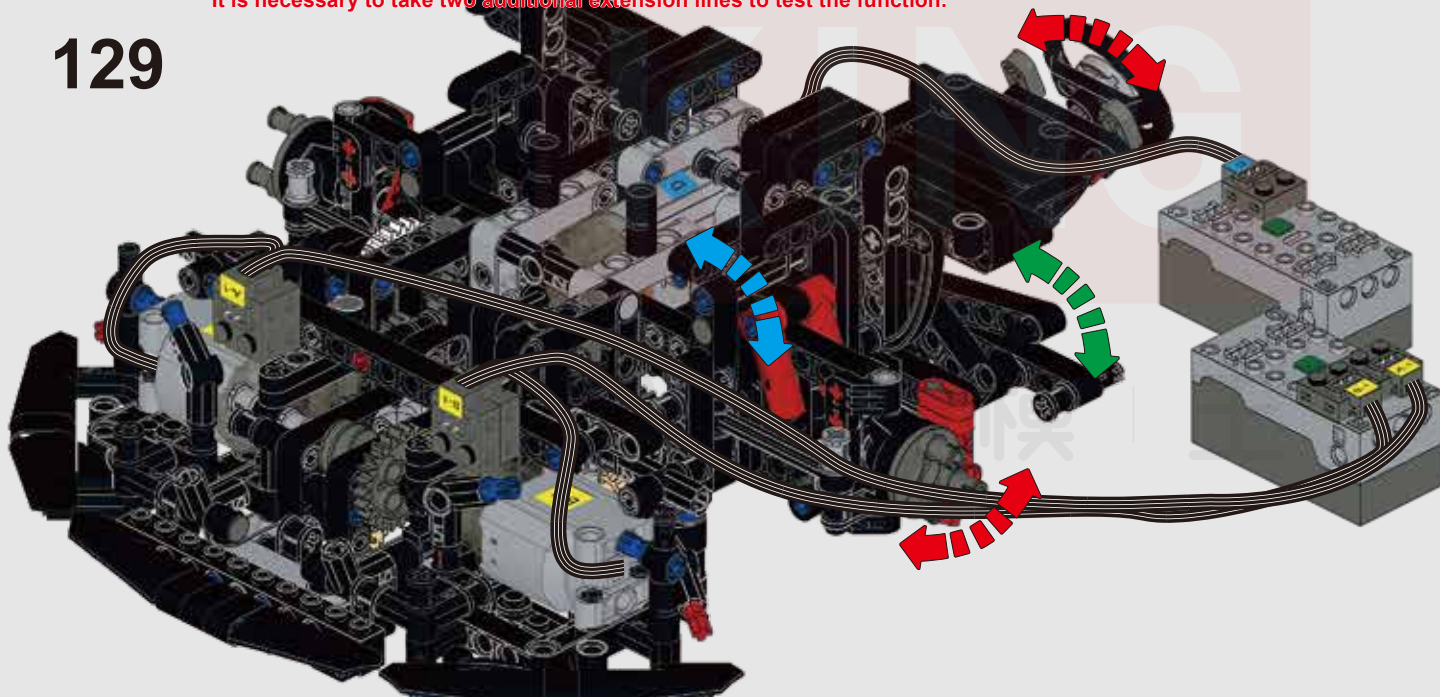

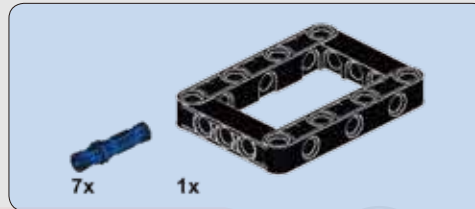

130

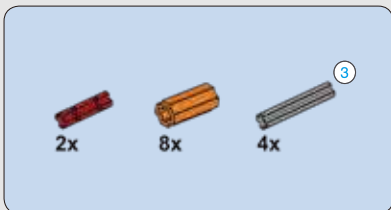
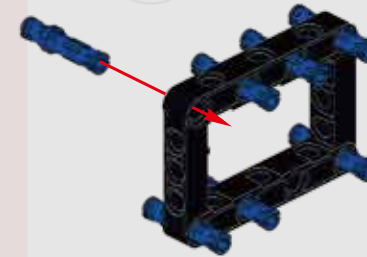

131

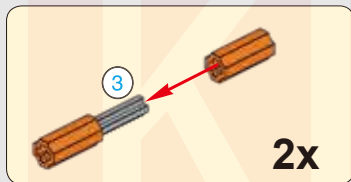
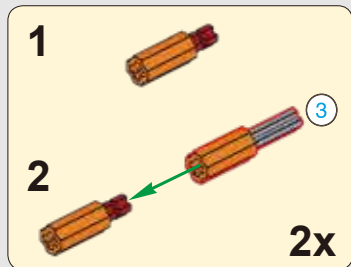

132

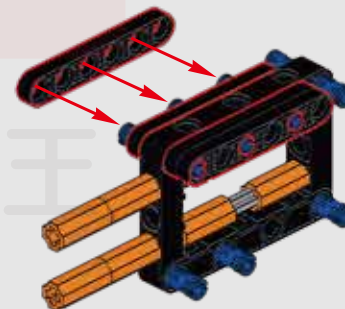
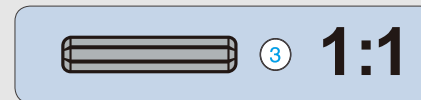

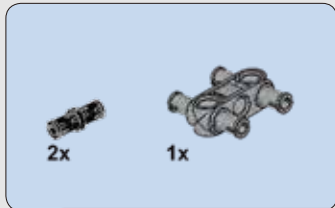

133

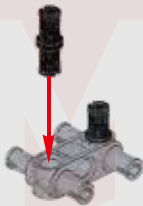

134

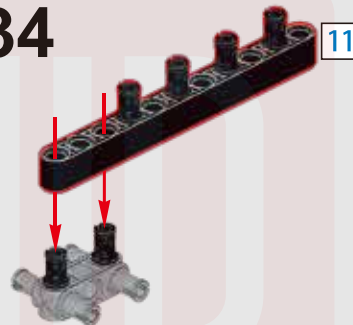

135

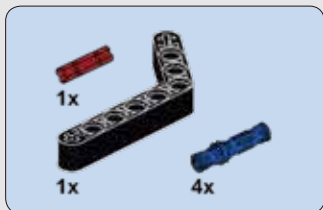

136

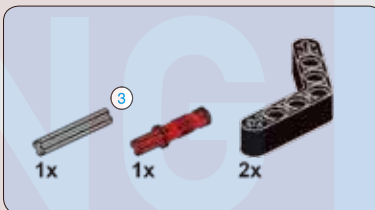

137

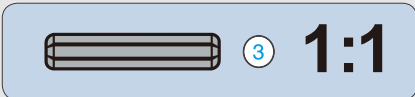
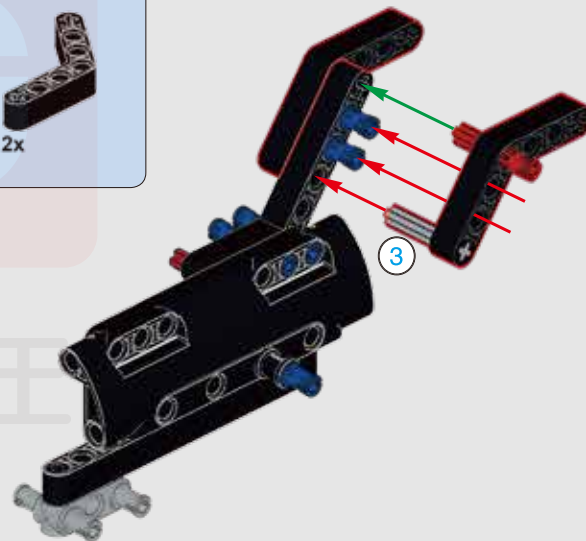

138

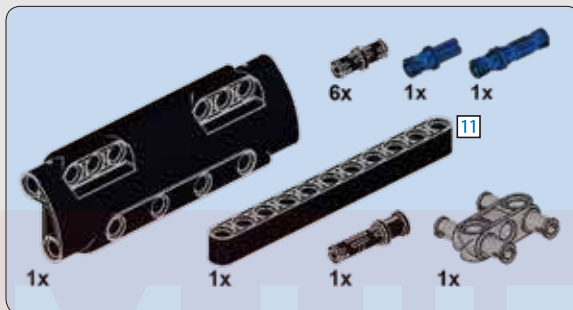

139

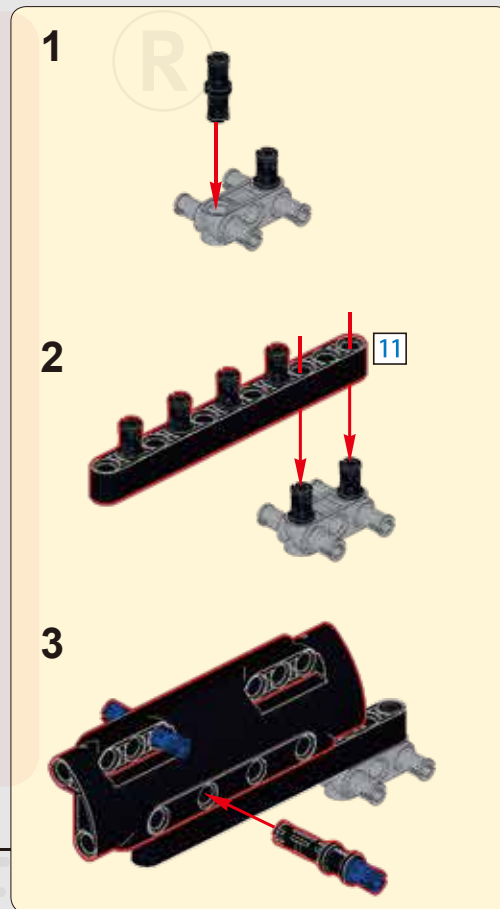
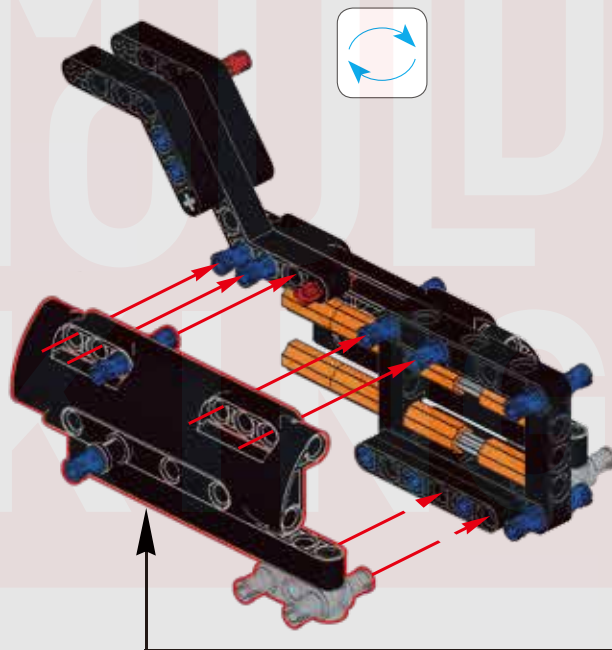
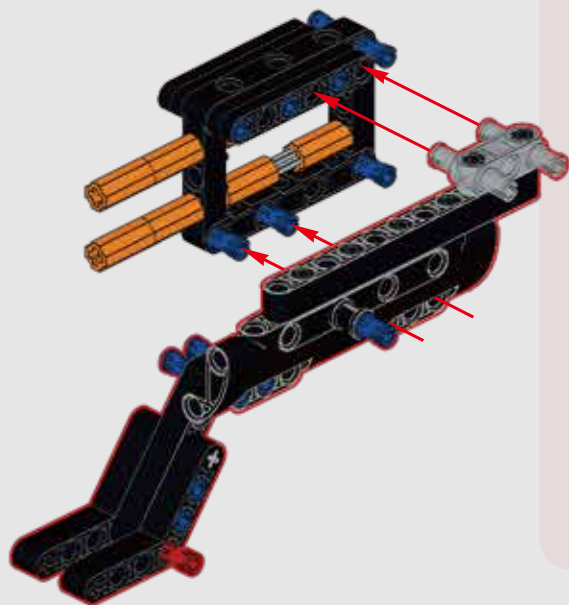

140



注意：拼装说明请参考13090 迈凯伦 P1静态说明第44-45页149-157步
Note: Please refer to step 149-157 on page 44-45 of 13090 McLaren P1 Manual Version for assembly instructions.

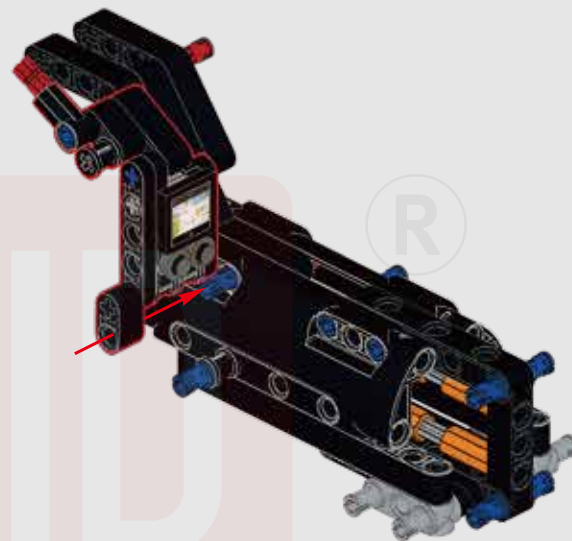

141



注意：拼装说明请参考13090 迈凯伦 P1静态说明第46页159步
Note: Please refer to step 159 on page 46 of 13090 McLaren P1 Manual Version for assembly instructions.



142



Note:Please refer to step 160-163 on page 46-47 of 13090 McLaren P1 Manual Version for assembly instructions.

注意：拼装说明请参考13090 迈凯伦P1静态说明第46-47页160-163步

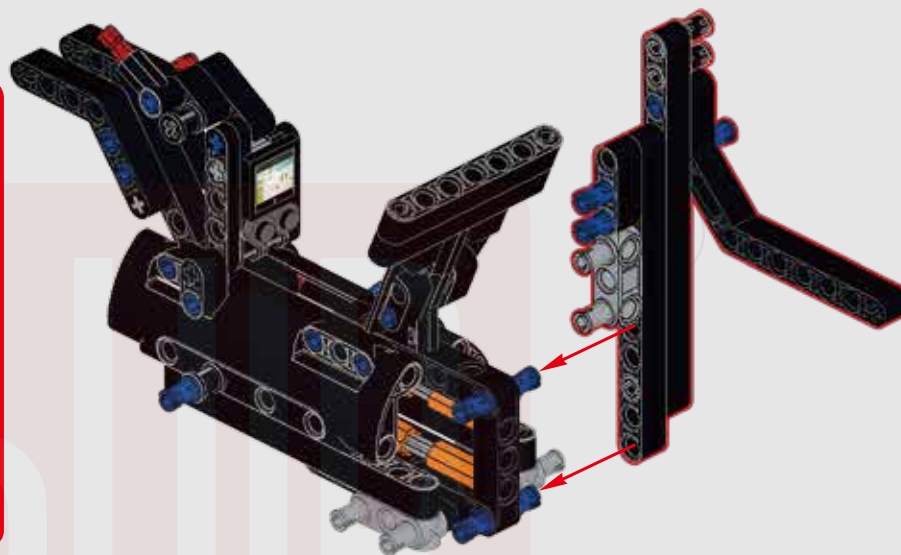

143



注意：拼装说明请参考13090迈凯伦P1静态说明第47-48页165-167步

Note:Please refer to step 165-167 on page 47-48 of 13090 McLaren P1 Manual Version for assembly instructions.

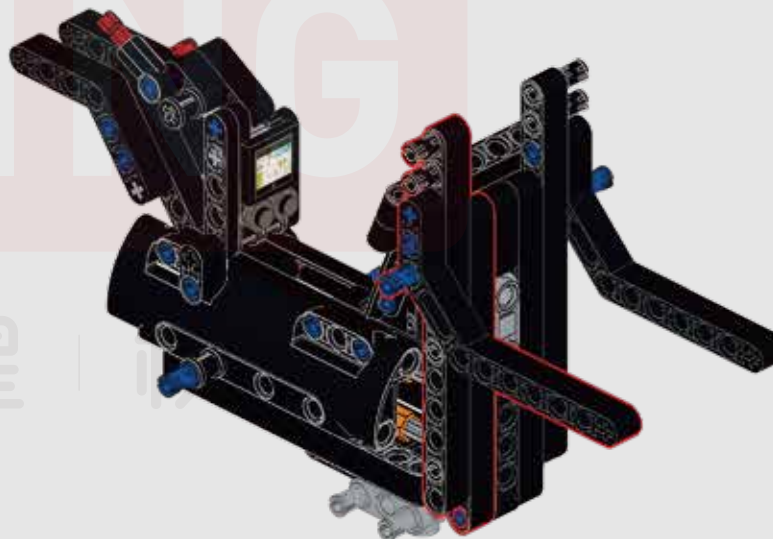

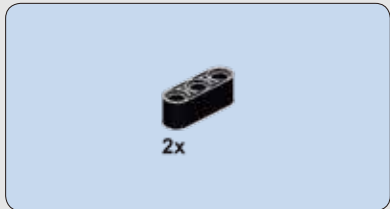

144

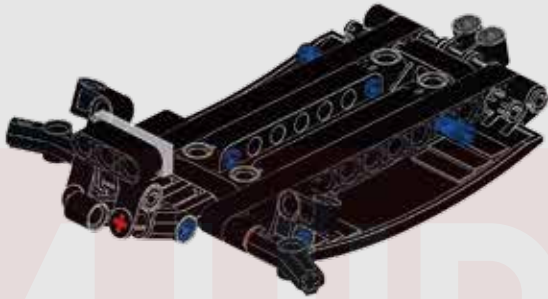

注意：拼装说明请参考13090迈凯伦P1静态说明第48-50页169-175步
Note: Please refer to step 169-175 on page 48-50 of 13090 McLaren P1 Manual Version for assembly instructions.

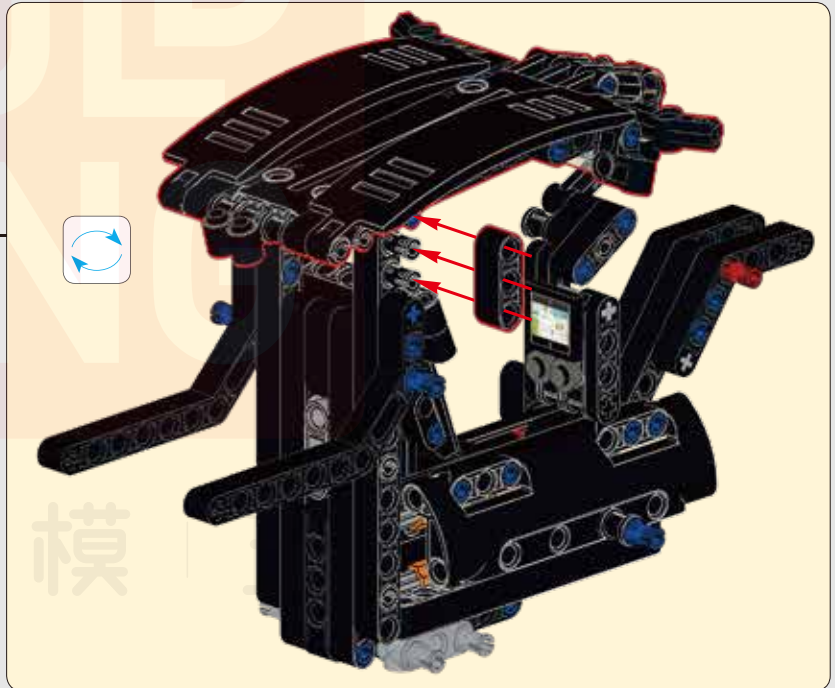
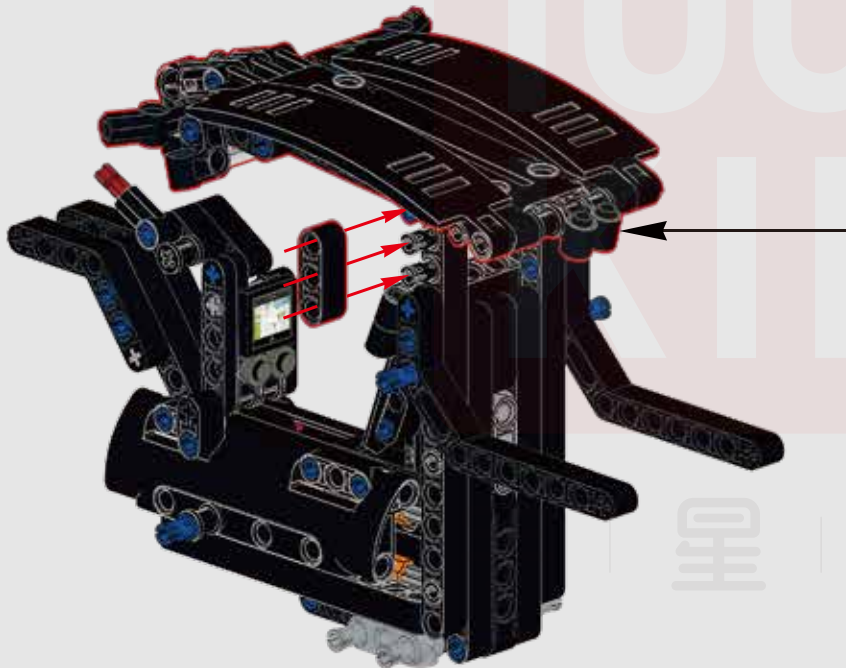

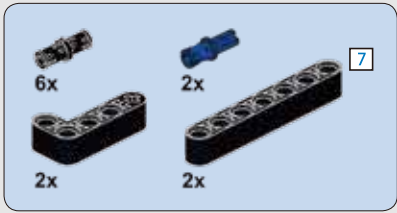

145

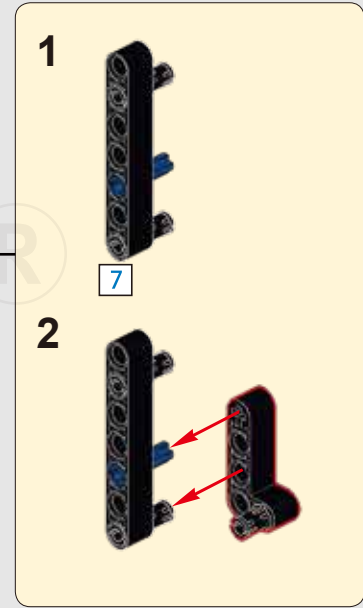
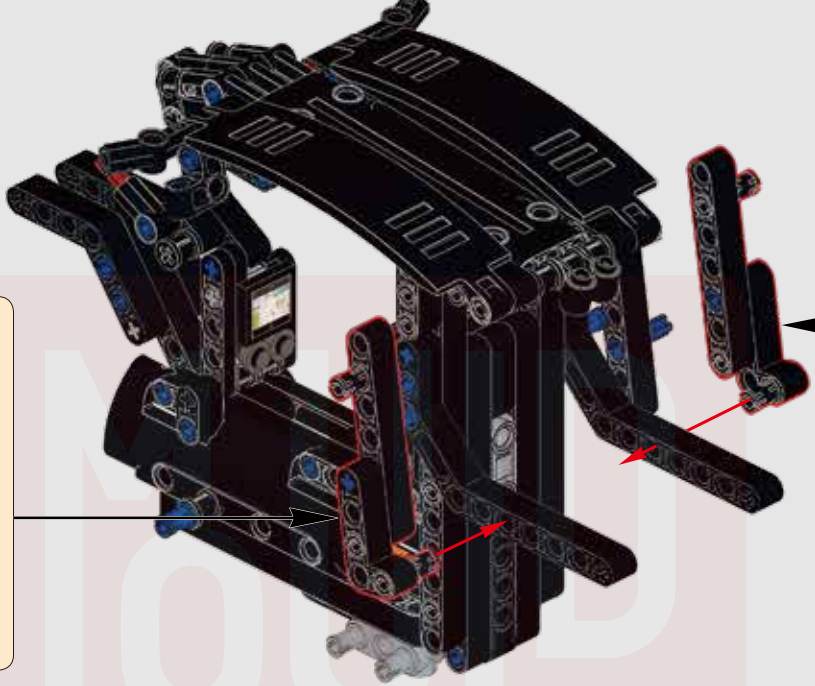
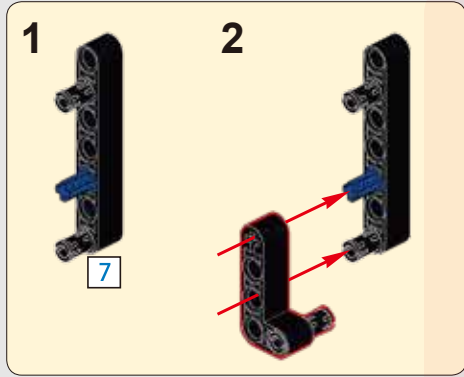

146

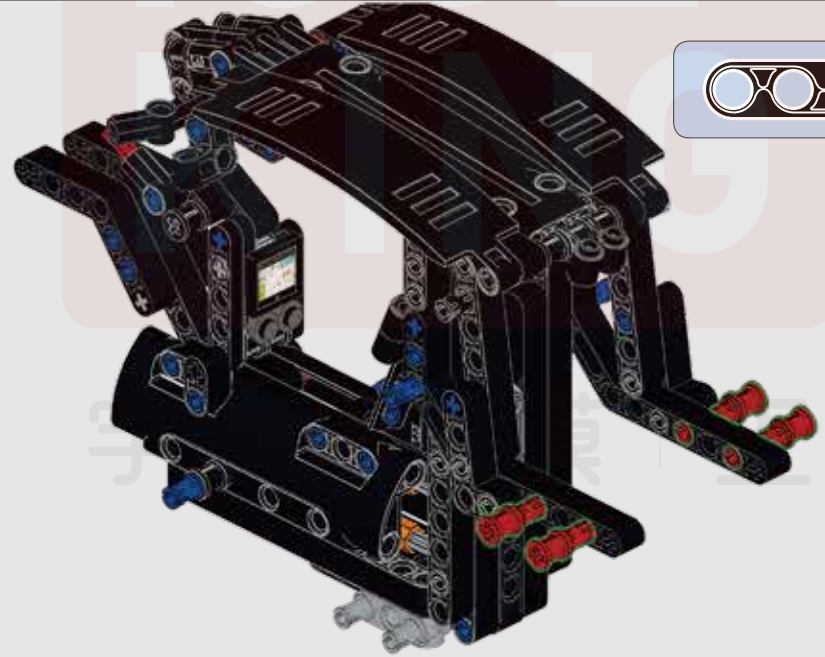

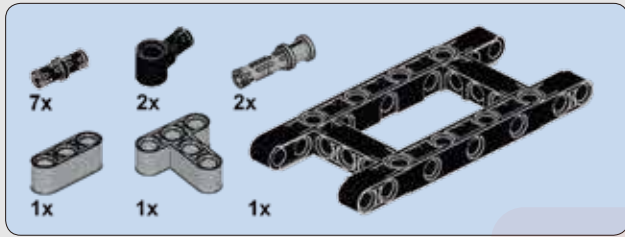

147

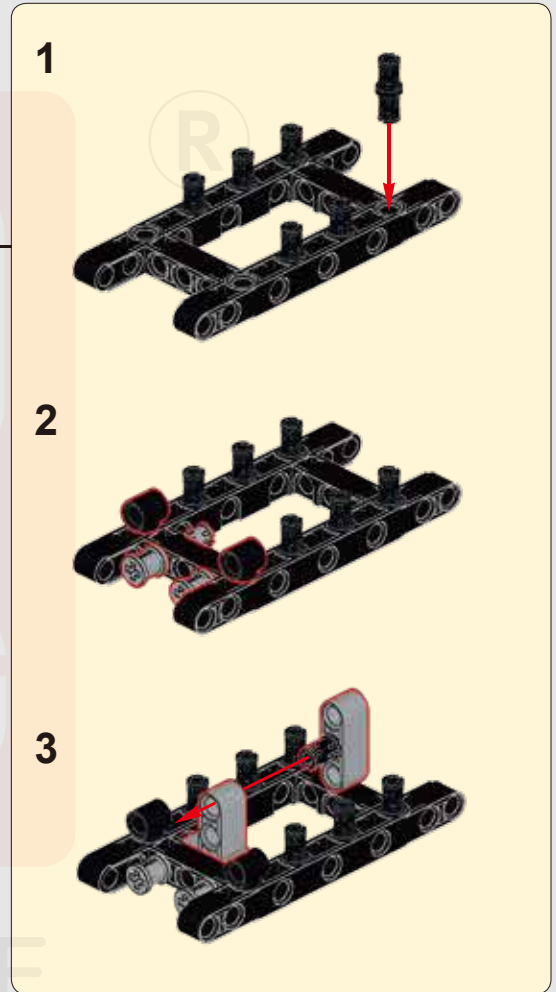
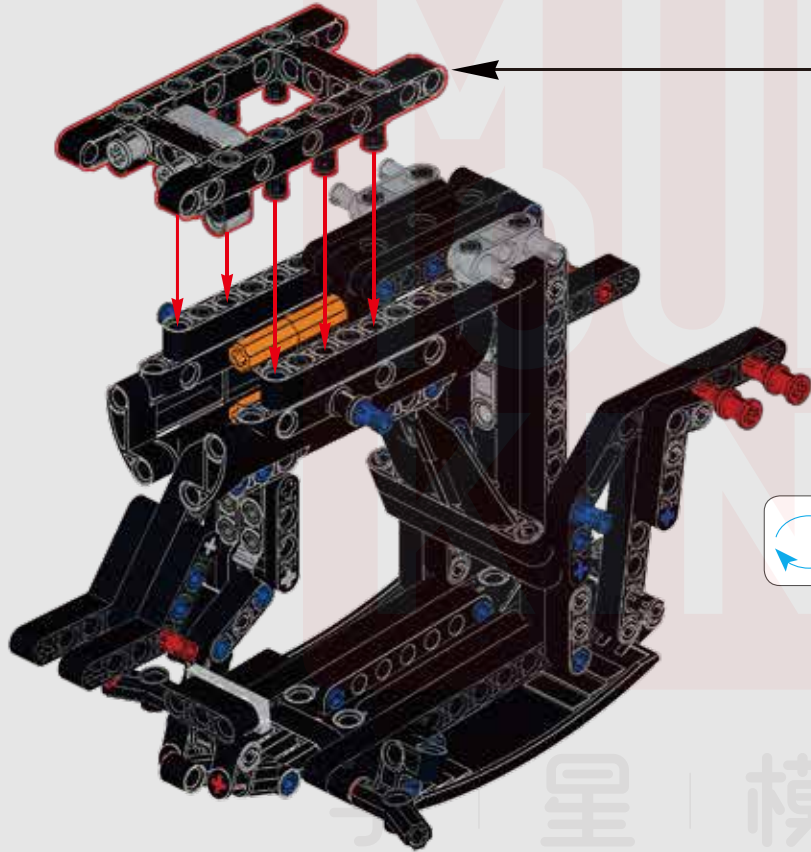

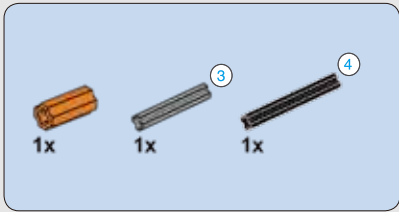

148

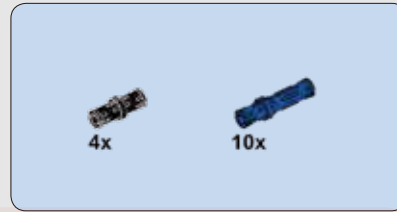

149

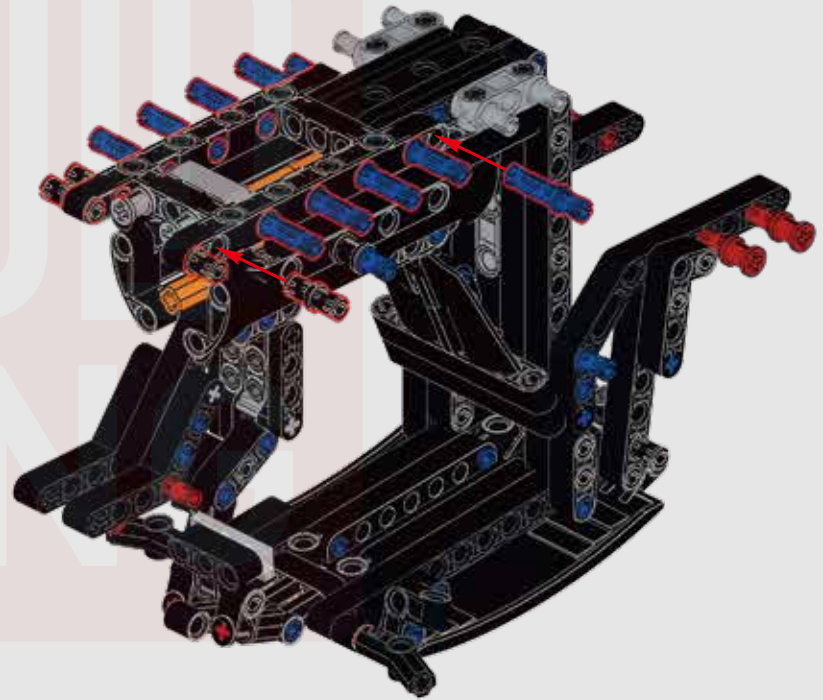

宇 | 星 | 模 | 王





150



注意：拼装说明请参考13090 迈凯伦 P1静态说明第54-55页183-186步
Note: Please refer to step 183-186 on page 54-55 of 13090 McLaren P1 Manual Version for assembly instructions.

151





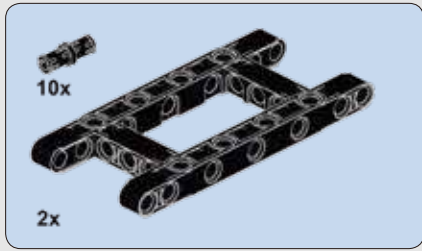

153

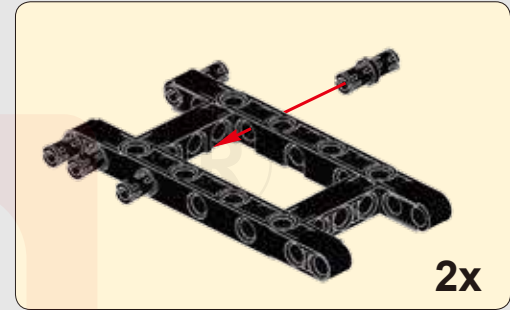
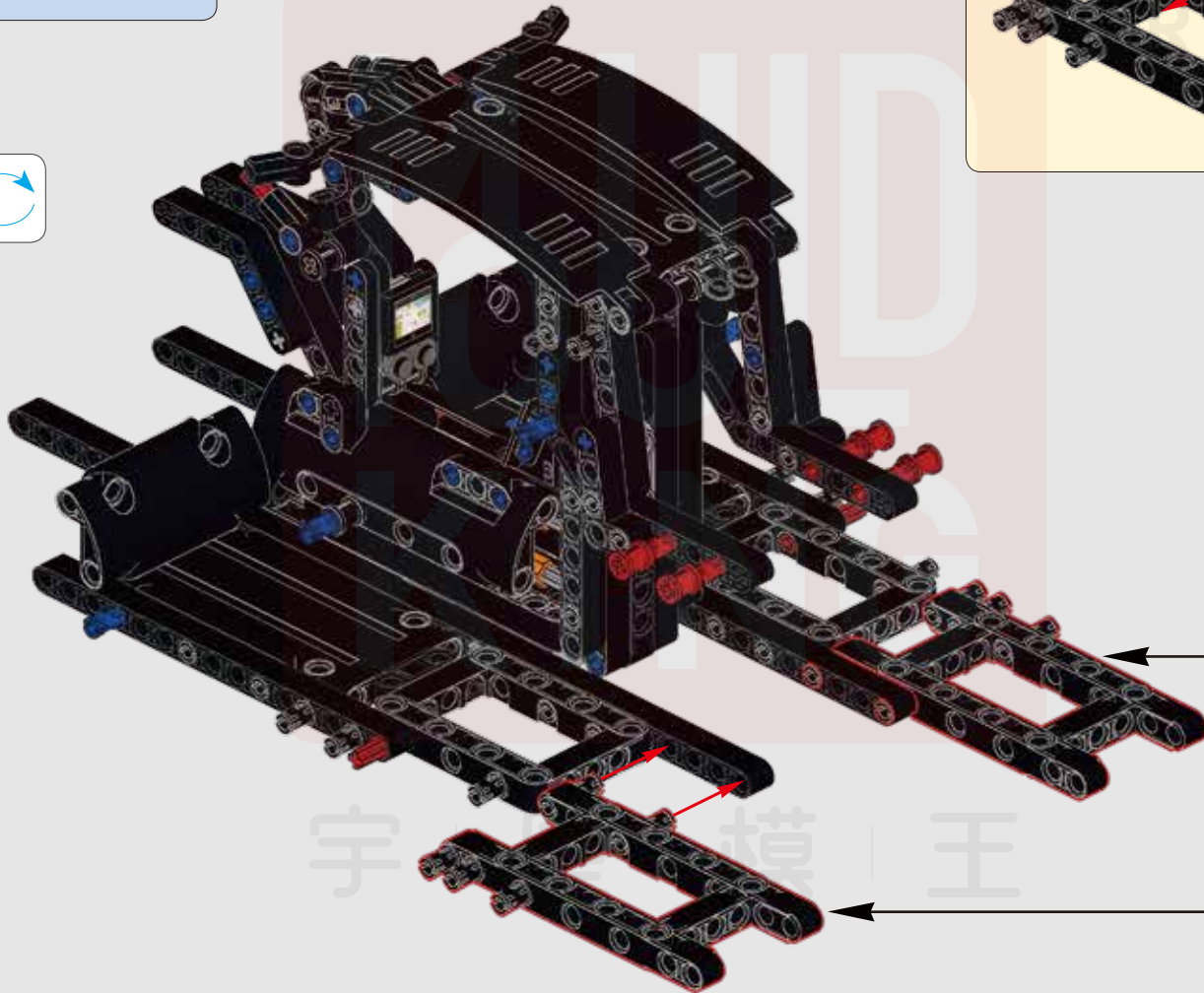

宇模王

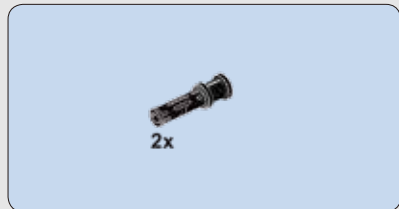

154

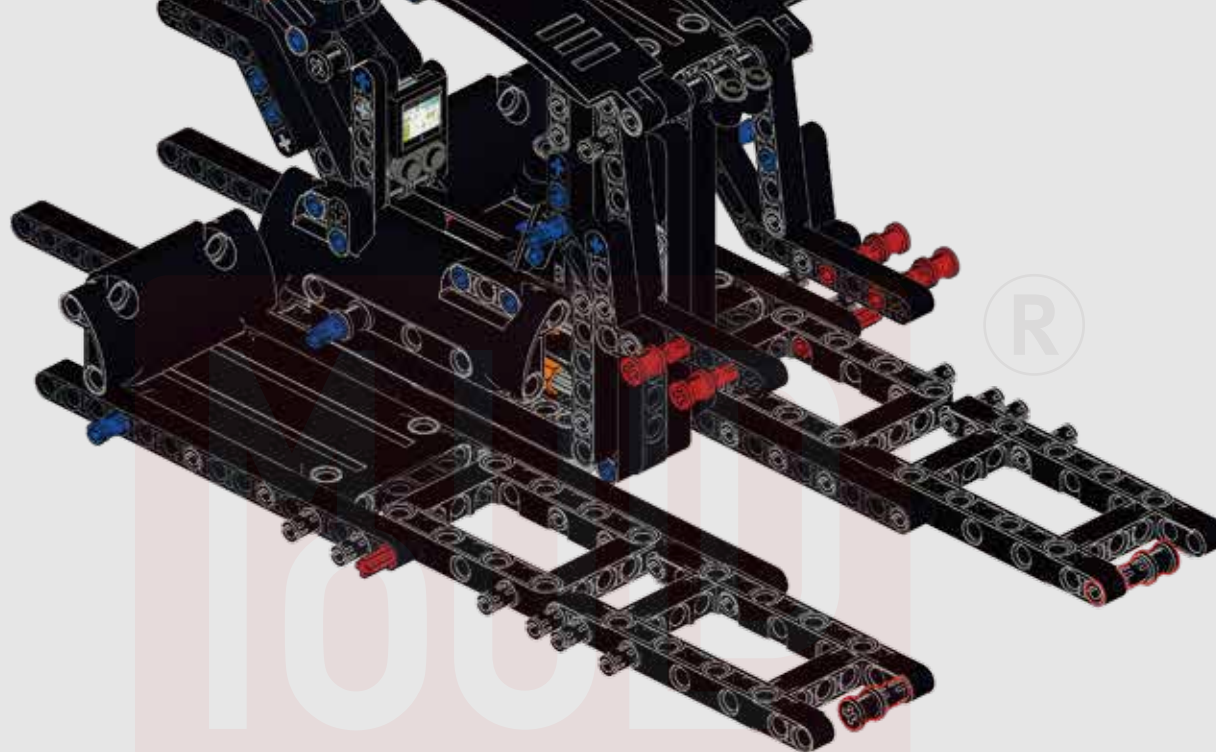

155



注意：拼装说明请参考13090
迈凯伦P1静态说明第59-60页
195-197步

**Note: Please refer to step 195-197
on page 59-60 of 13090 McLaren
P1 Manual Version for assembly
instructions.**



注意：拼装说明请参考13090
迈凯伦P1静态说明第60页198-200步

**Note: Please refer to step 198-200
on page 60 of 13090 McLaren
P1 Manual Version for assembly
instructions.**

156

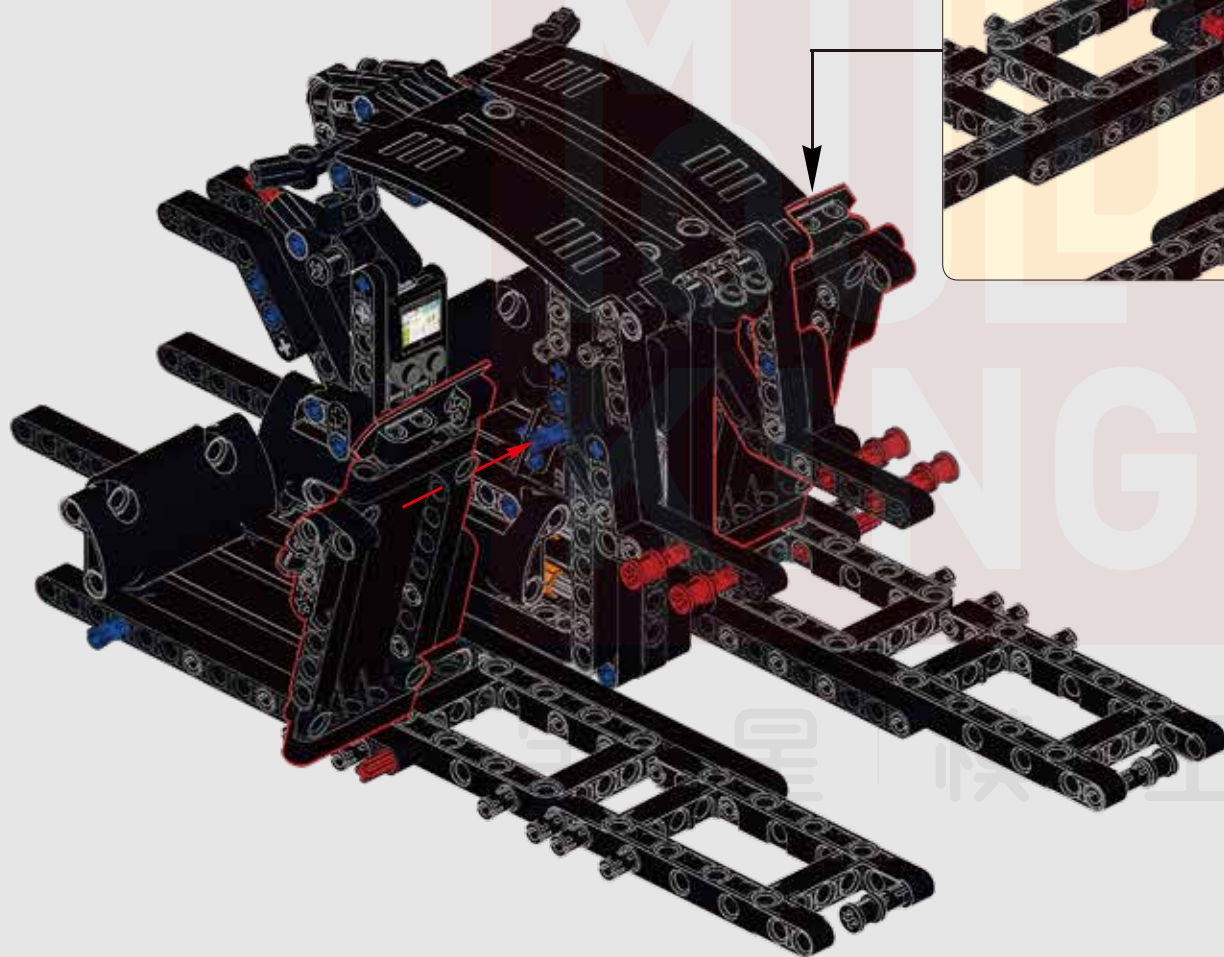

157



注意：拼装说明请参考13090迈凯伦P1静态说明第62-65页202-220步
Note: Please refer to step 202-220 on page 62-65 of 13090 McLaren P1 Manual Version for assembly instructions.



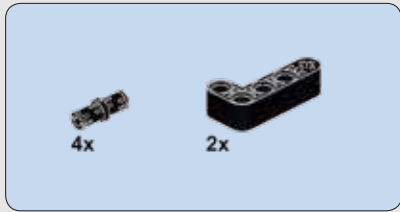

158

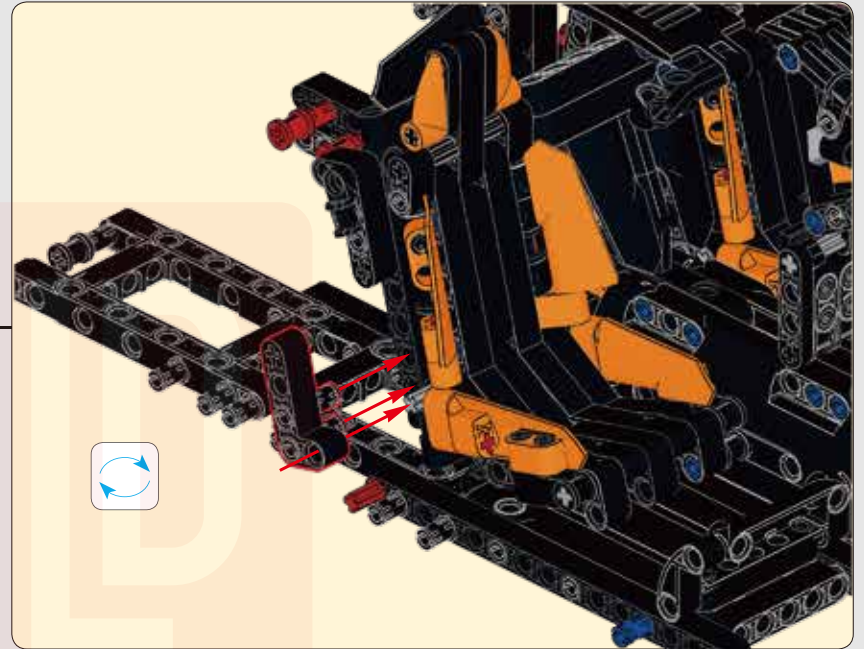
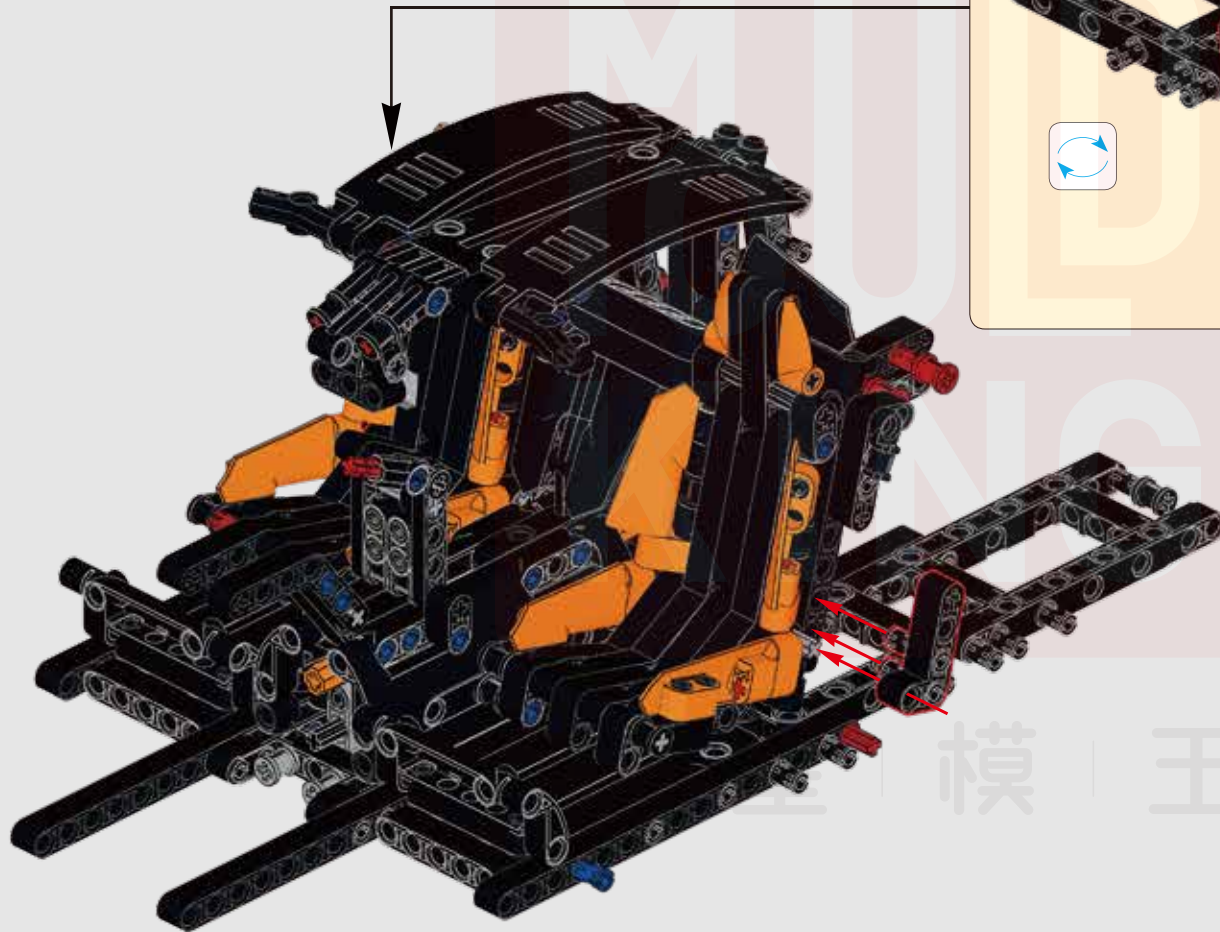

模王

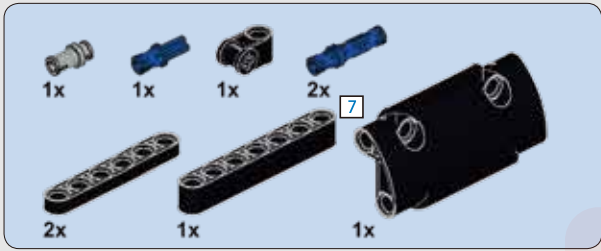

159

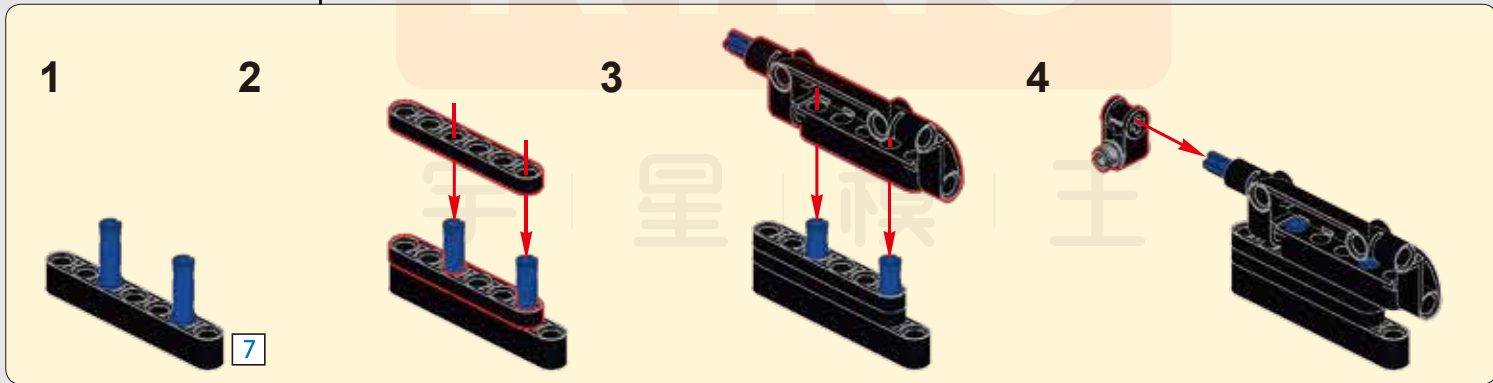
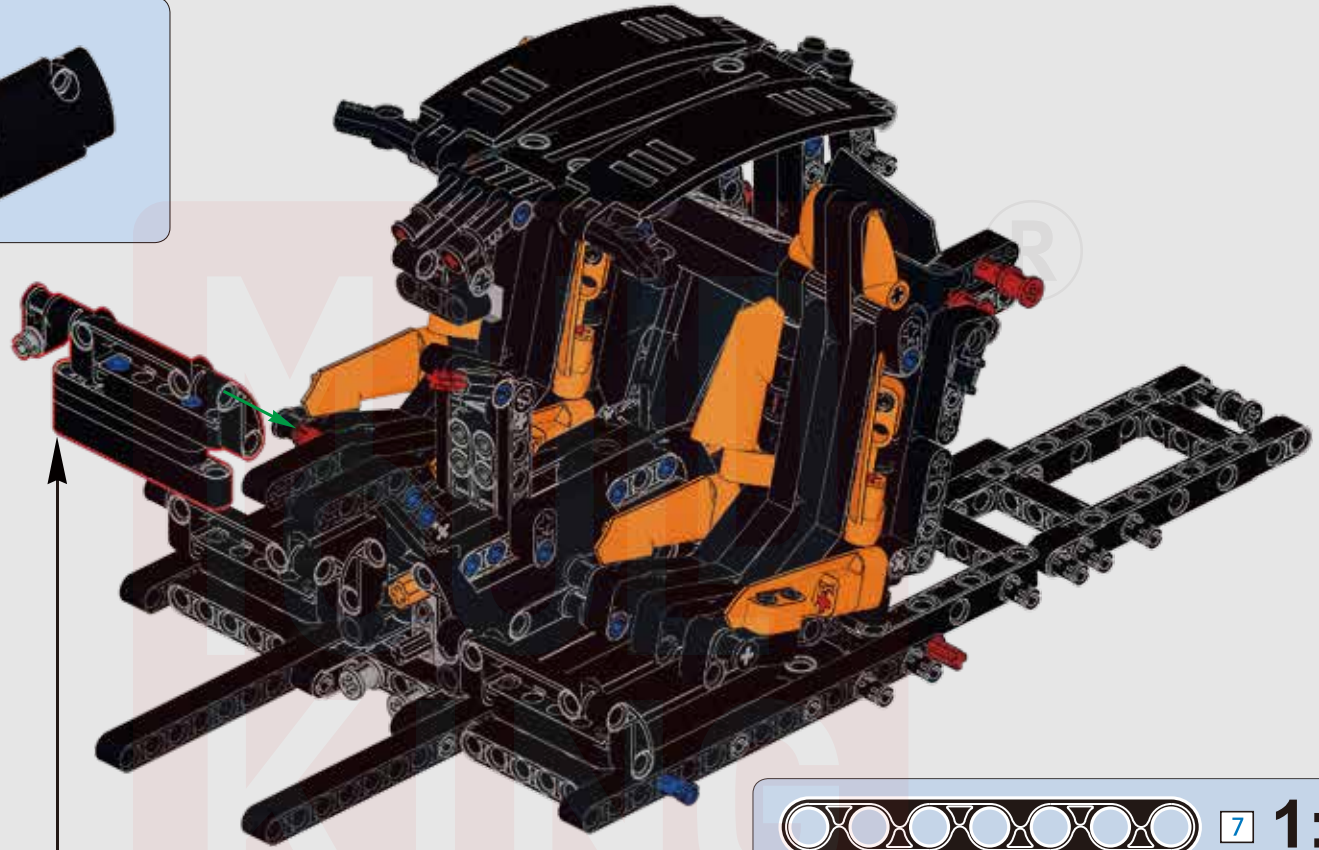

160



注意：拼装说明请参考13090 迈凯伦 P1静态说明第69页224-228步
Note: Please refer to step 224-228 on page 69 of 13090 McLaren P1 Manual Version for assembly instructions.



注意：拼装说明请参考13090 迈凯伦 P1静态说明第70页229-233步
Note: Please refer to step 229-233 on page 70 of 13090 McLaren P1 Manual Version for assembly instructions.

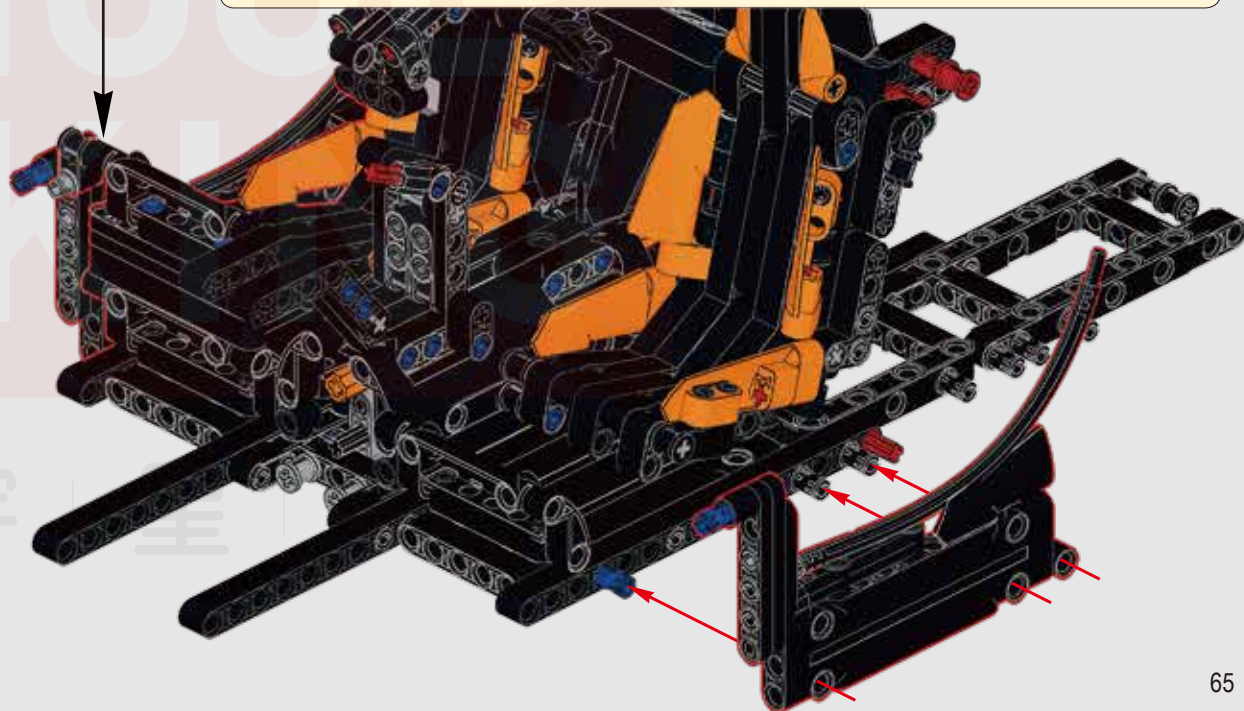
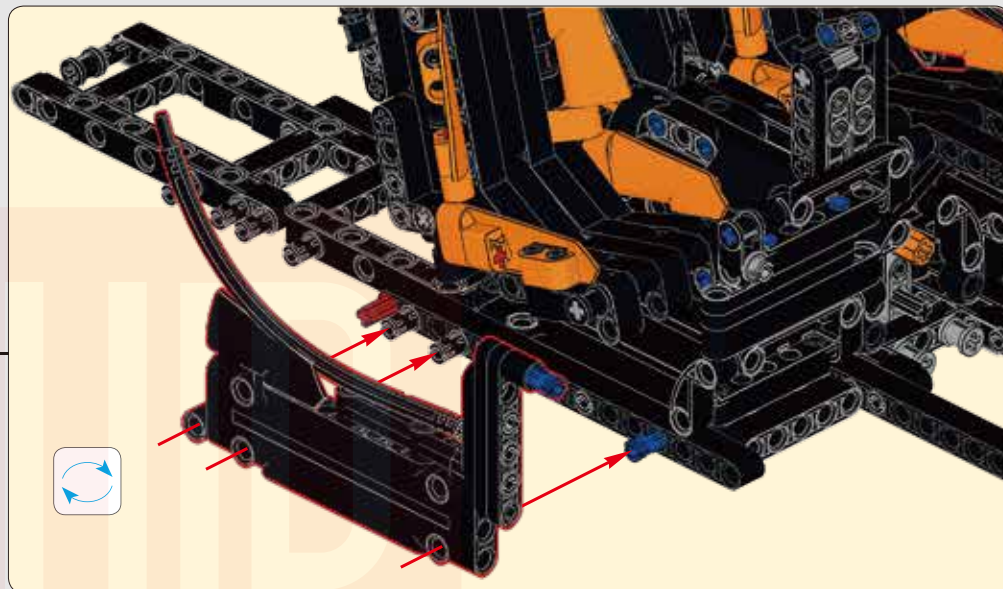

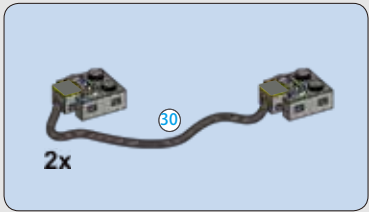

161

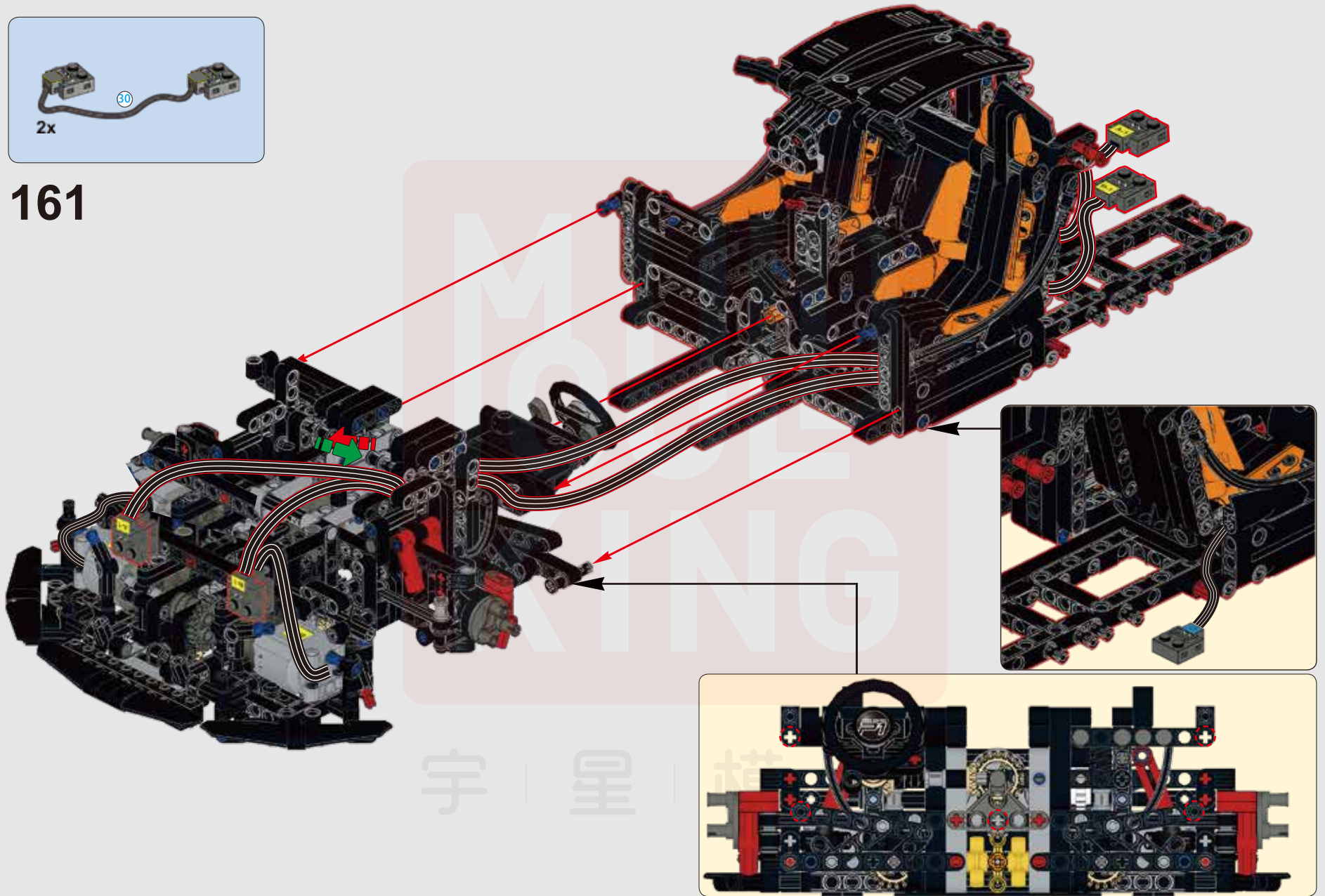



162

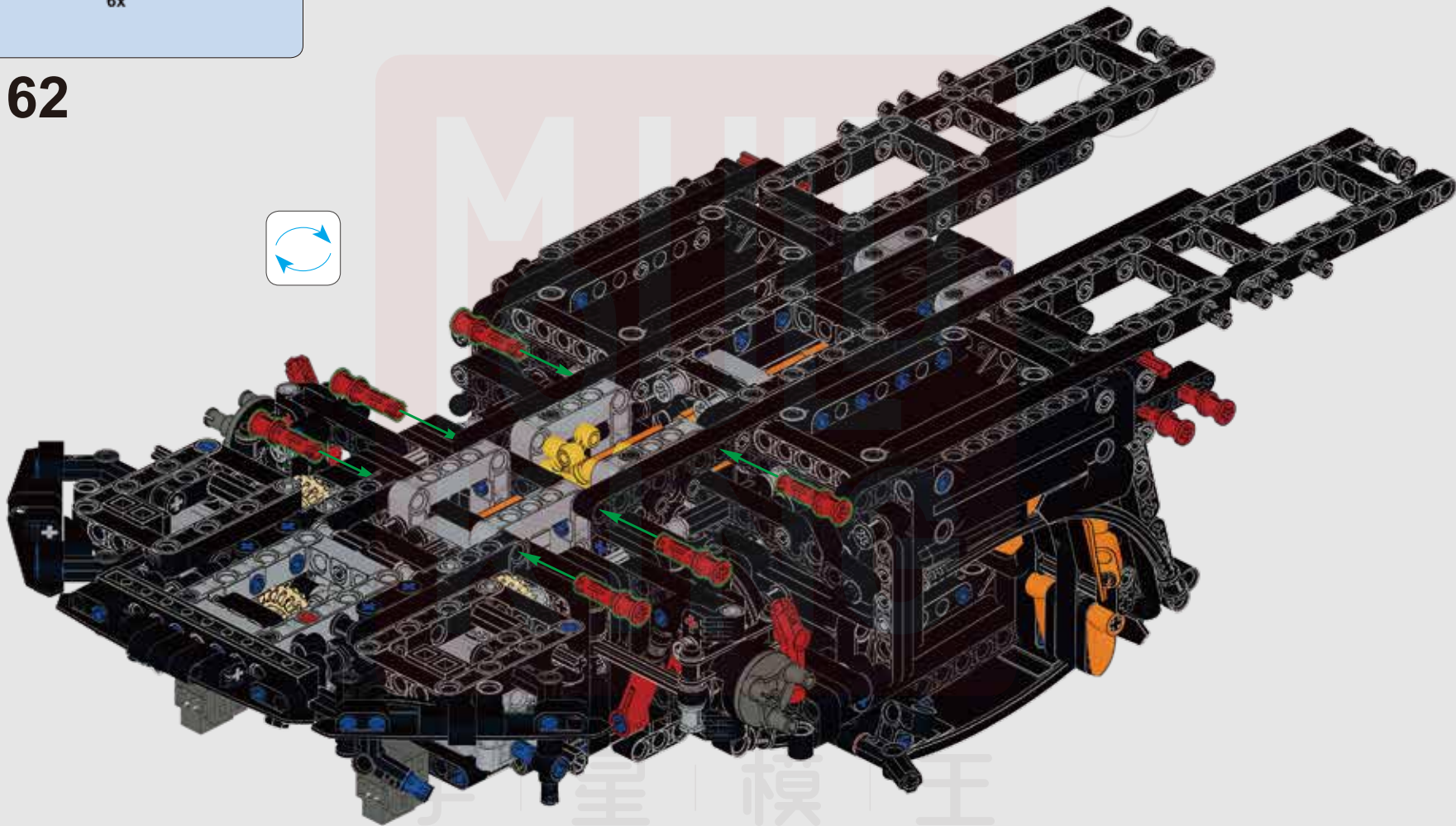

星模王

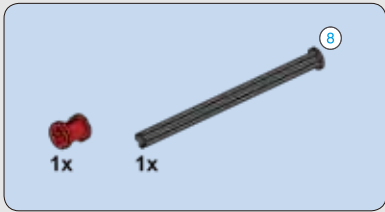

163

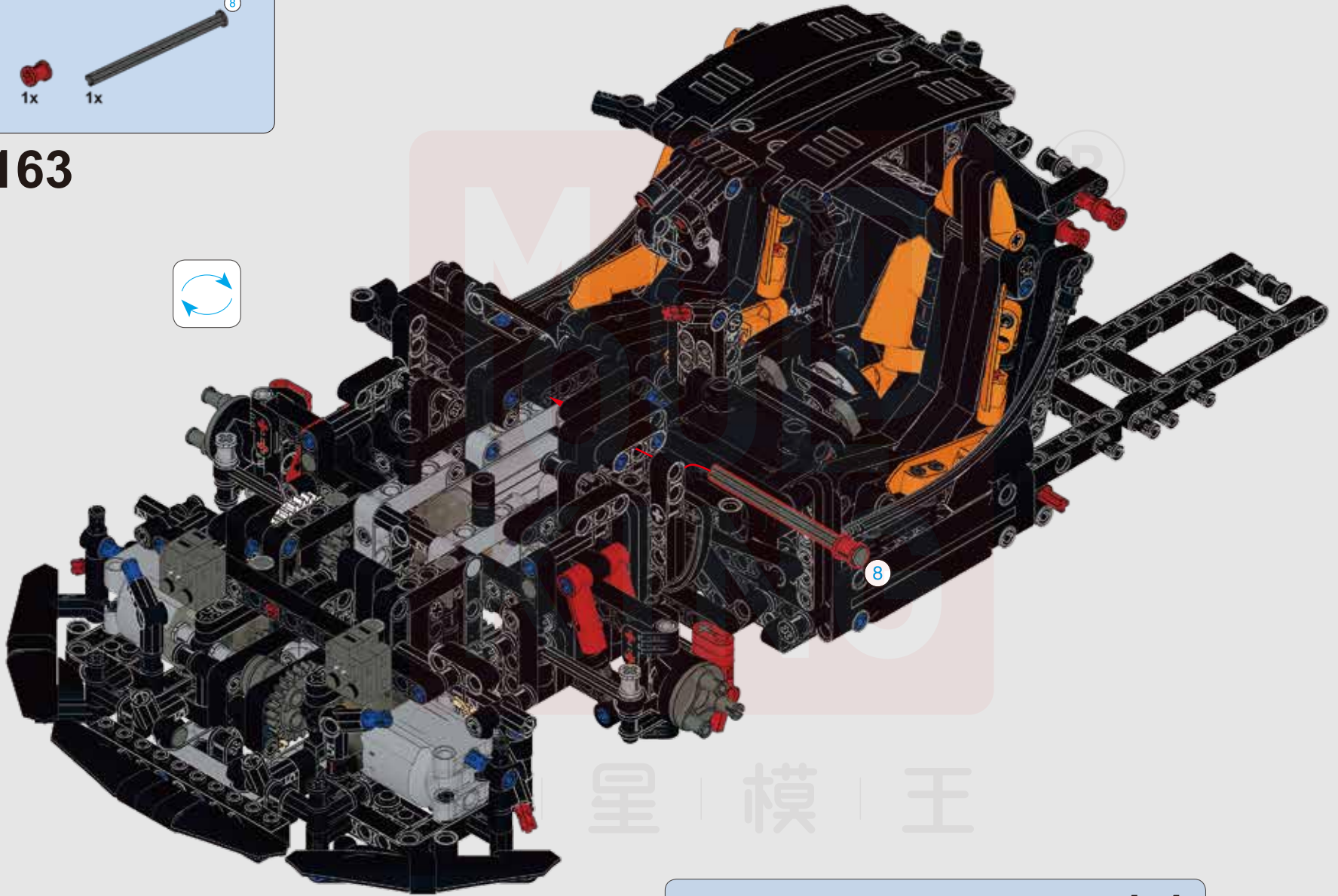

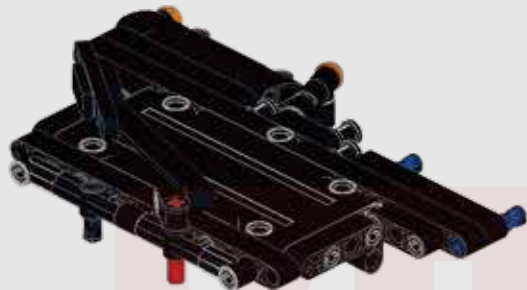

注意：拼装说明请参考13090 迈凯伦P1静态说明第75-77页238-245步
Note: Please refer to step 238-245 on page 75-77 of 13090 McLaren P1 Manual Version for assembly instructions.

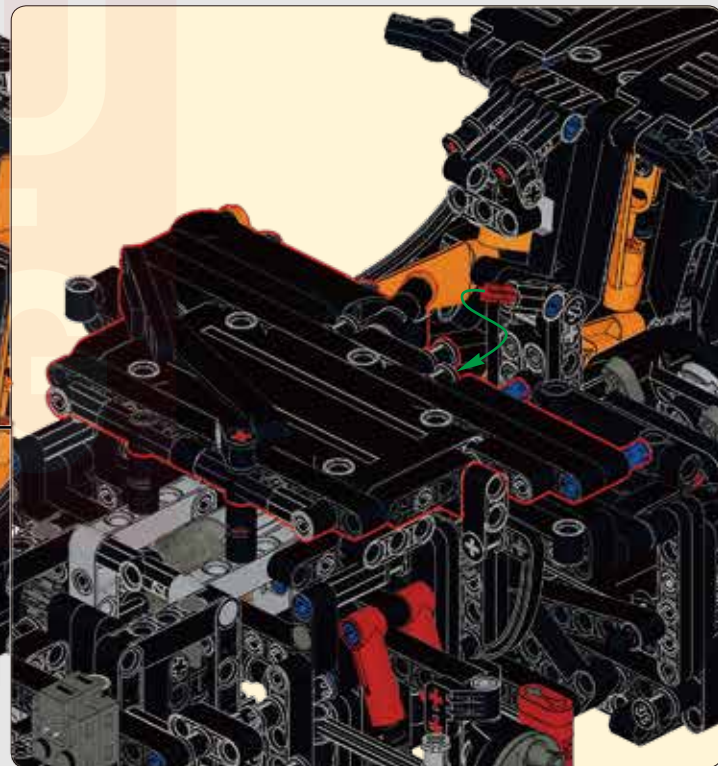
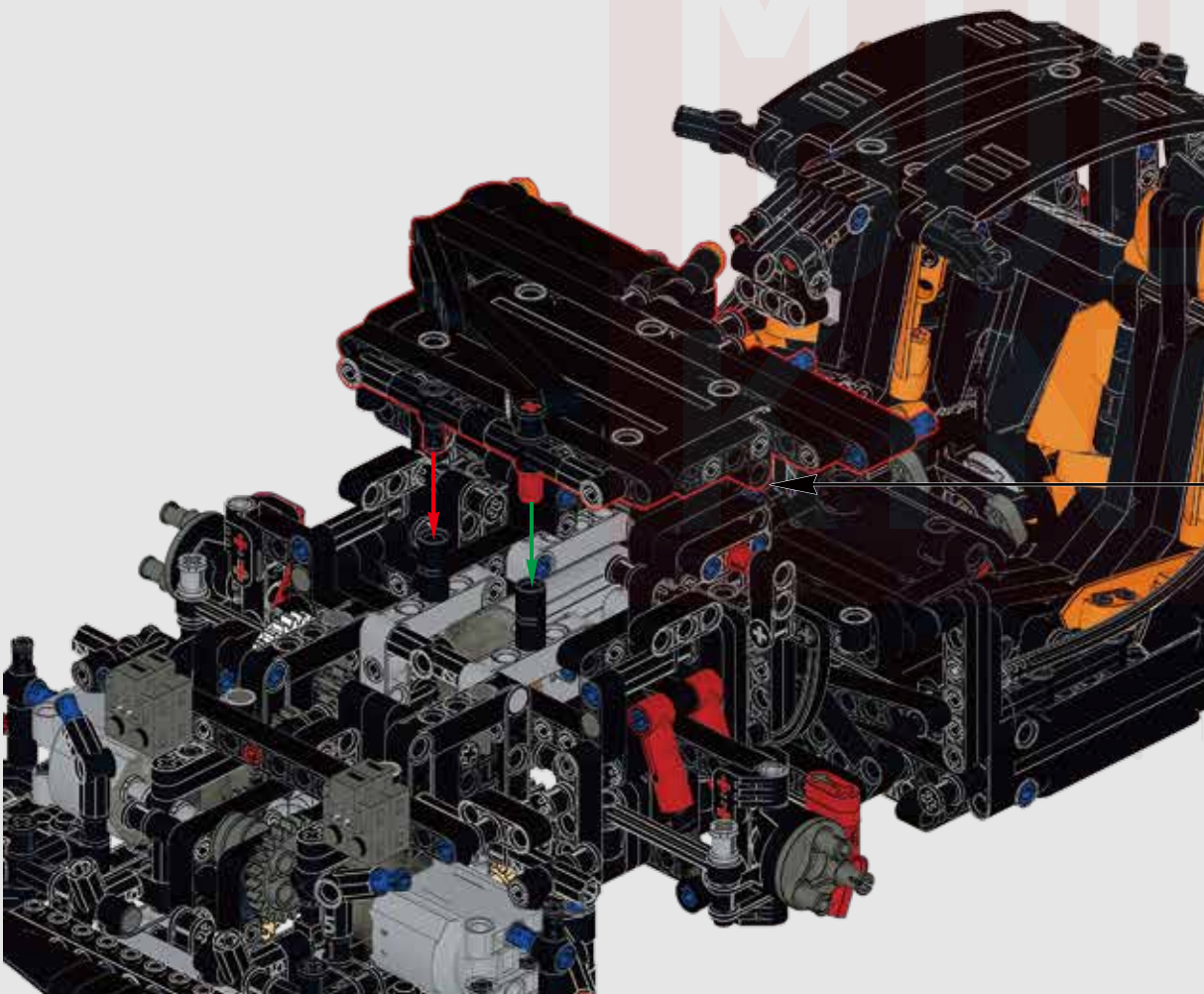

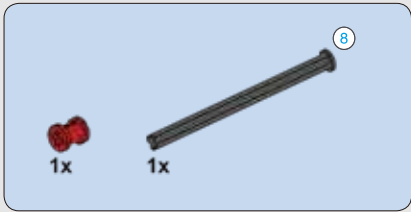

165

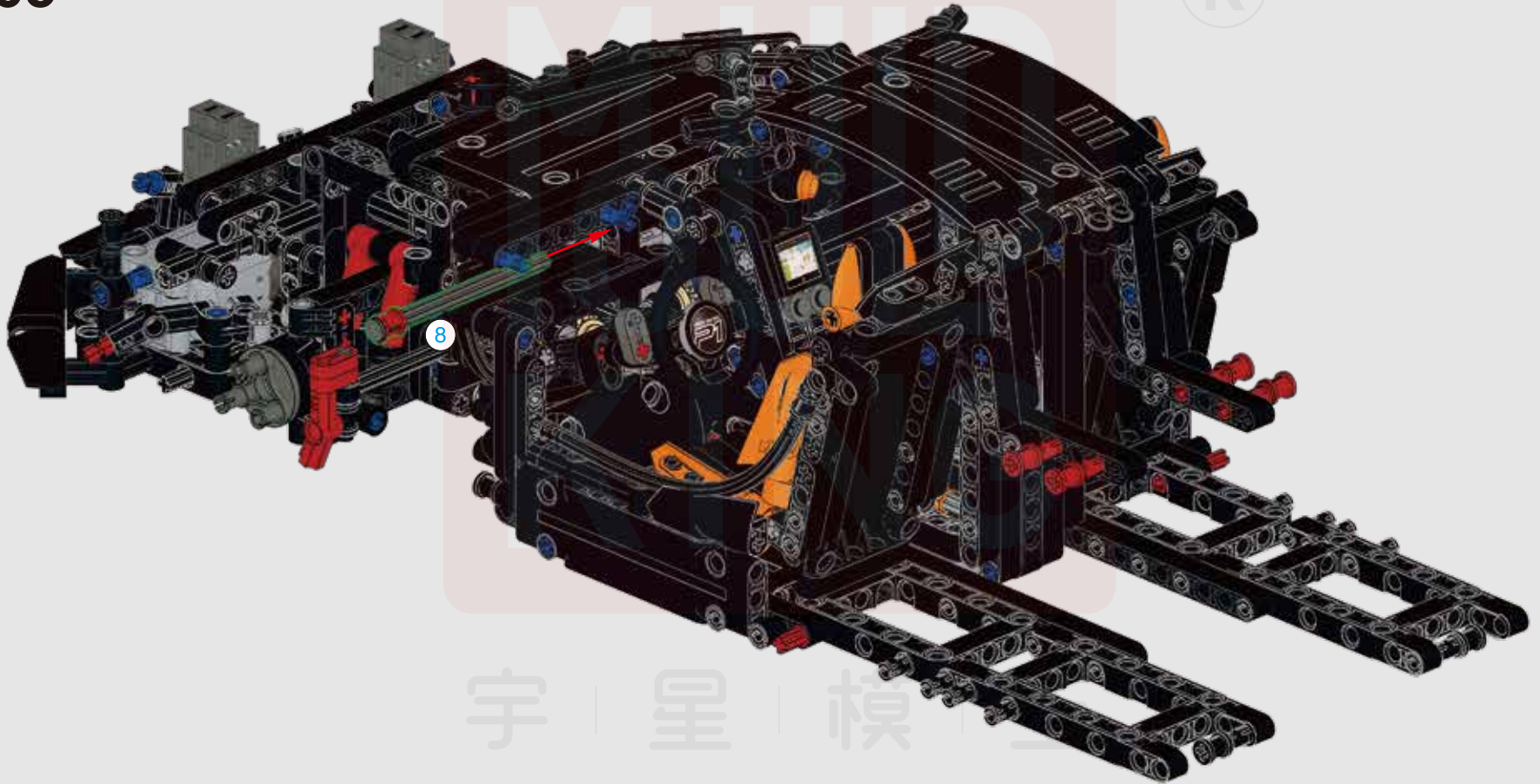

宇 | 星 | 模 | 二

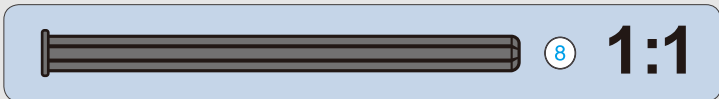

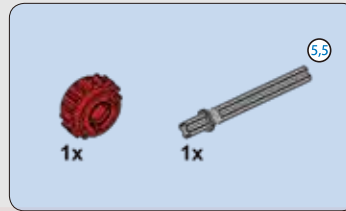

166

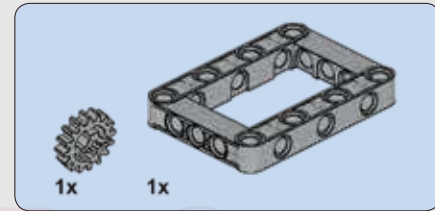

167

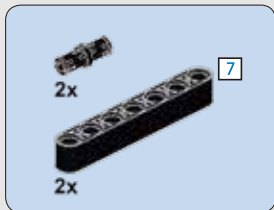
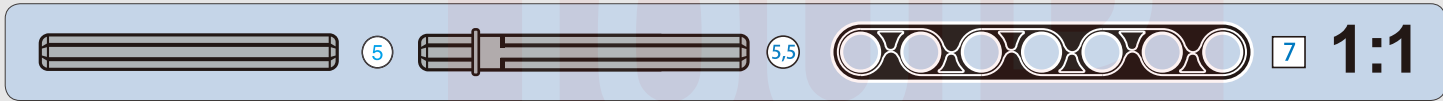
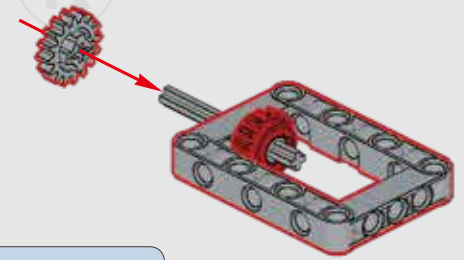
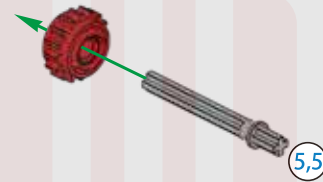

168

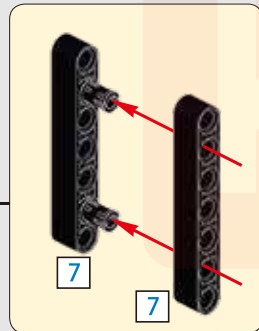

169

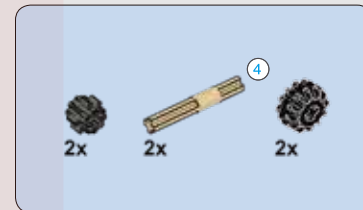
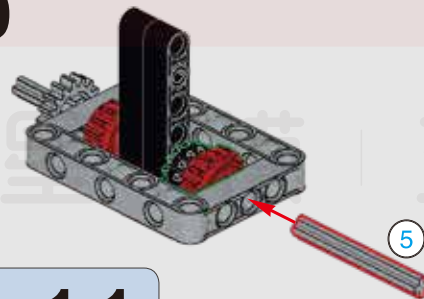

170

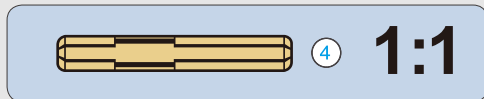
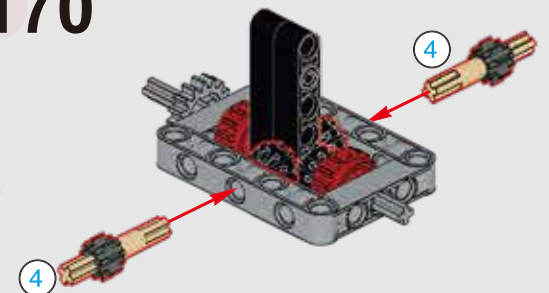
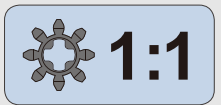

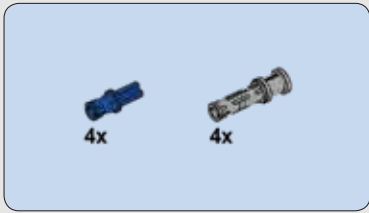

171

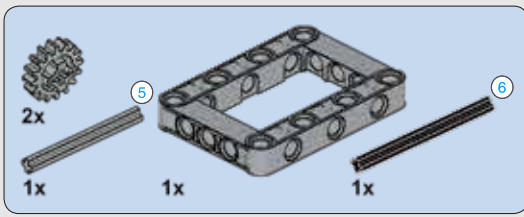
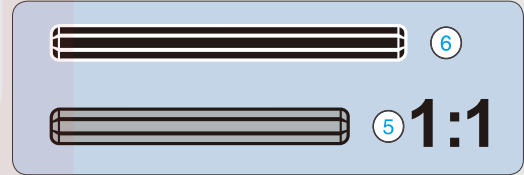
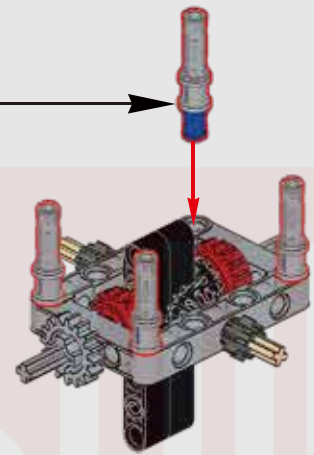
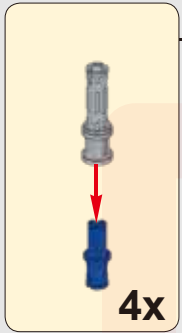

172

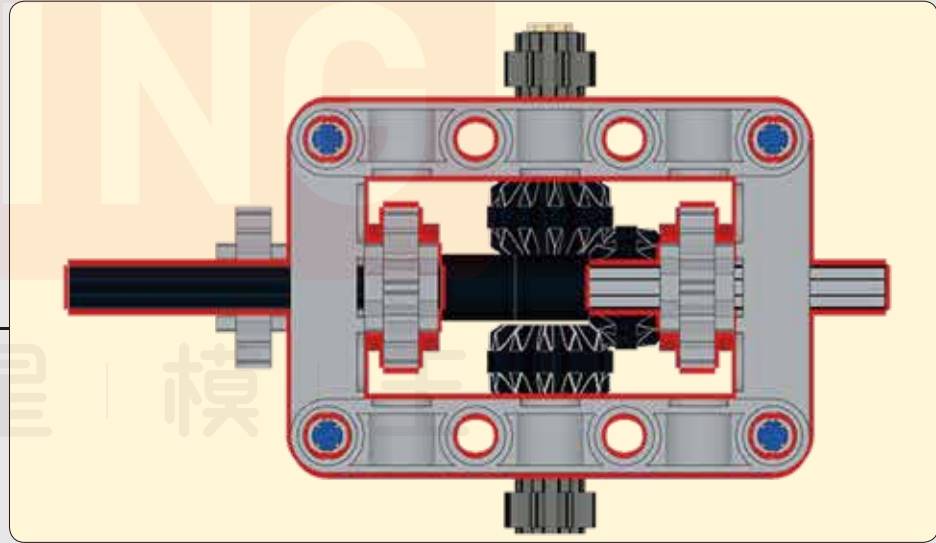
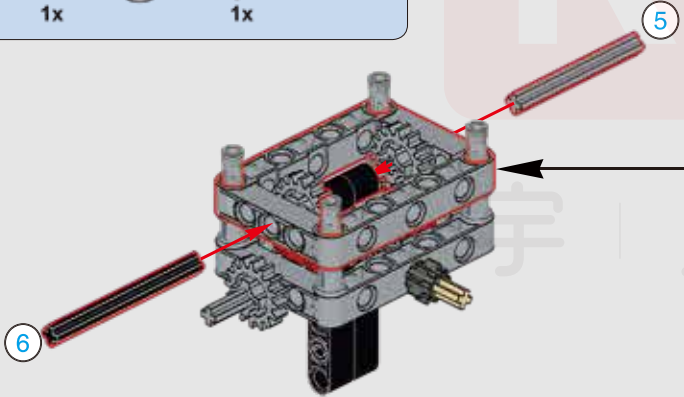

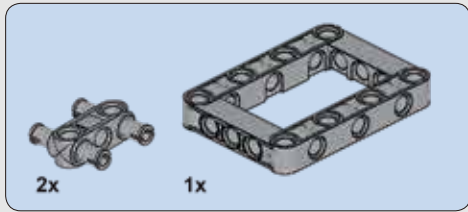

173

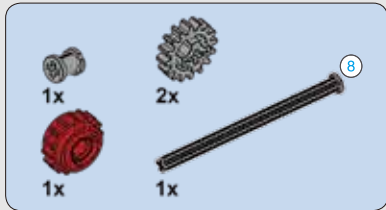
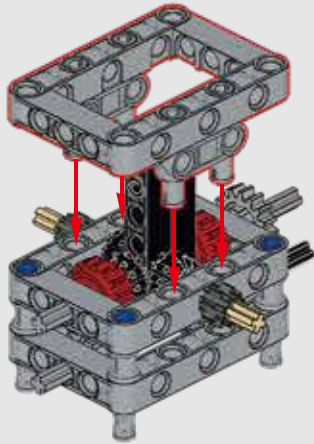

174

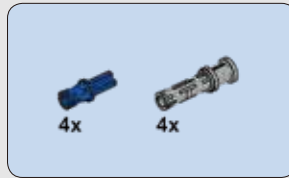
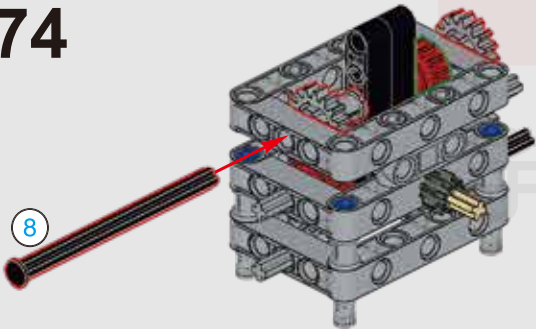

175

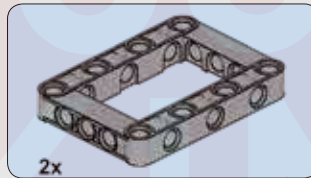
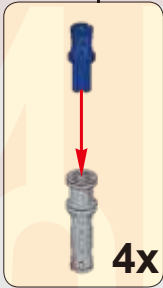

176

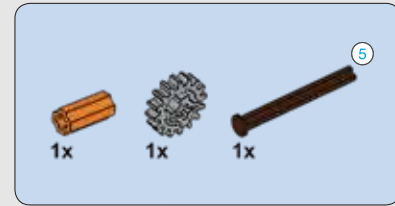
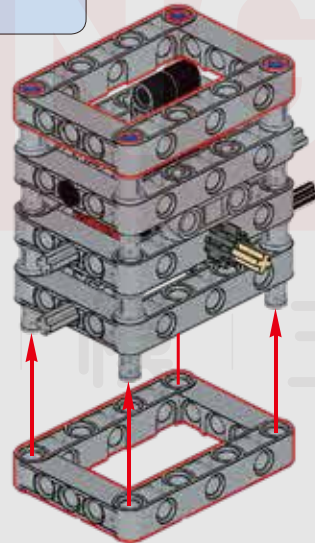

177

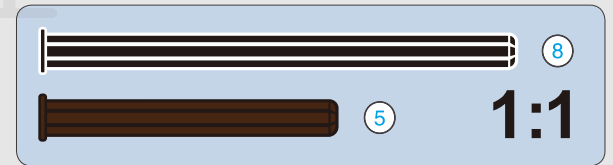
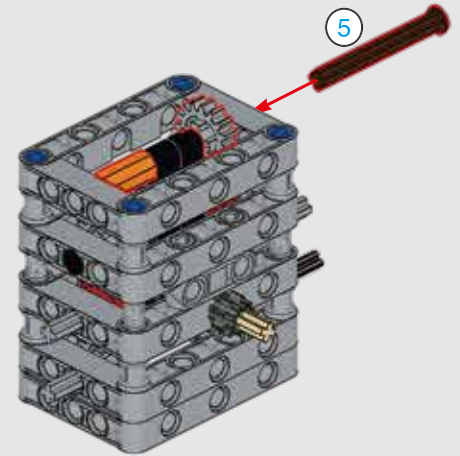

1:1

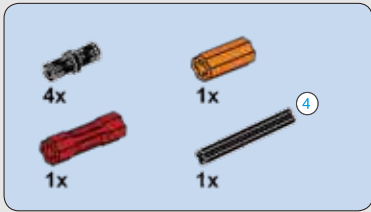

178

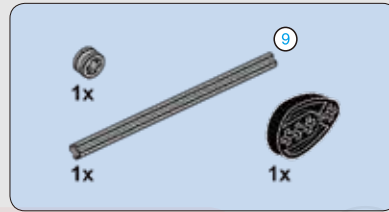
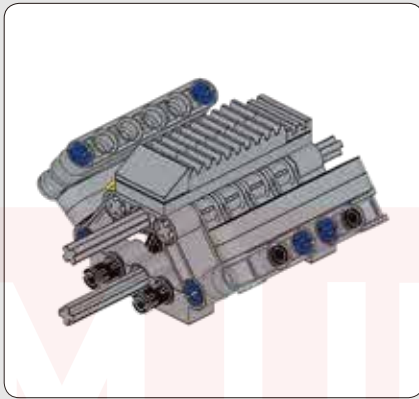
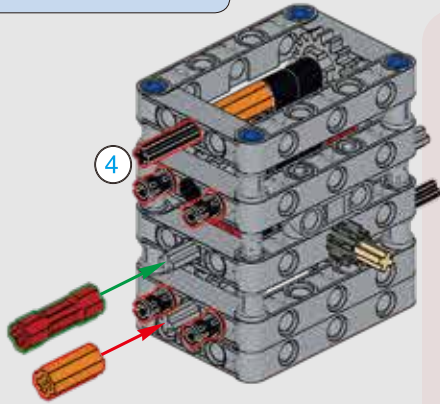

179



180



181

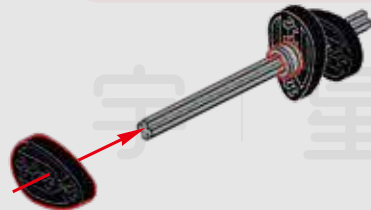

182

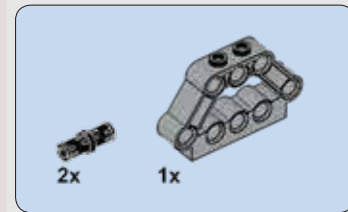

183

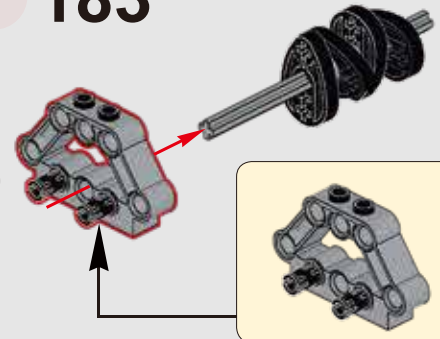

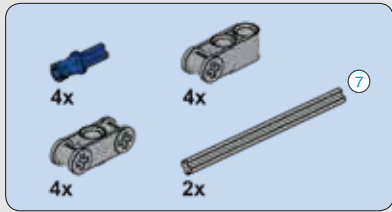

184

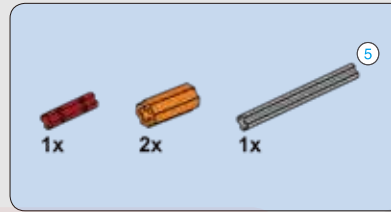
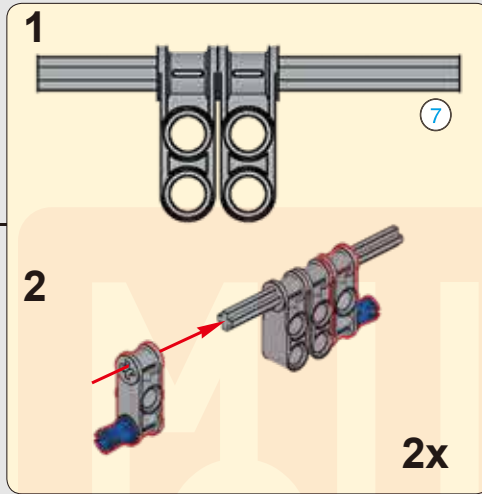
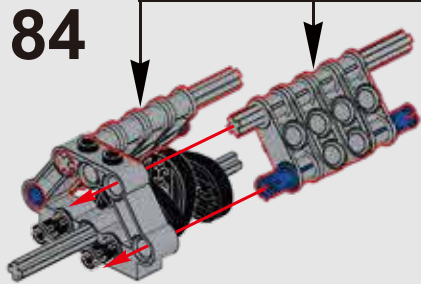

185

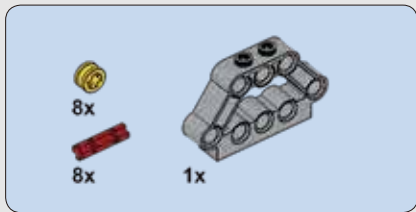
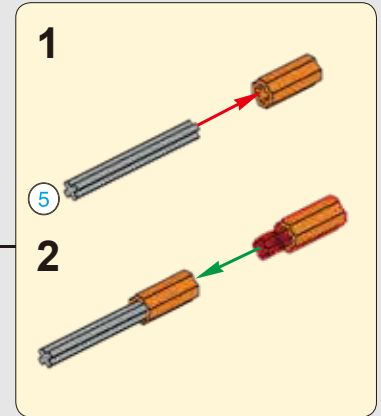
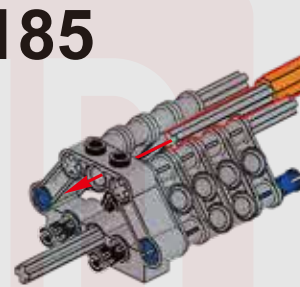

186

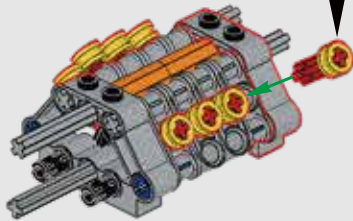

187

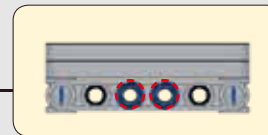
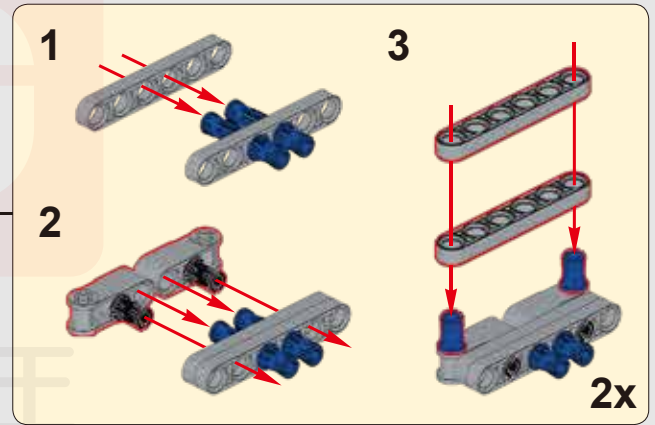
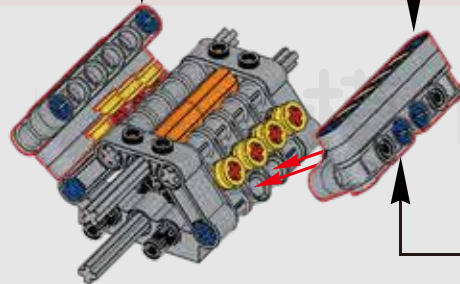

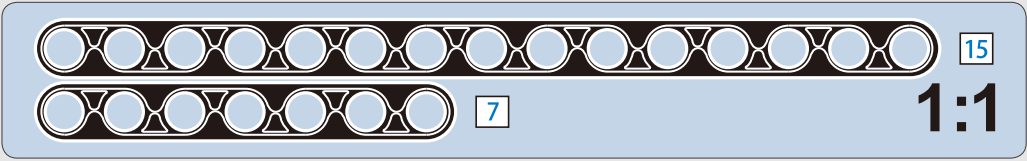
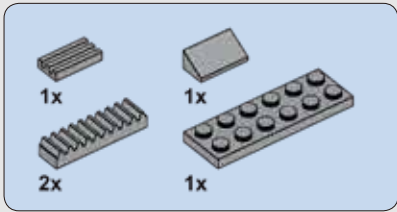

188

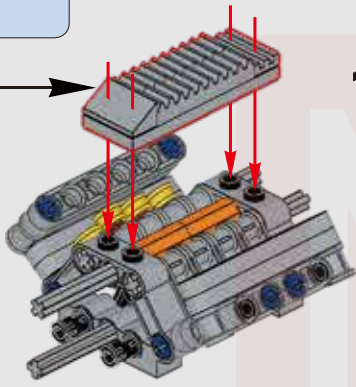
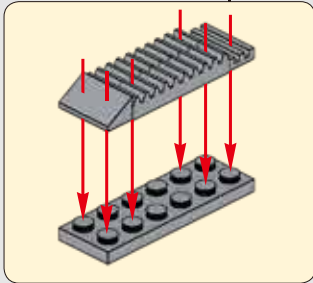

189

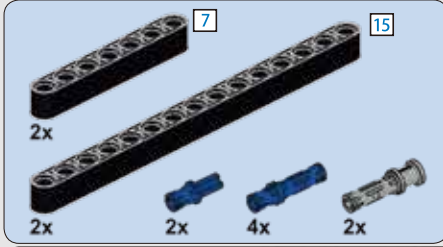
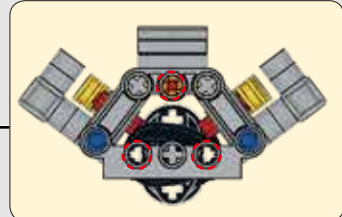
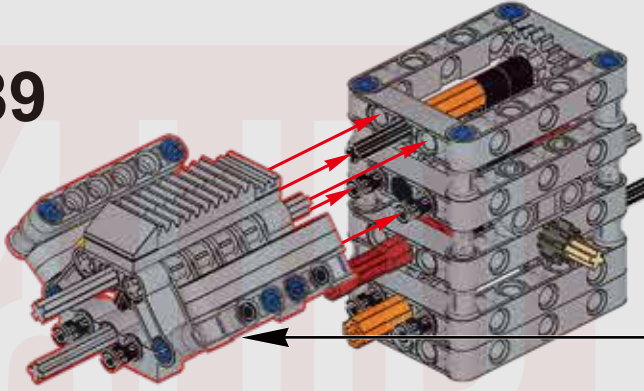

190

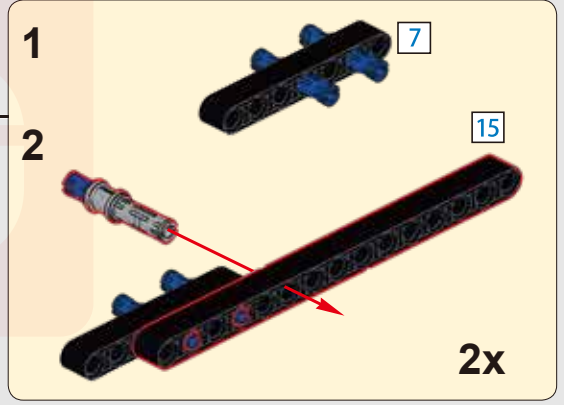
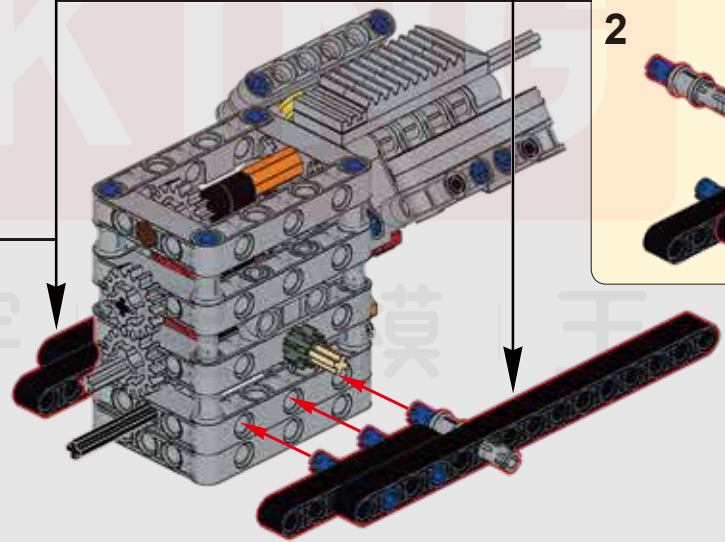
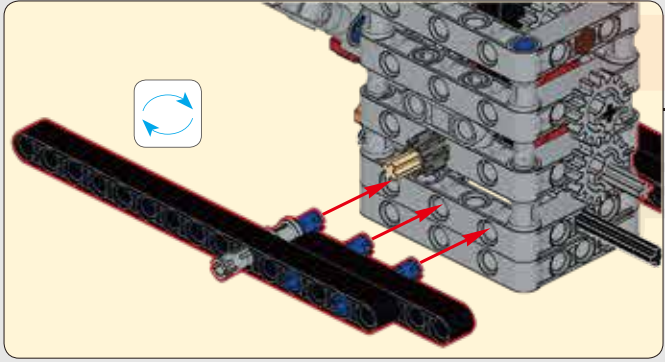
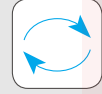

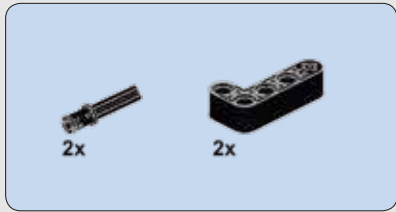

191

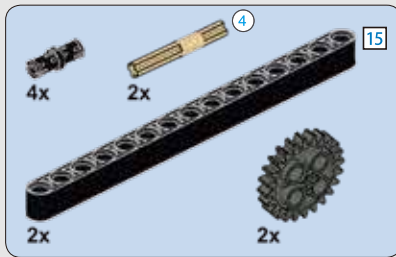
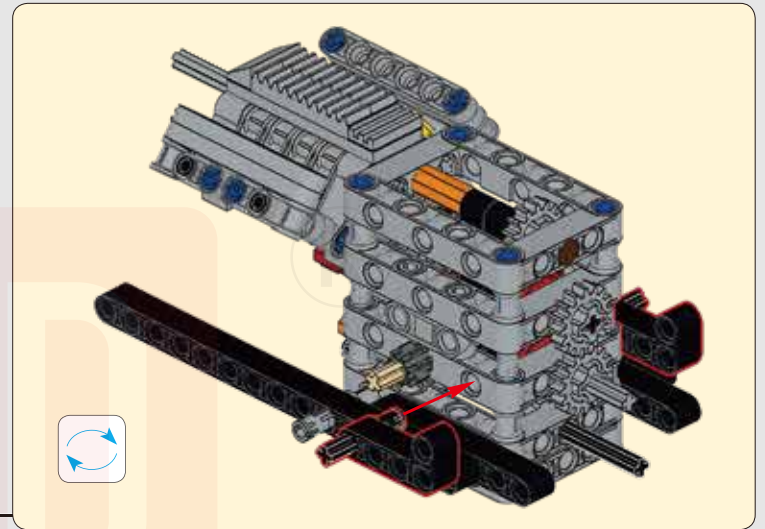
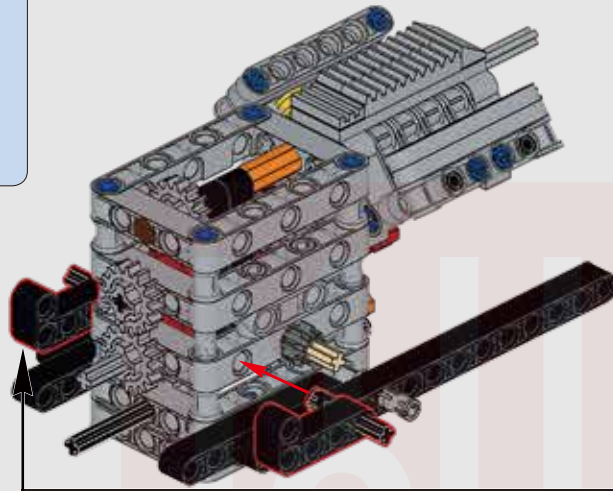

192

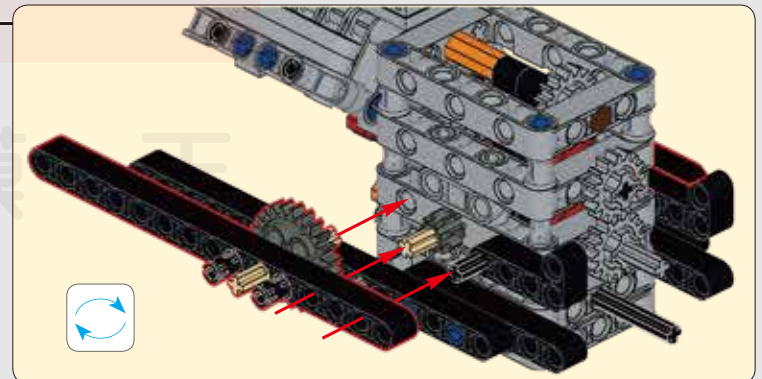
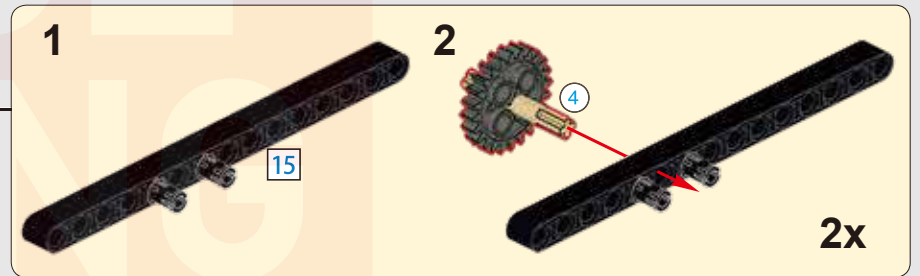
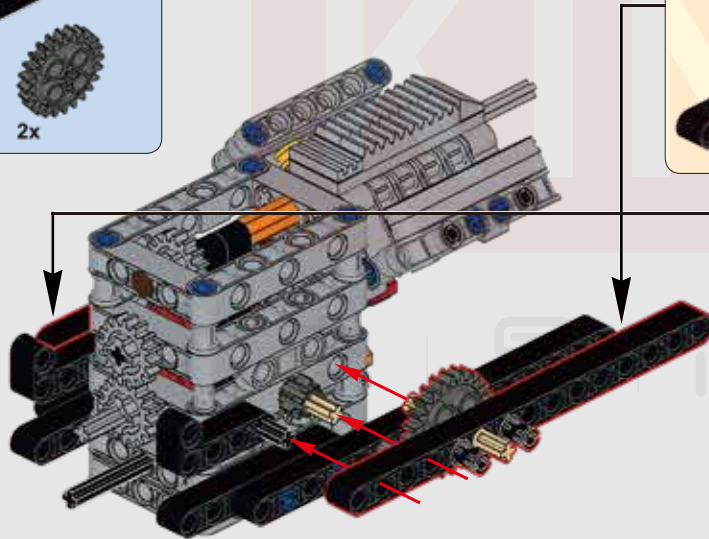

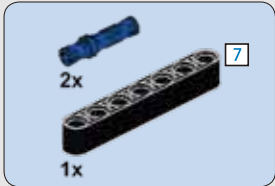

193



7



15

1:1

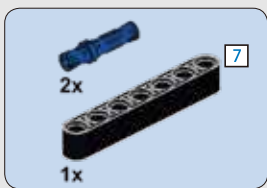

196

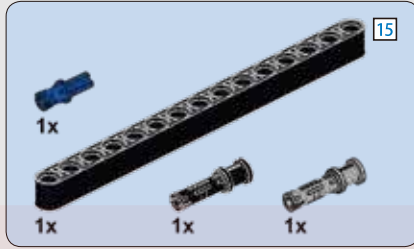

194

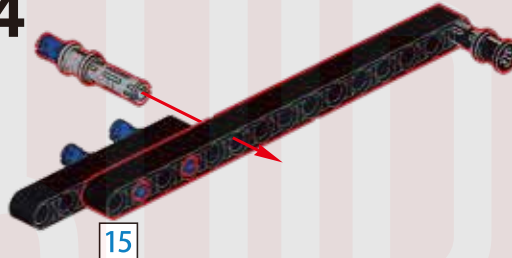

15

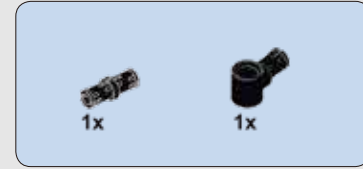

195

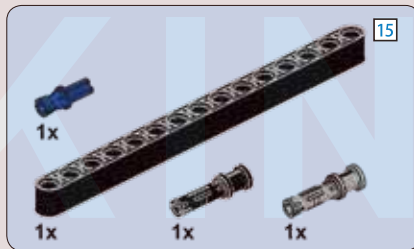

197

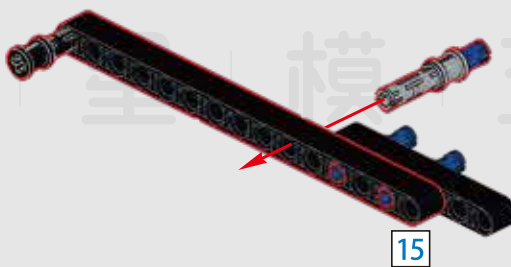

15

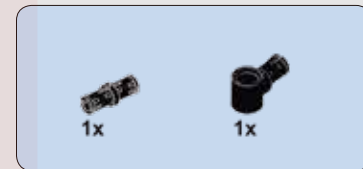

198

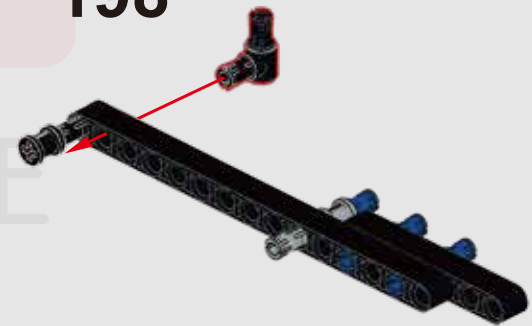

199

 5 1:1

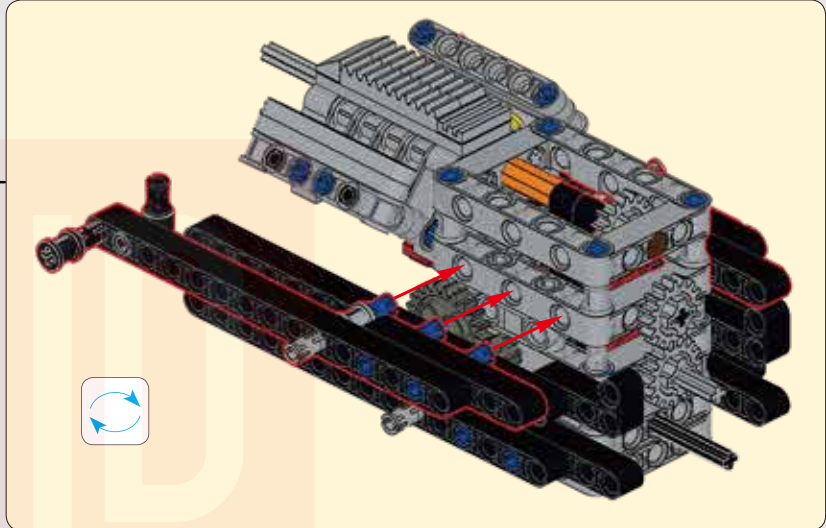
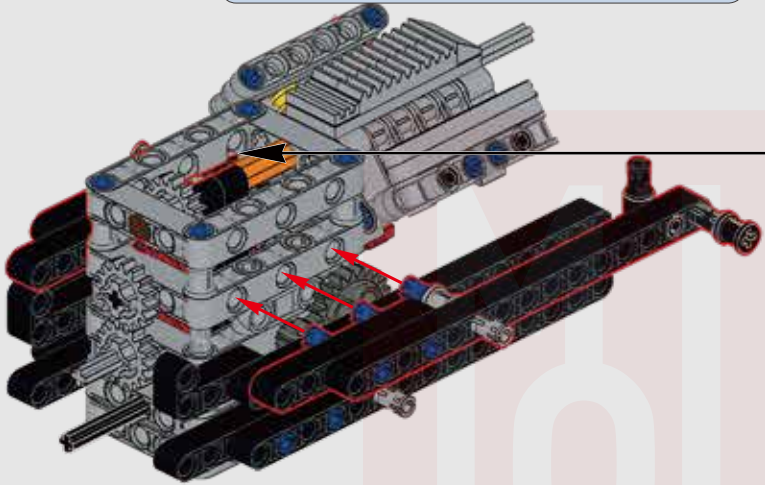

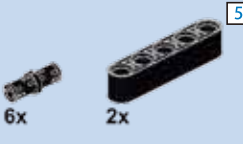
 6x 2x 5

200

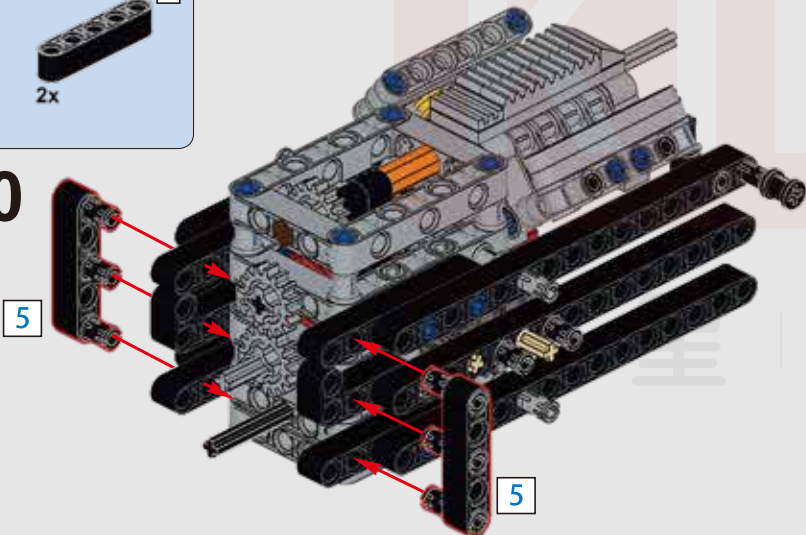

 6x

201

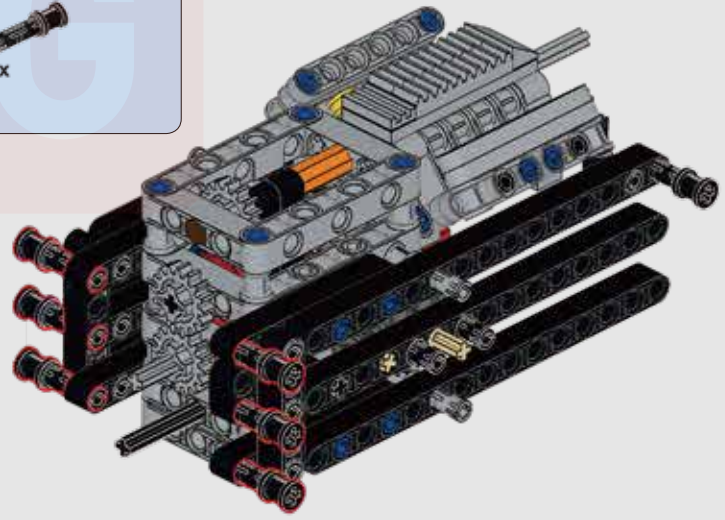

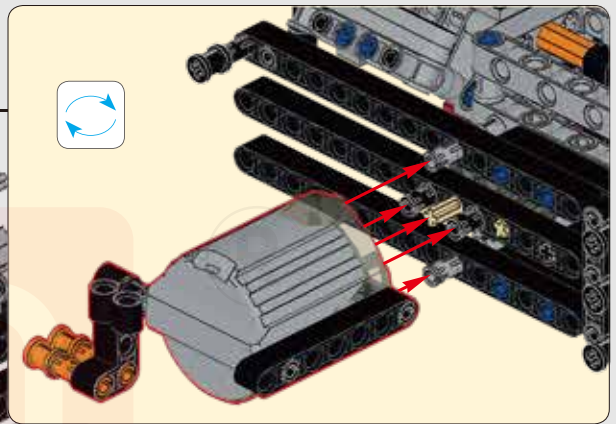
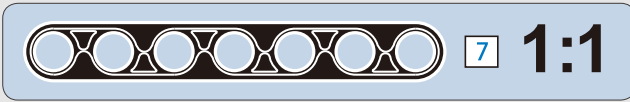
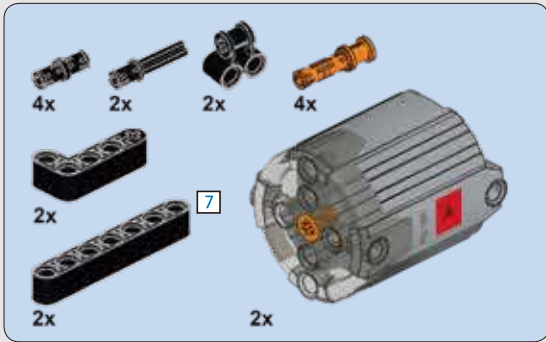

202

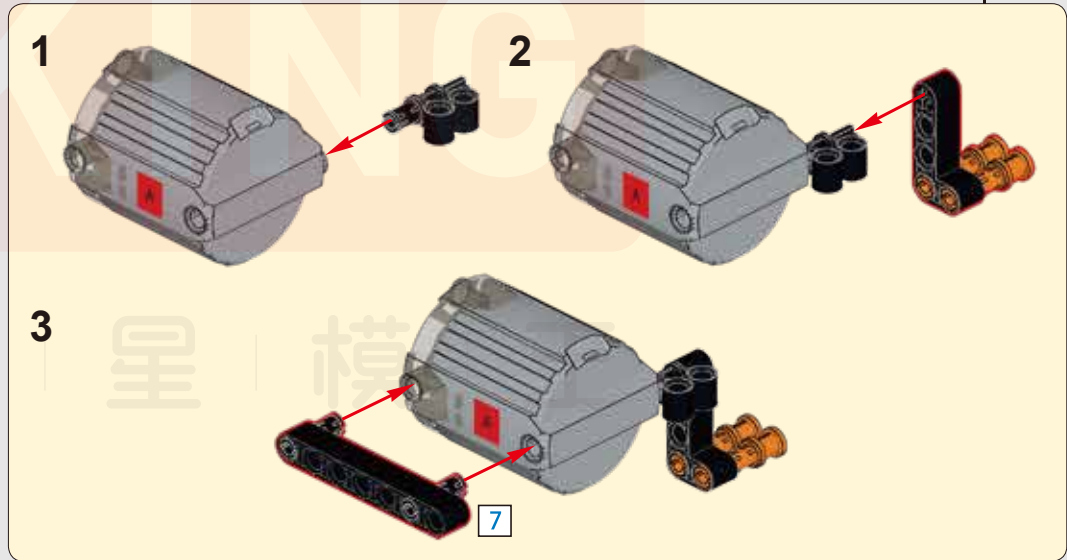
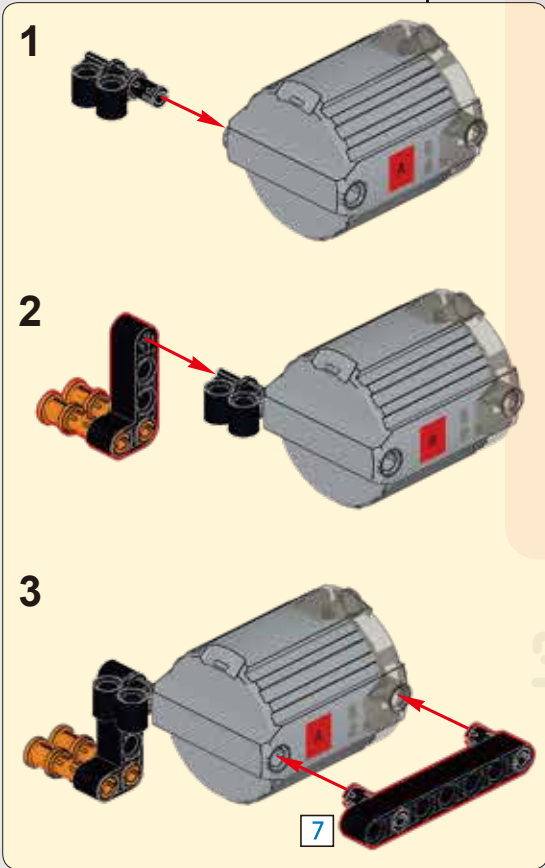

203

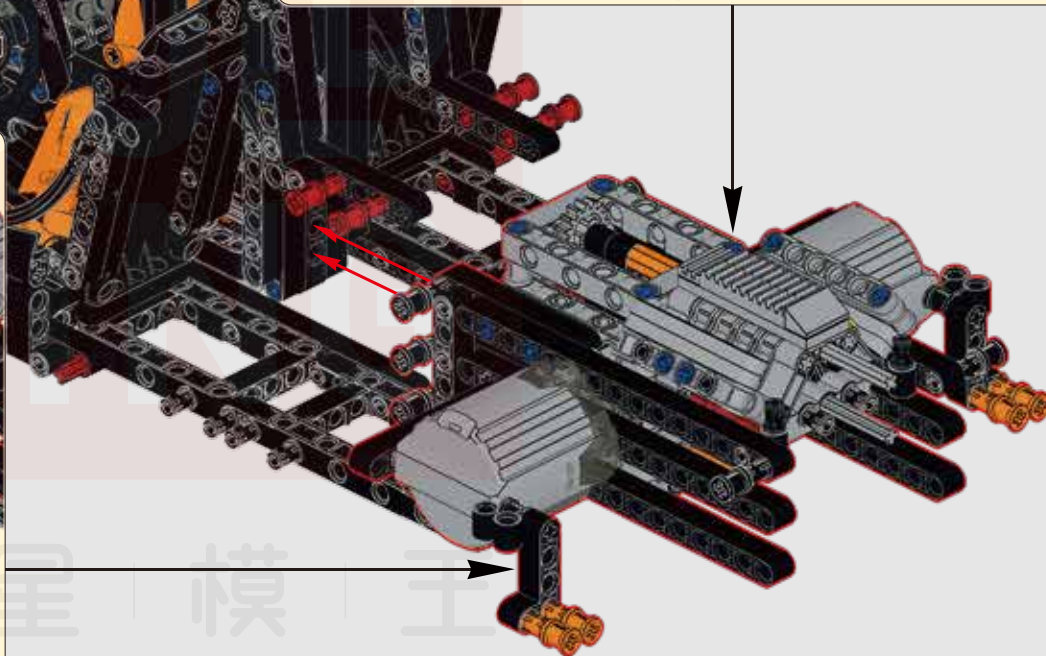
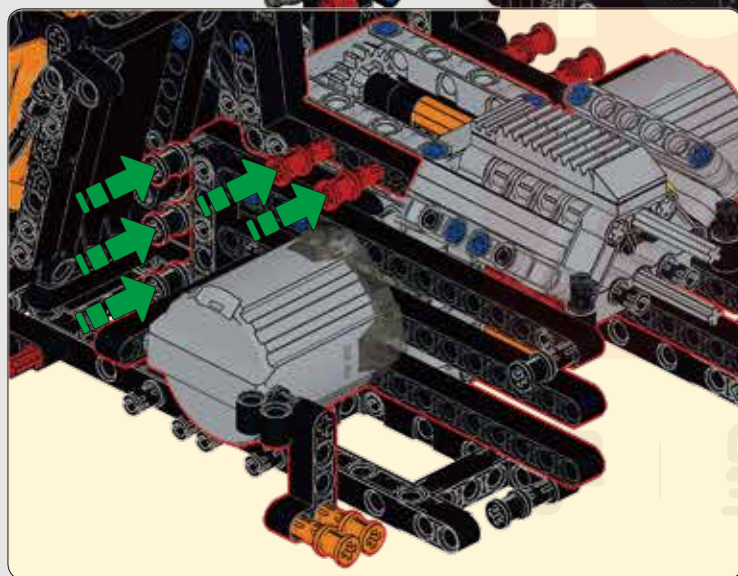
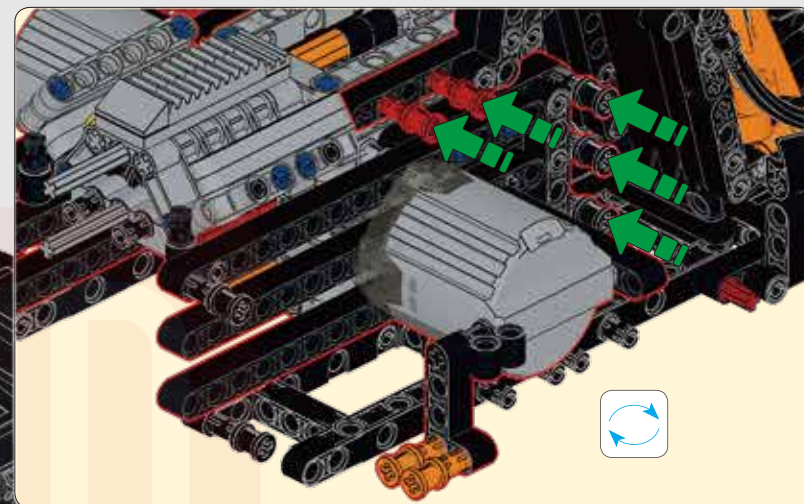
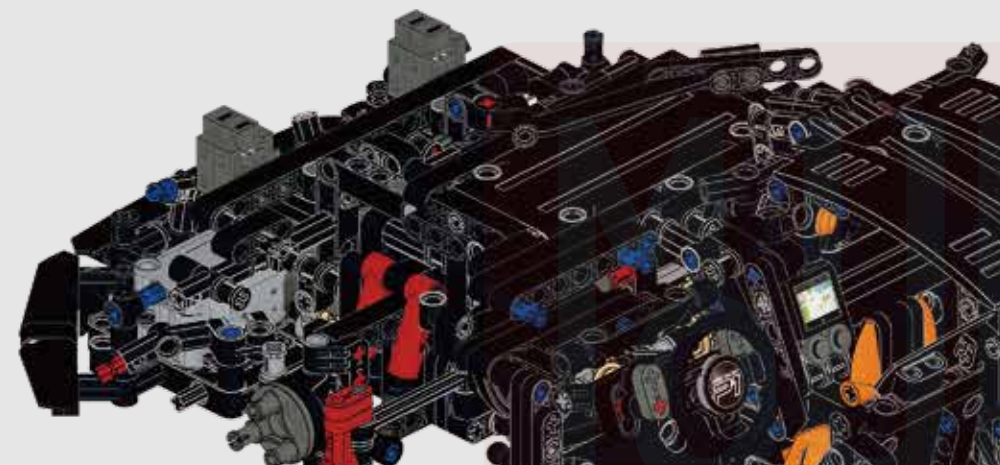

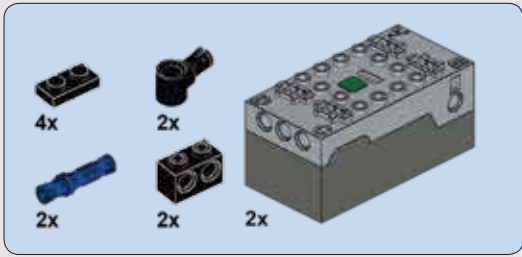

204

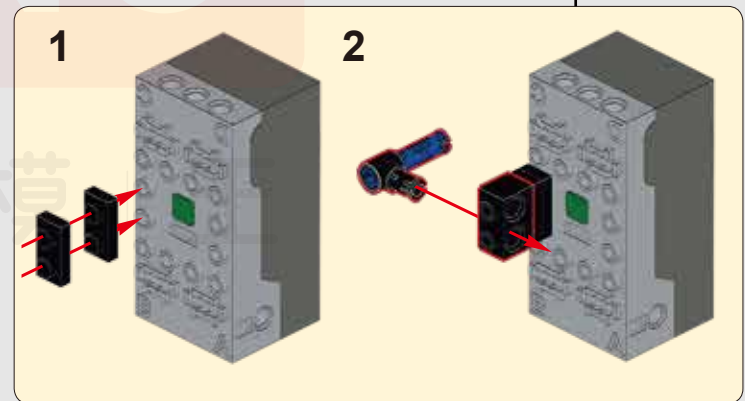
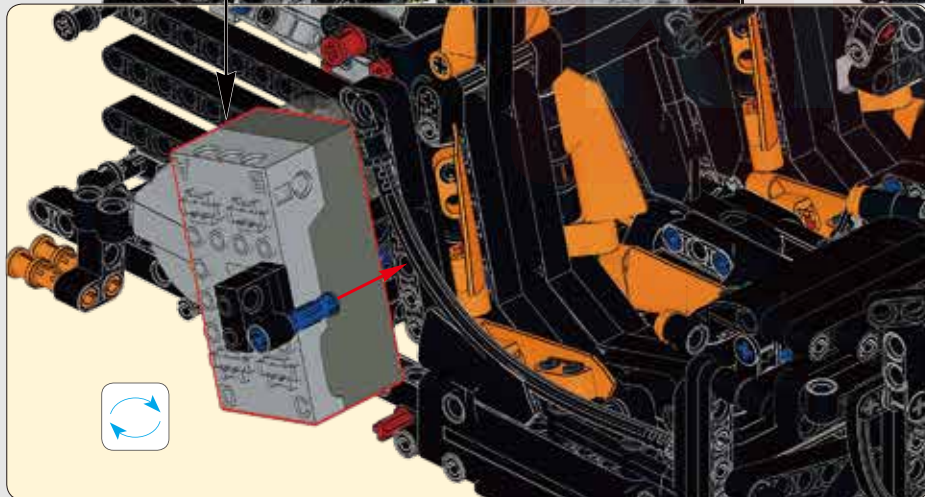
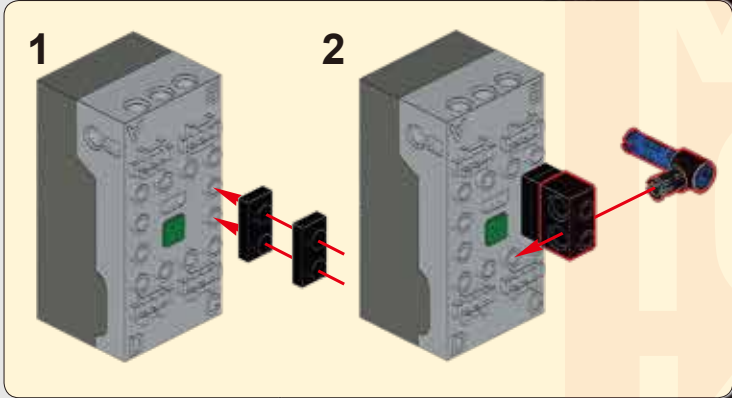

205

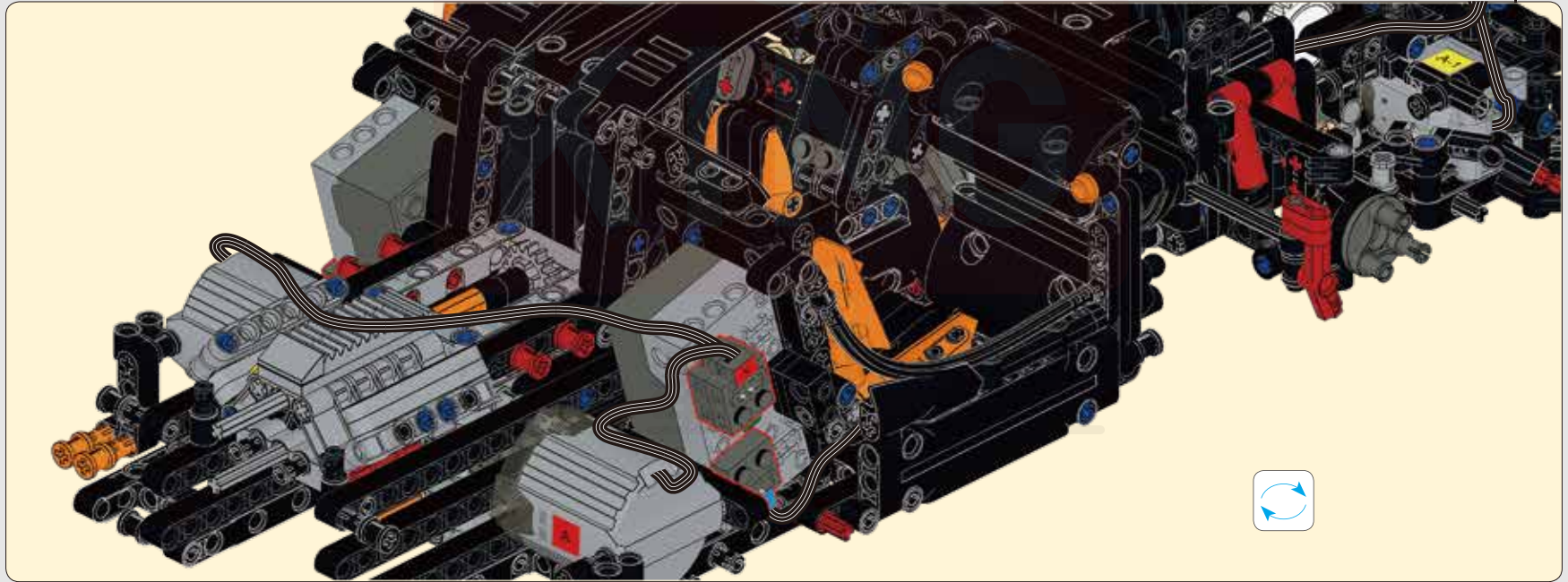
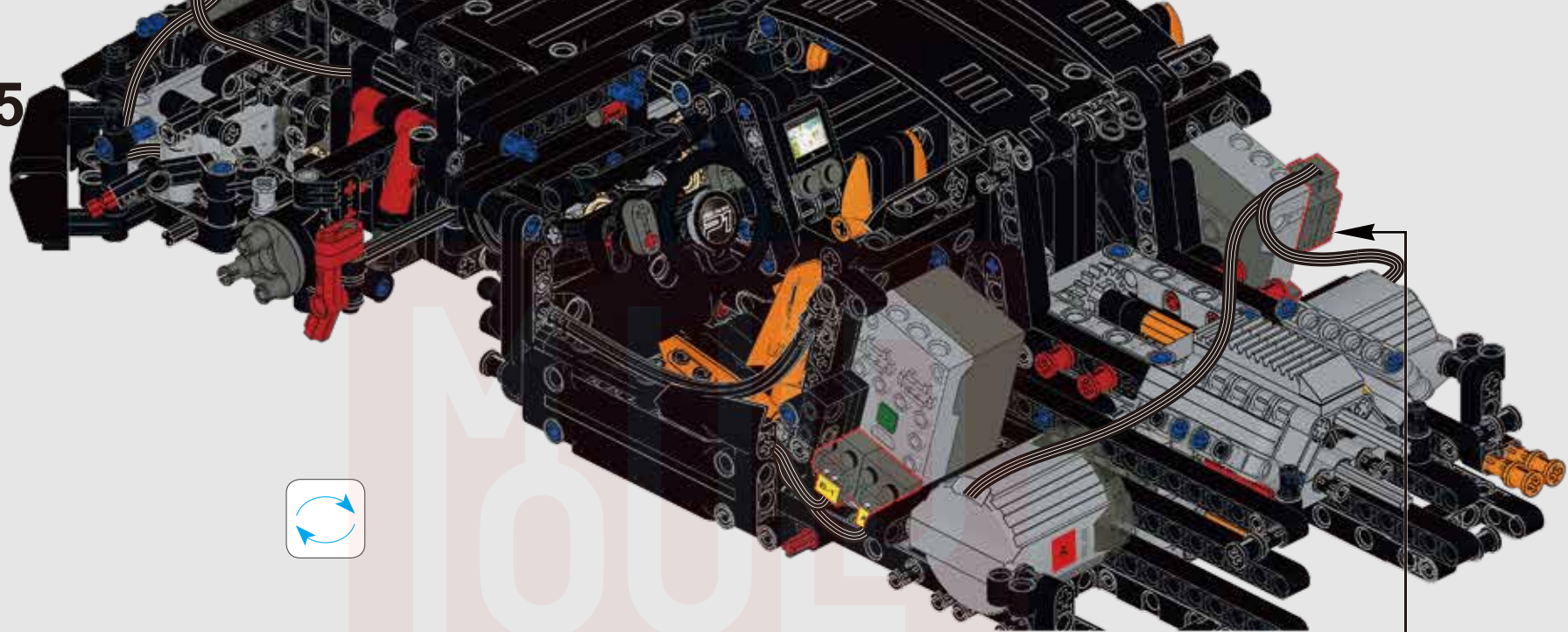

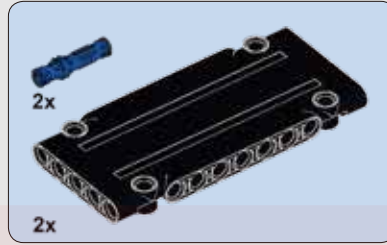
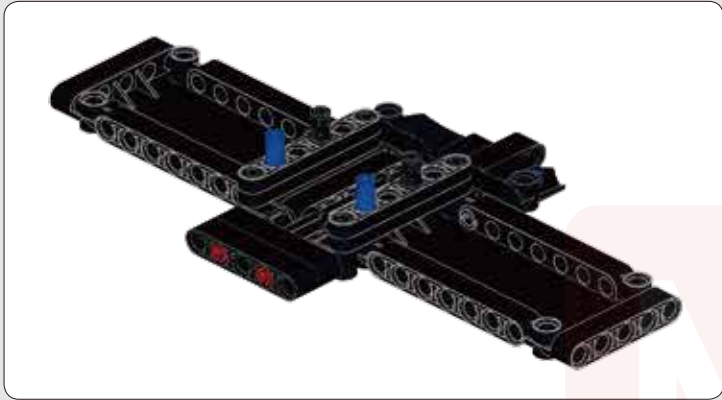

207

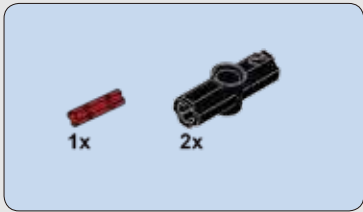
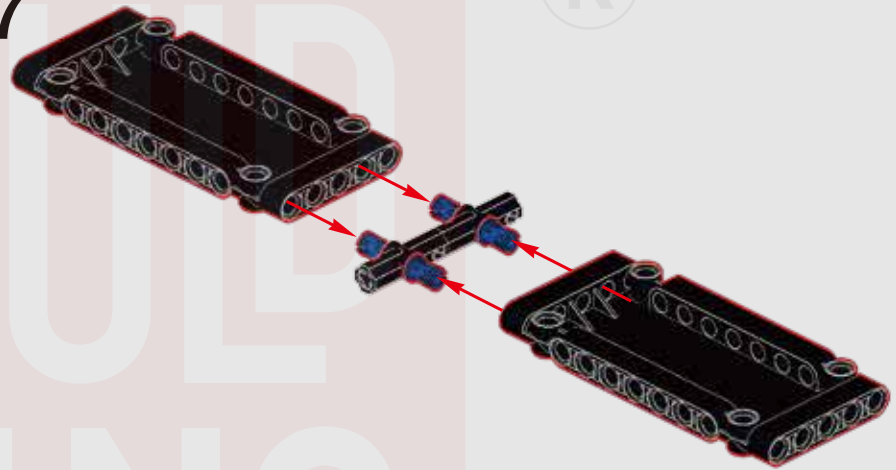

206

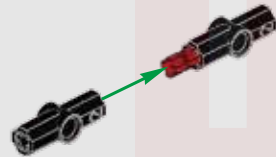

208

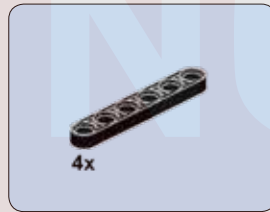
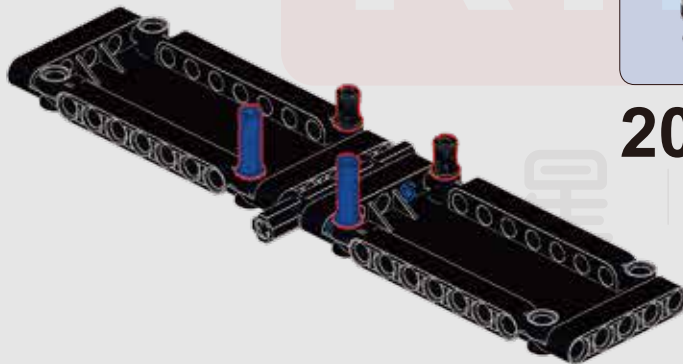

209

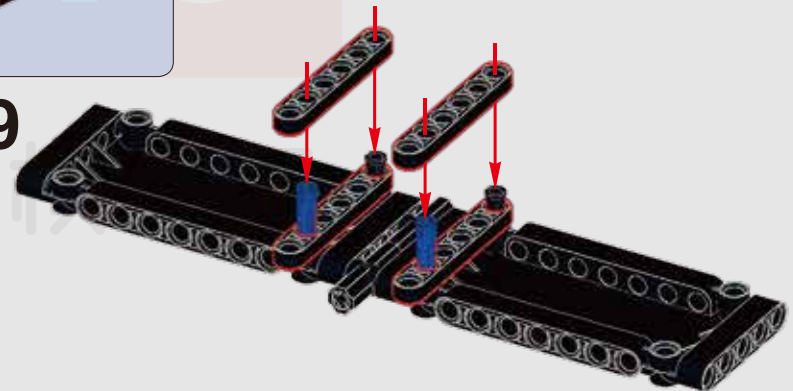

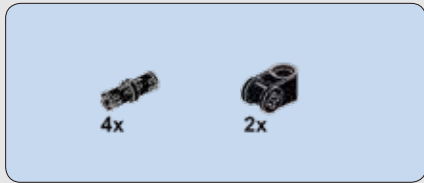

210

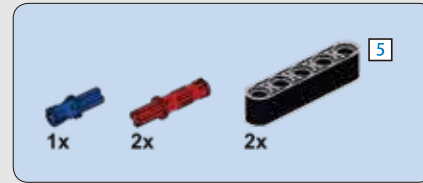
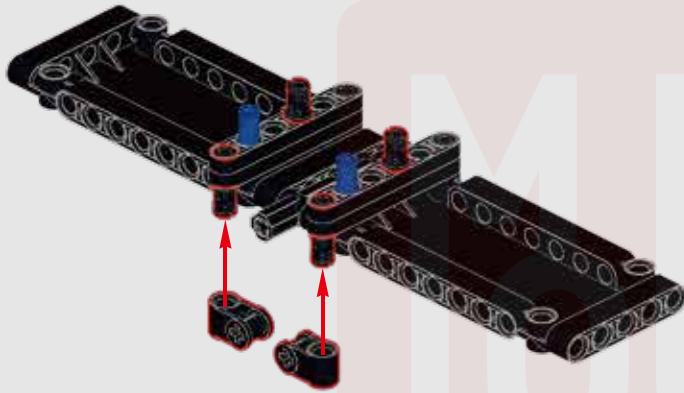

211

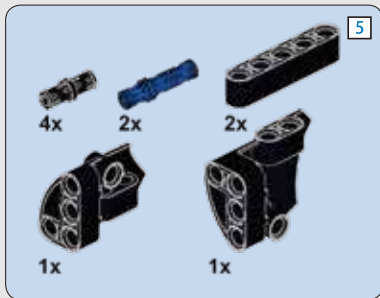
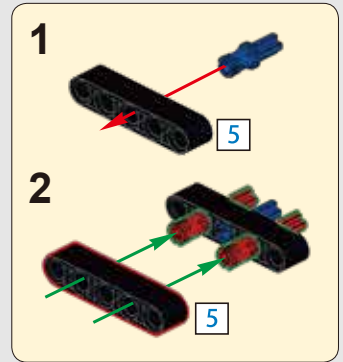
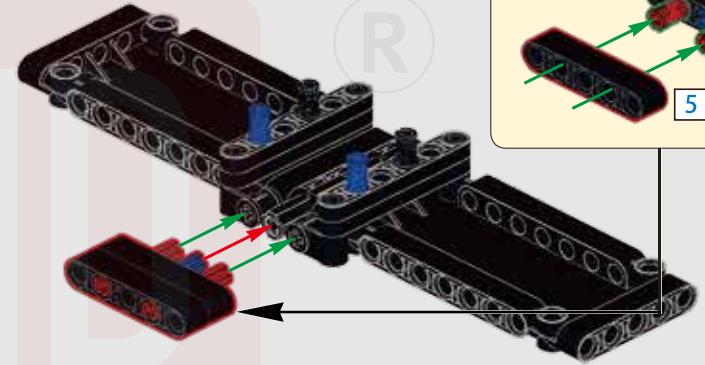

212

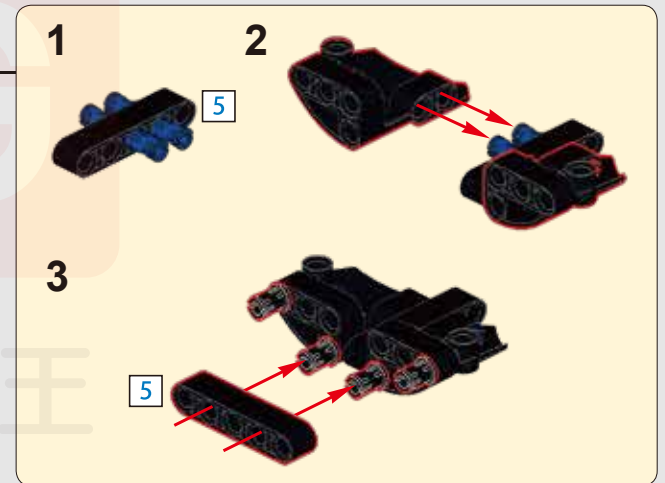
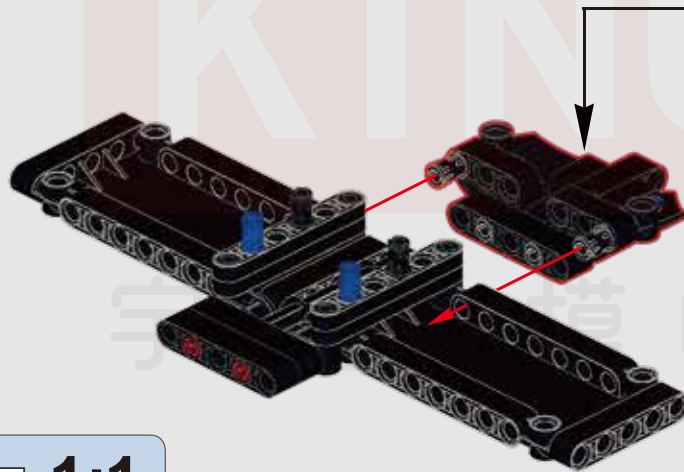

213

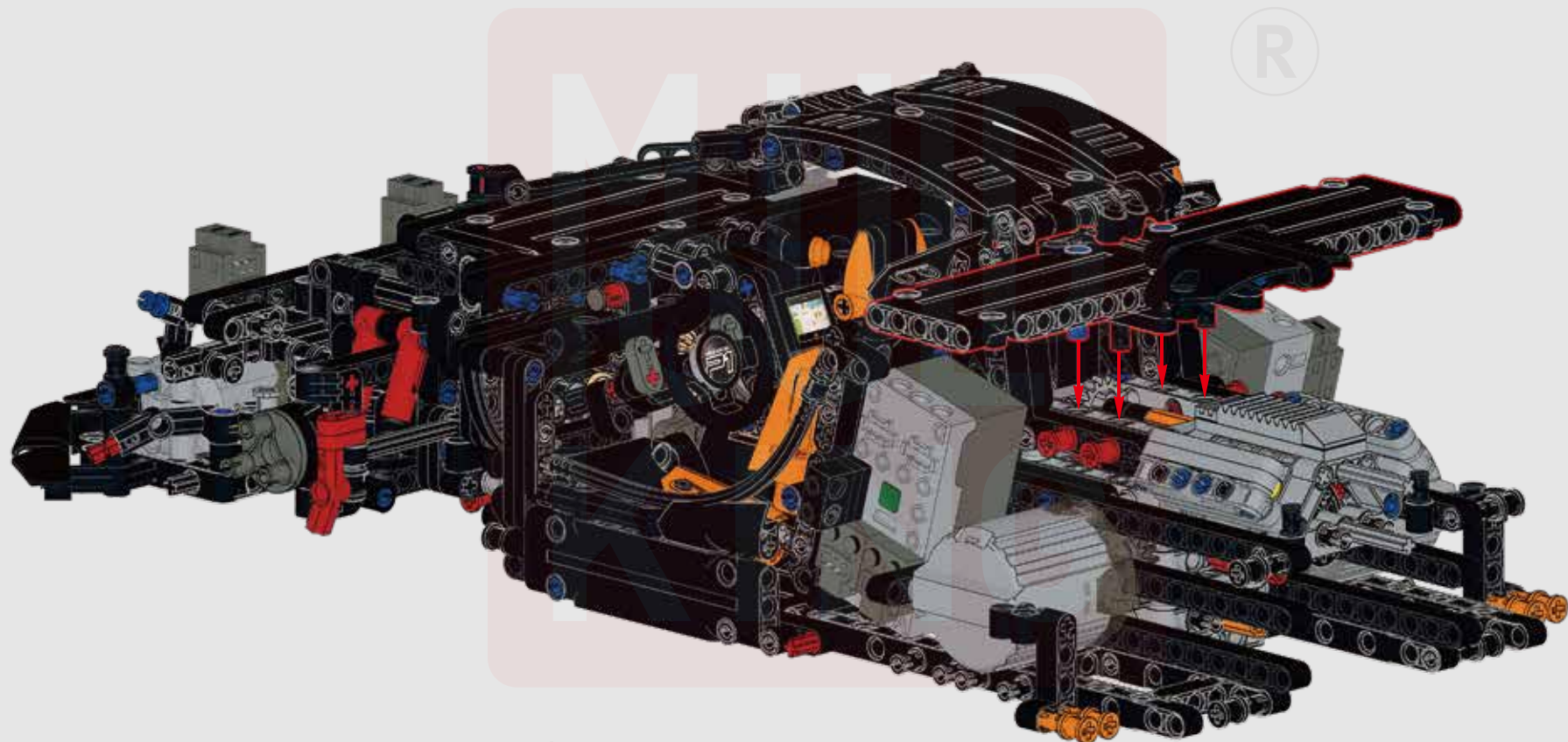

宇 | 星 | 模 | 王



214

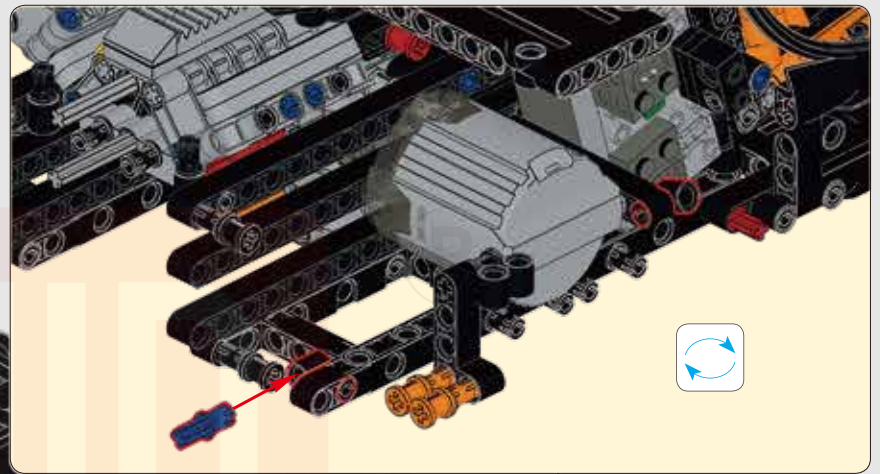
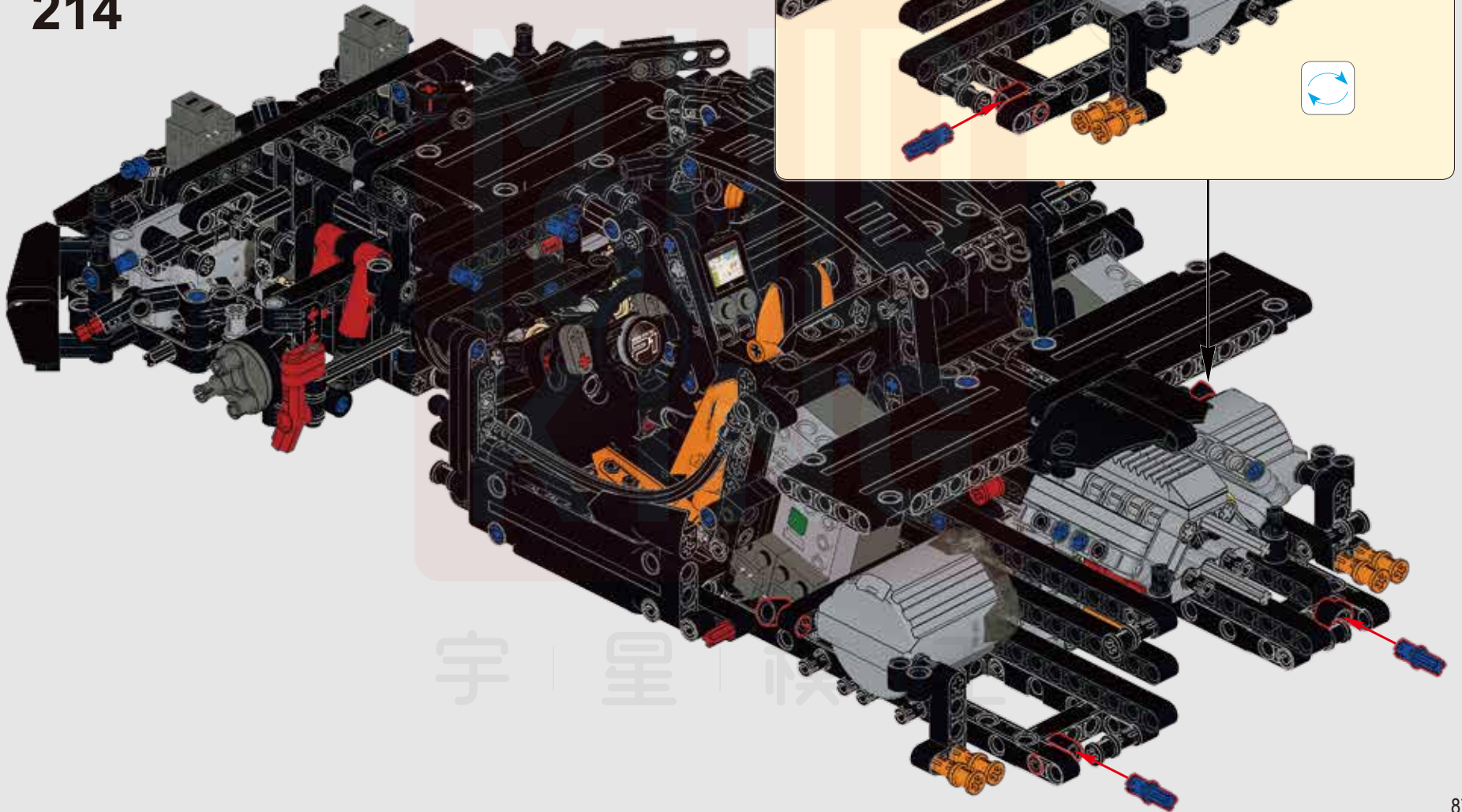

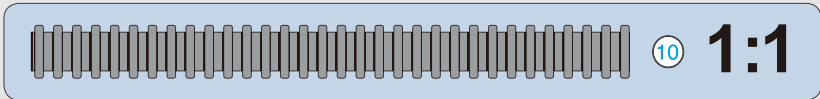
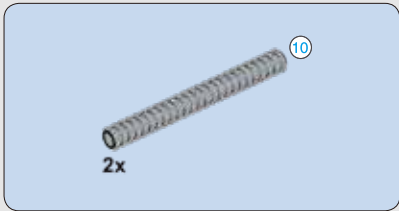

215

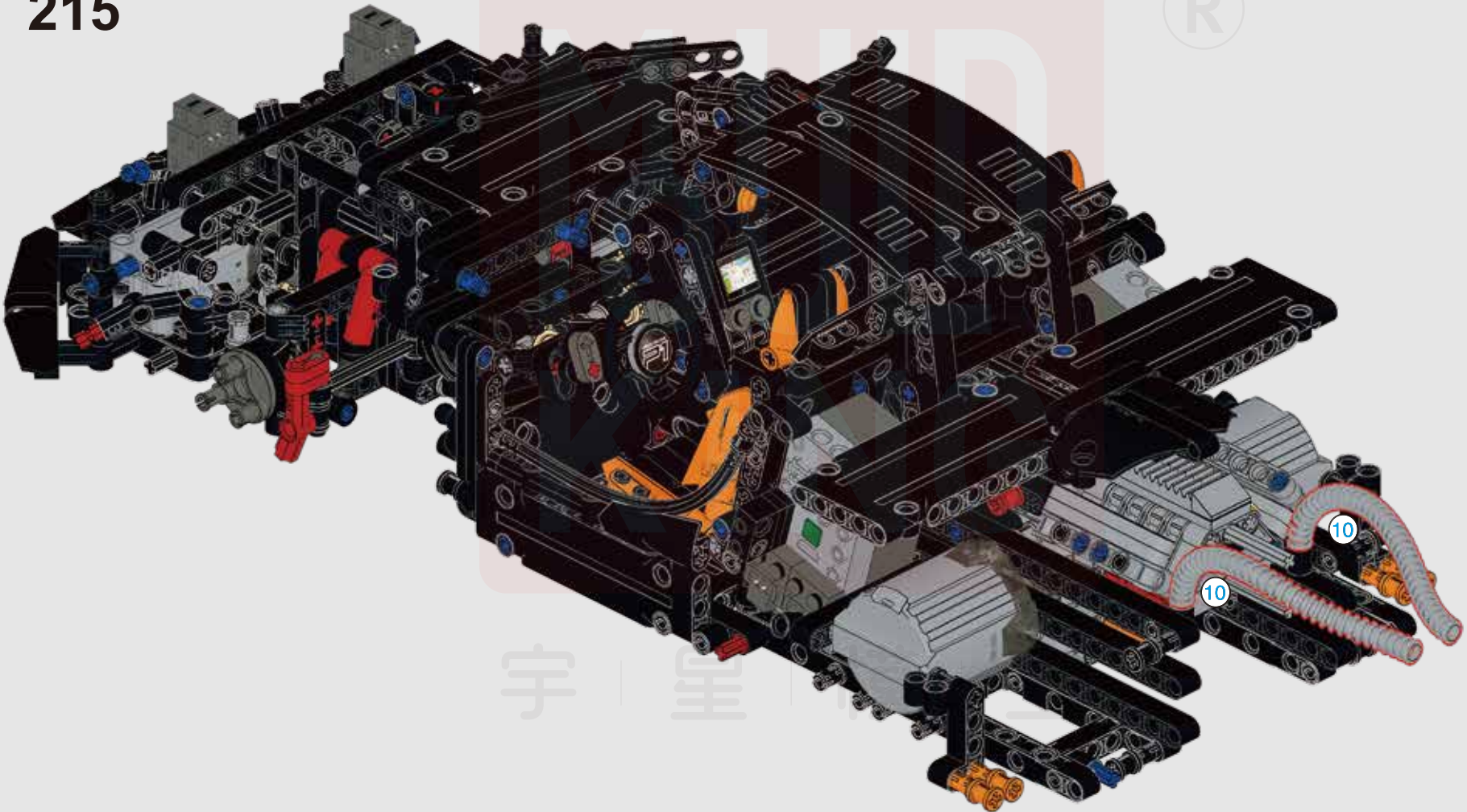

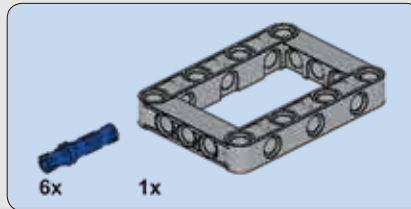
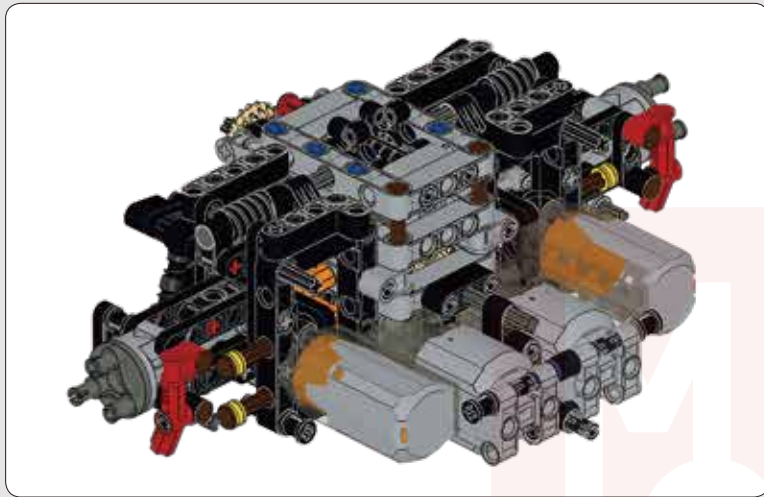

216

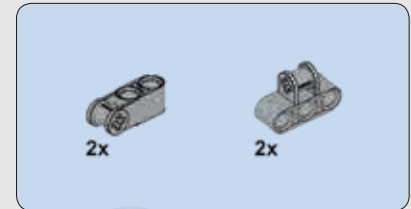
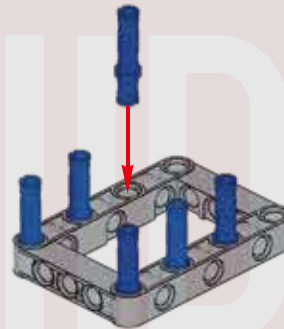

217

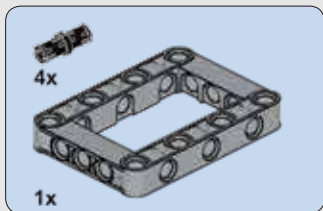
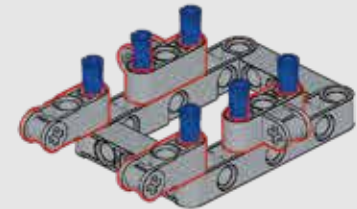

218

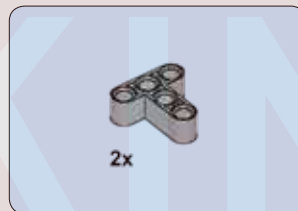
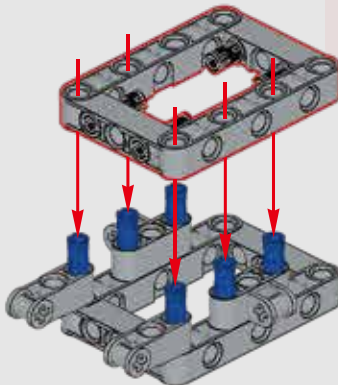

219

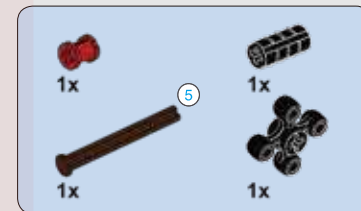
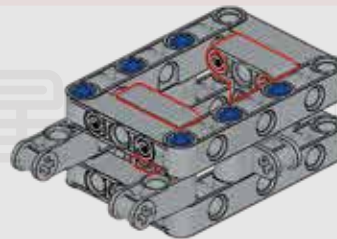

220

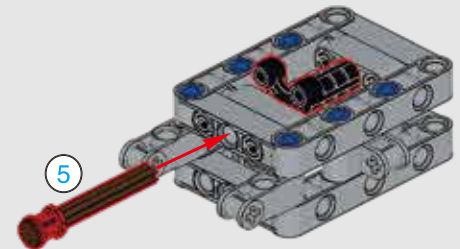

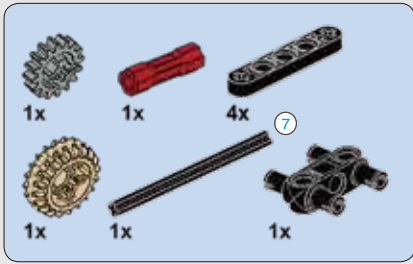

221

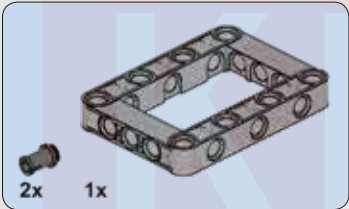
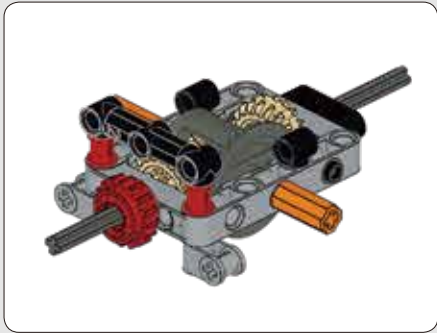
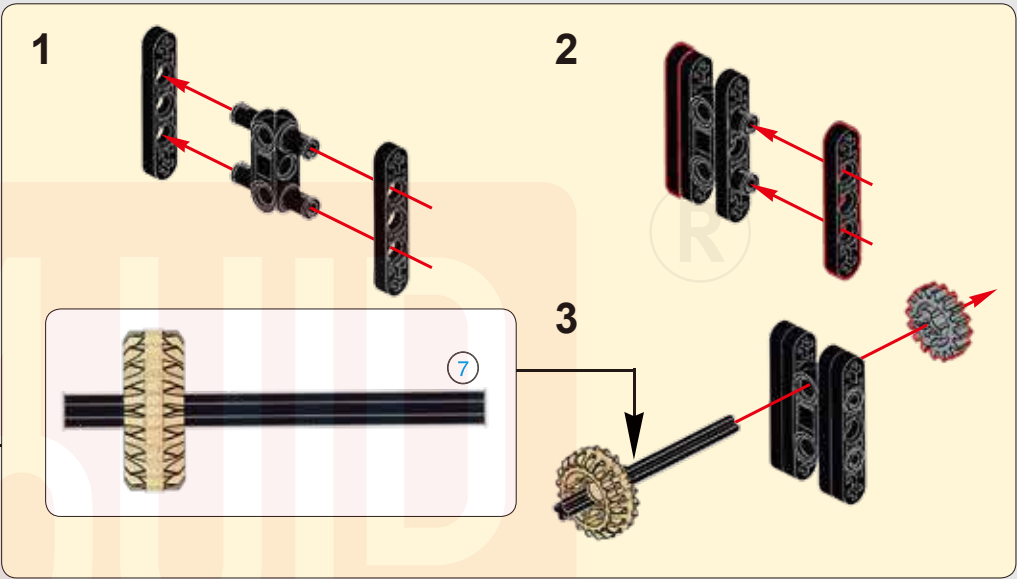
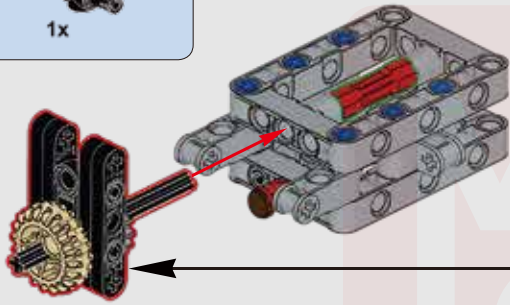

222

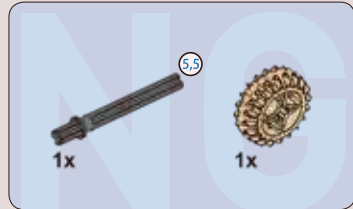
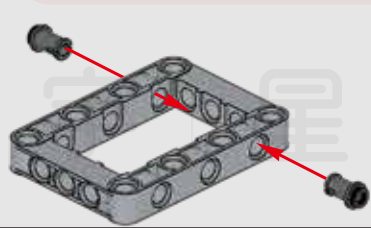

223

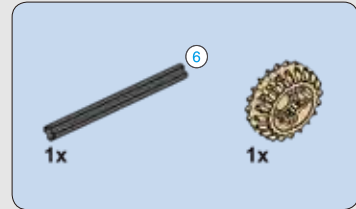
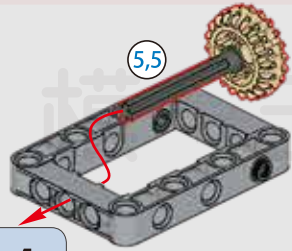

224

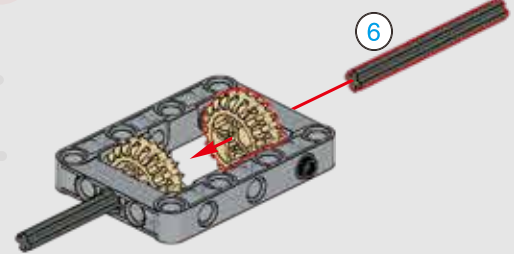

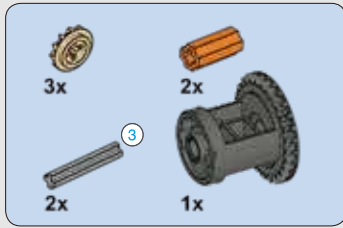

225

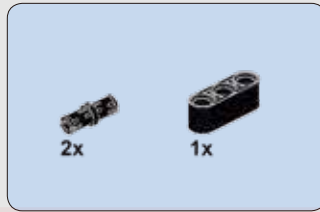
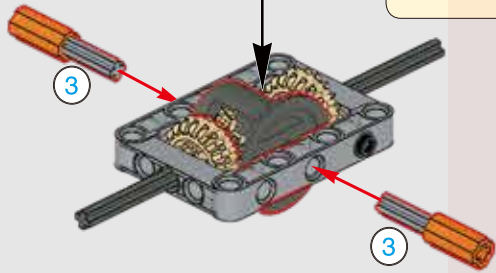

226

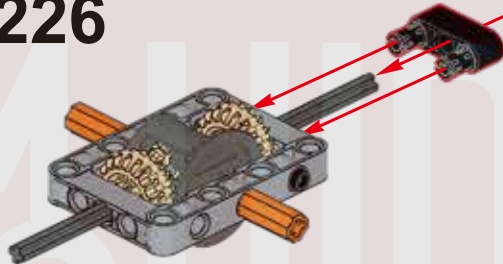

227

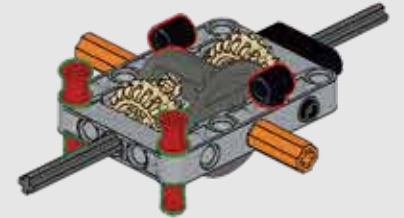

228

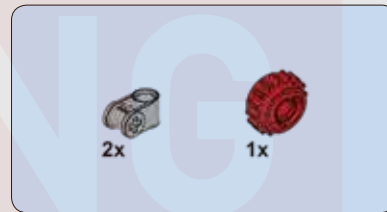
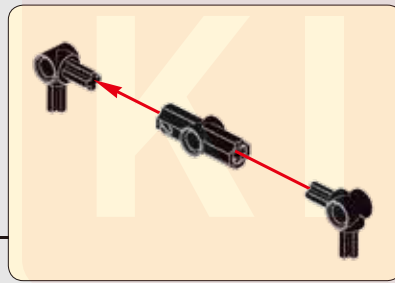
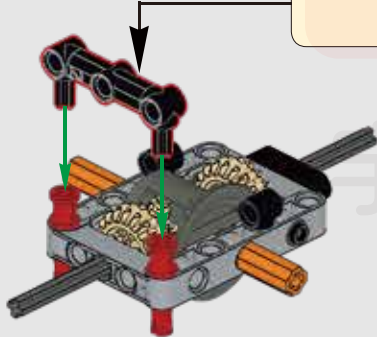

229

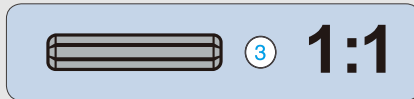
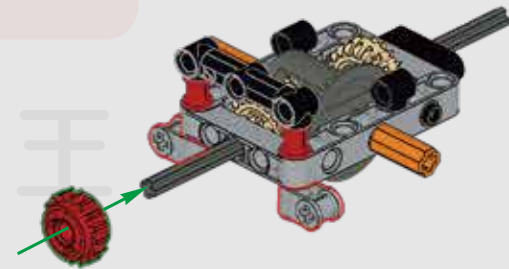

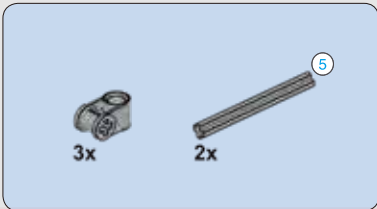
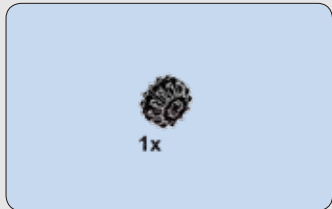

230

231

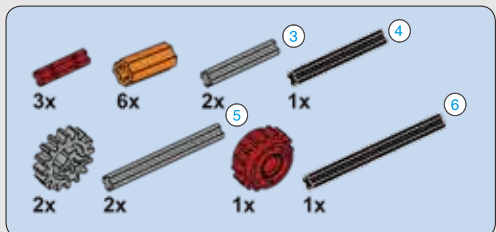
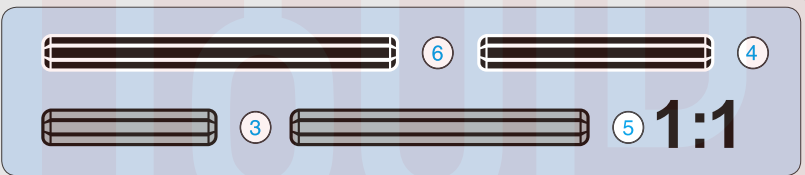
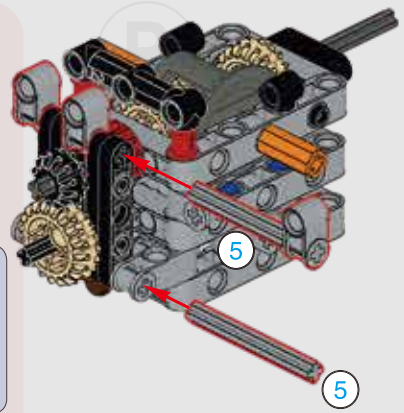
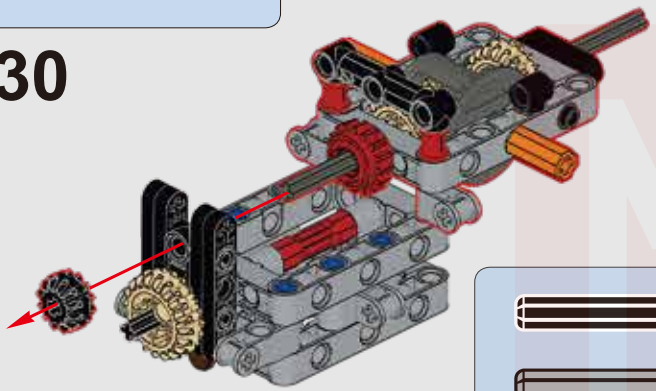

232

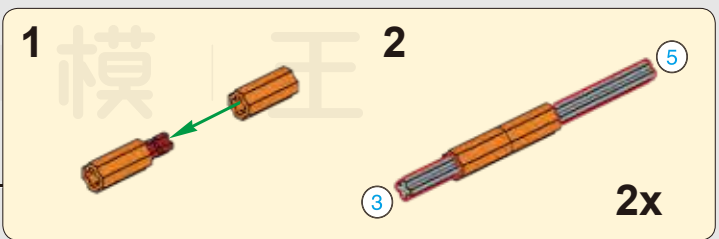
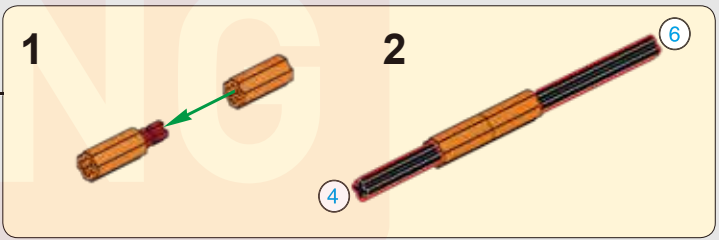
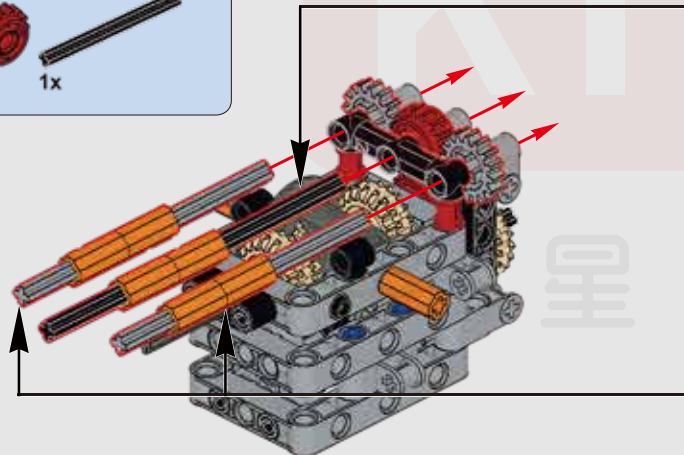

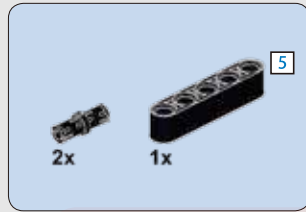

233

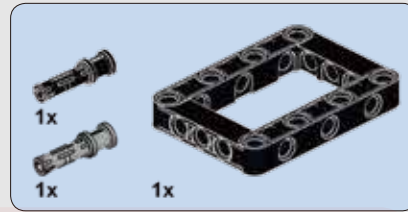

234

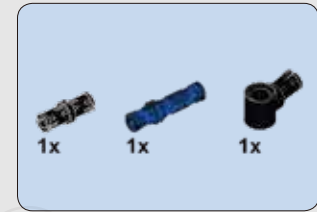

235

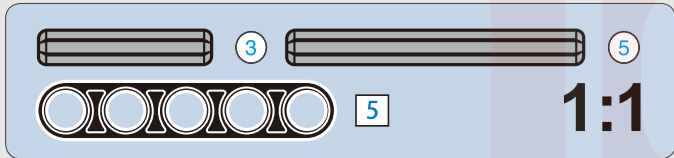

1:1

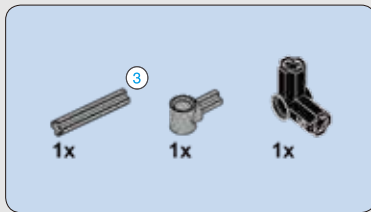
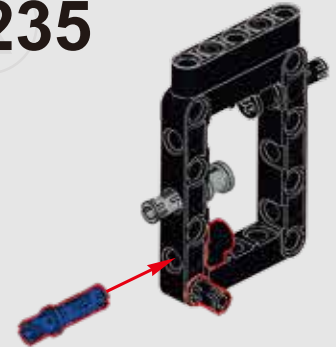
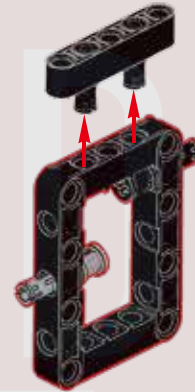

236

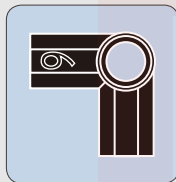

237

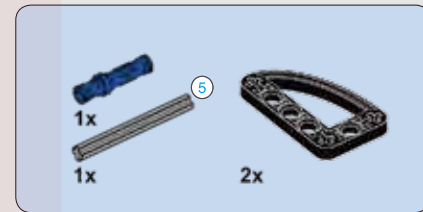

238

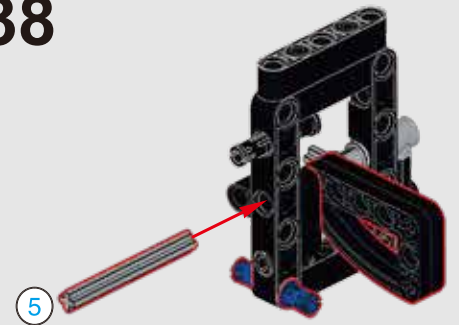
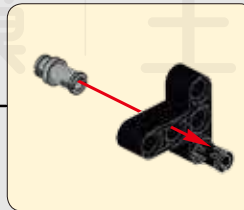
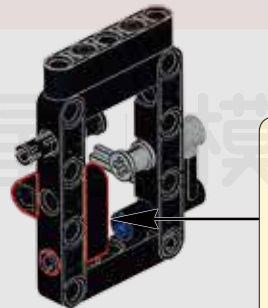
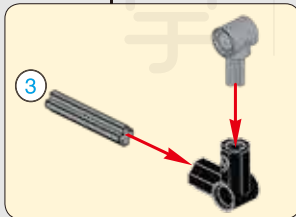
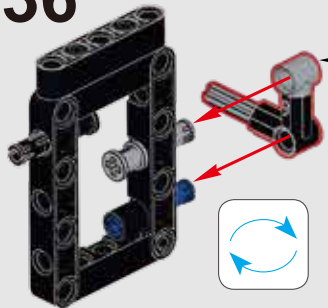

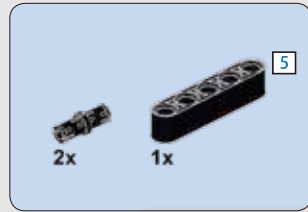

239

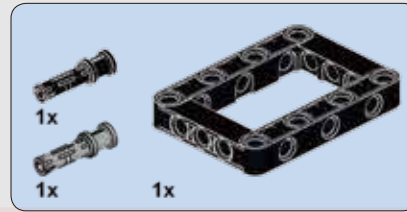

240

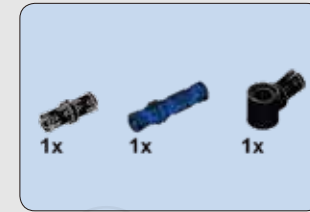

241

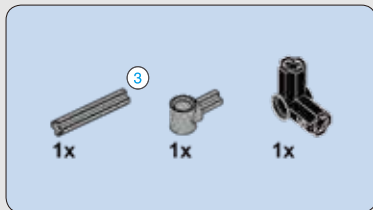
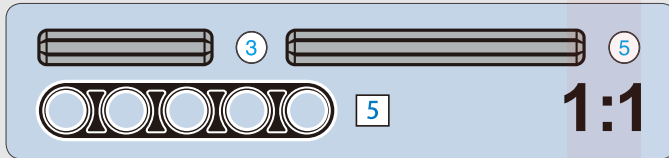

242

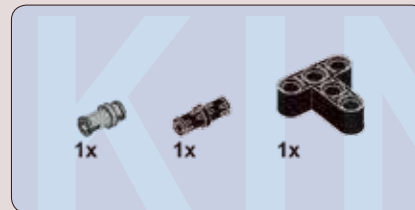
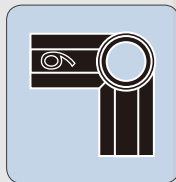

243

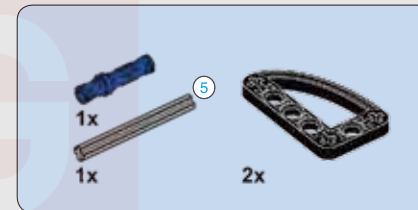

244

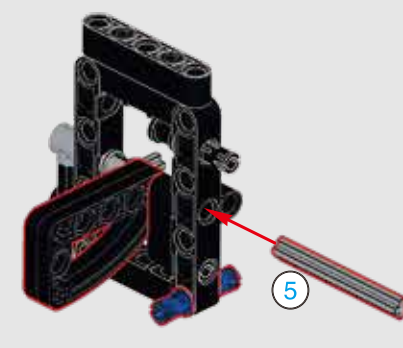
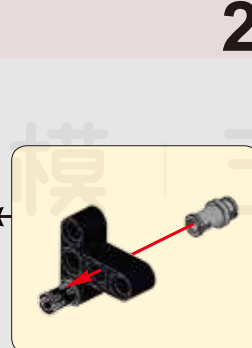
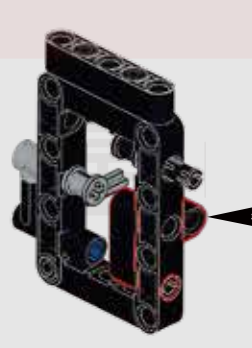
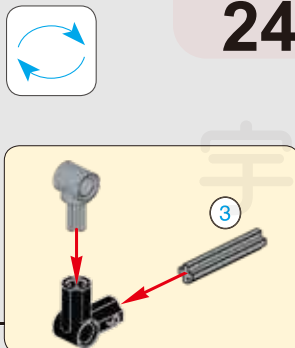
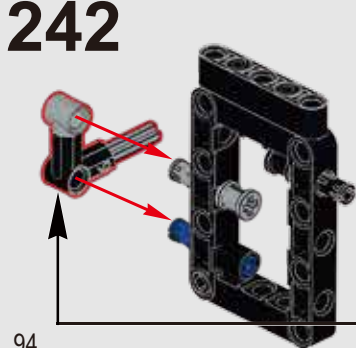

245

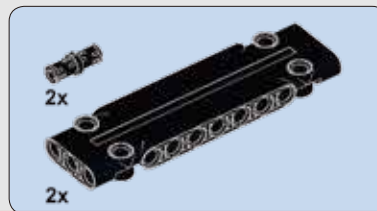
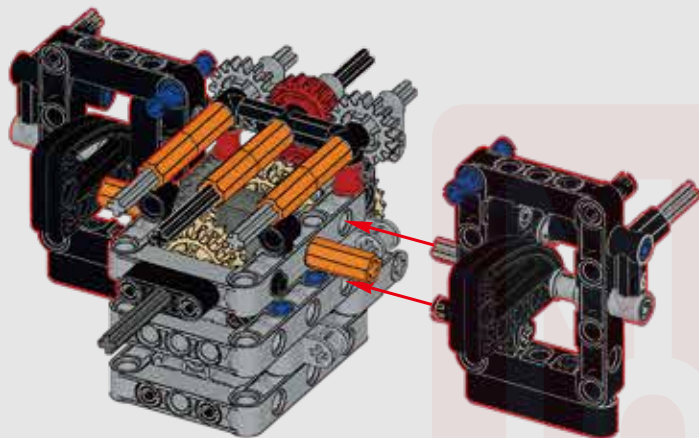

246

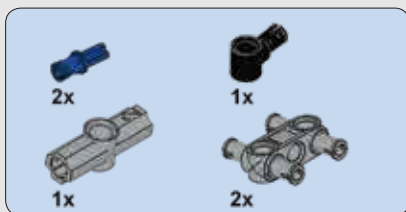
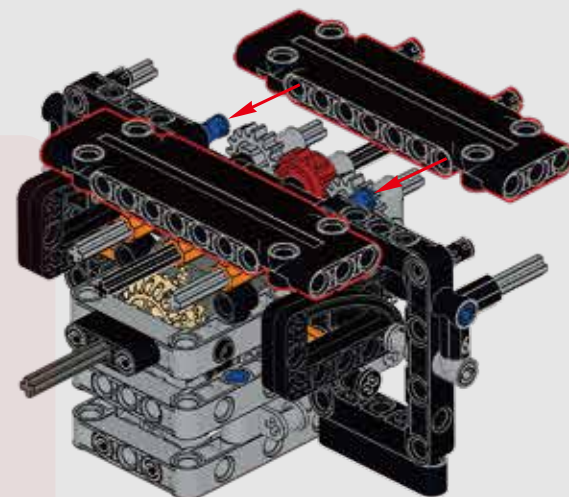

247

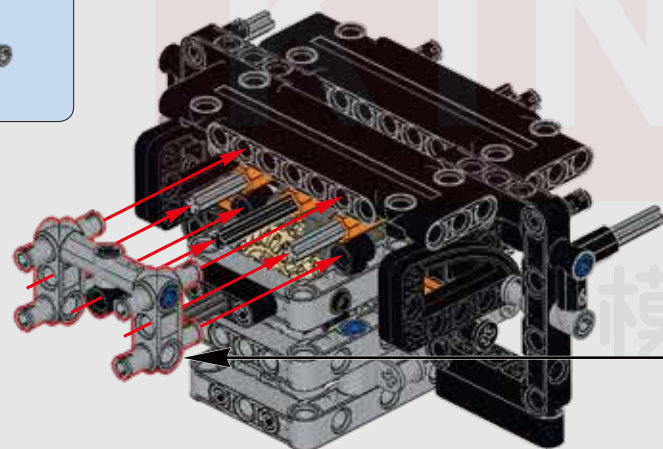

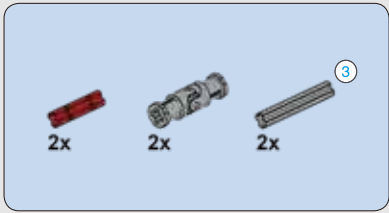

248

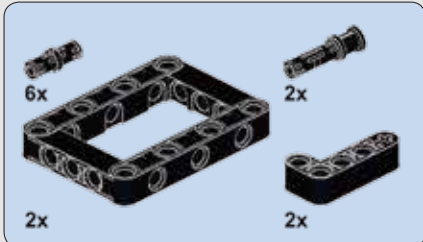
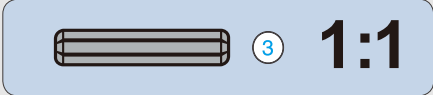
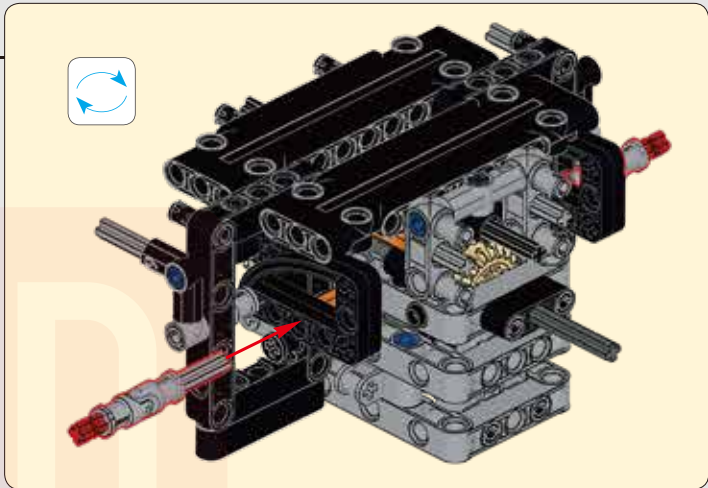
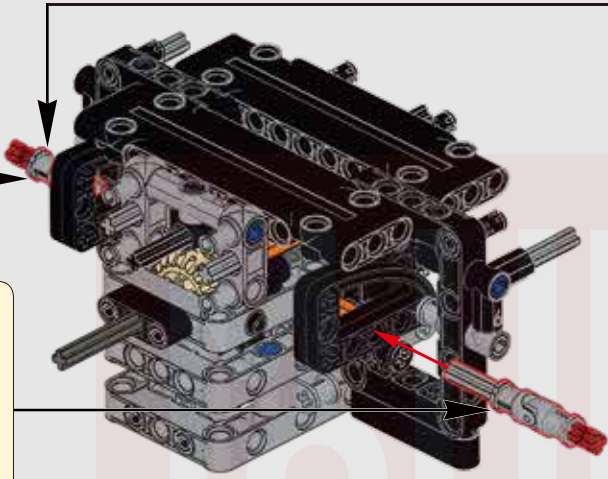
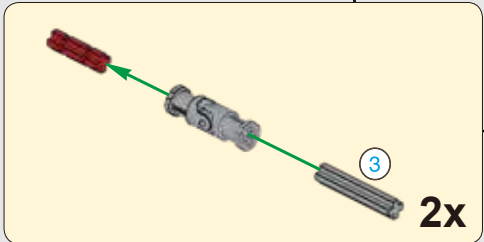

249

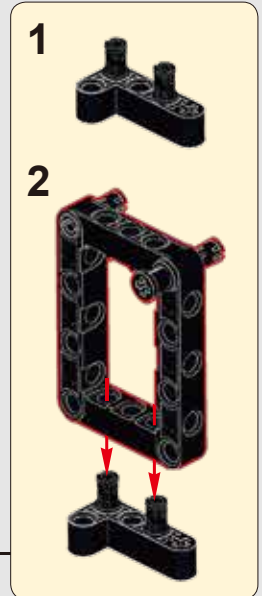
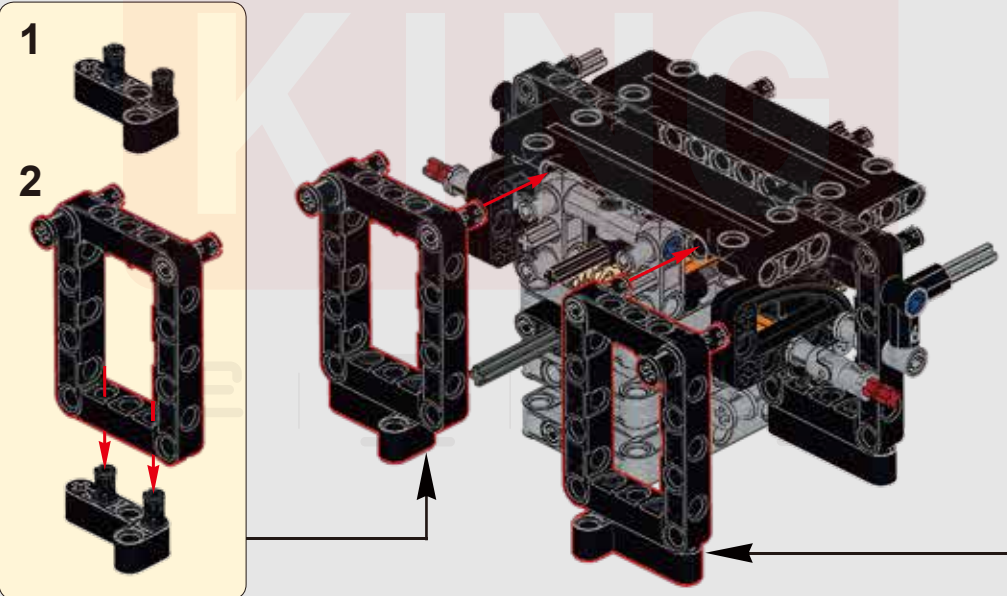
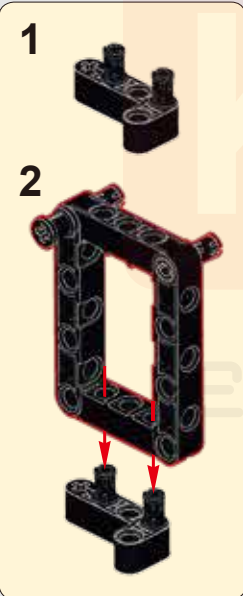

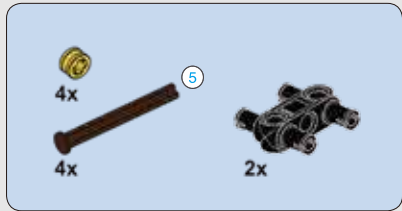

250

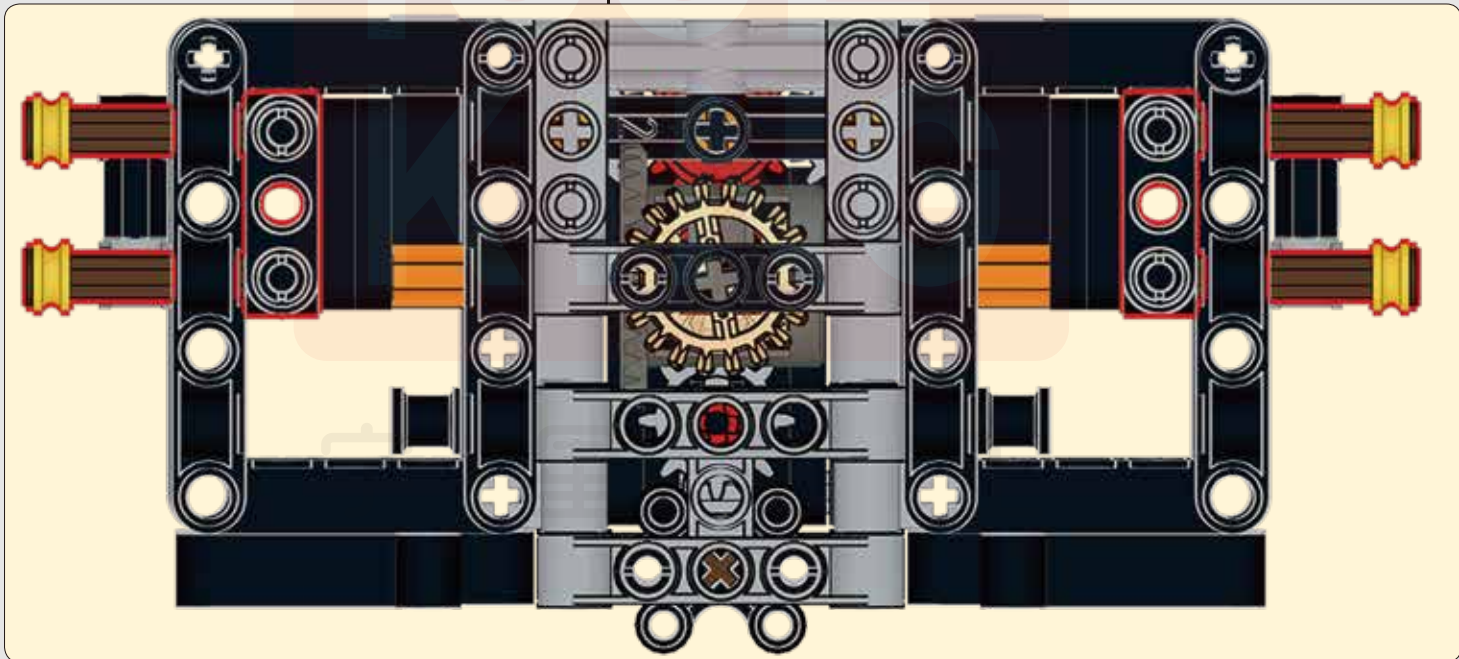
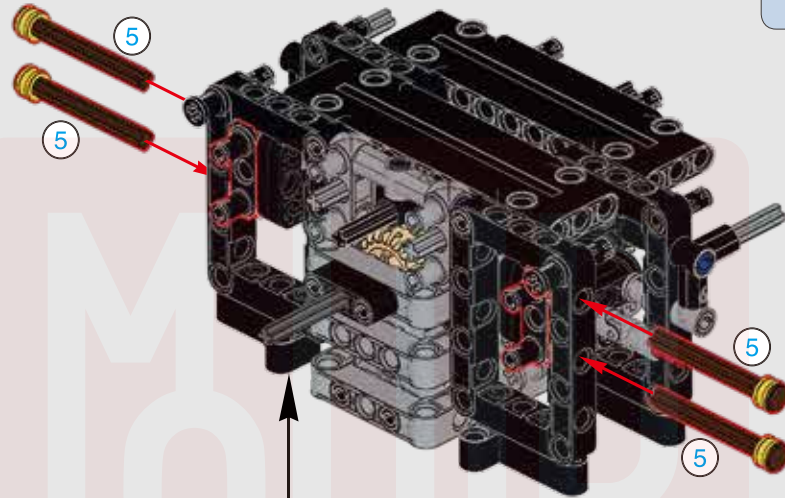
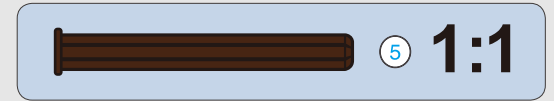

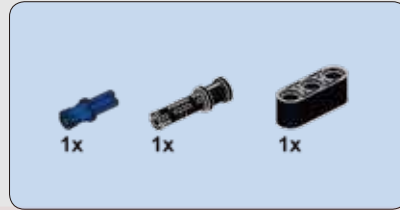
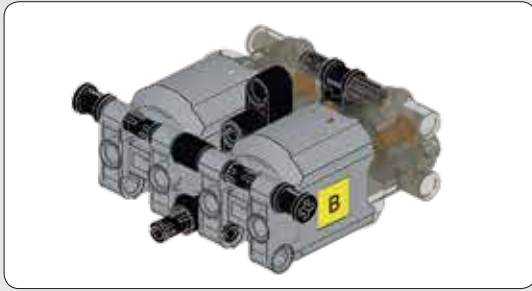

252

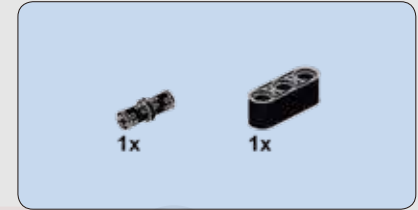

253

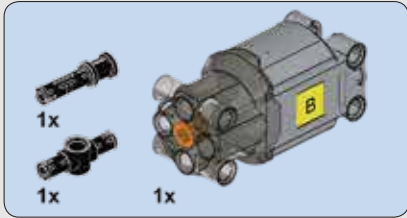

251

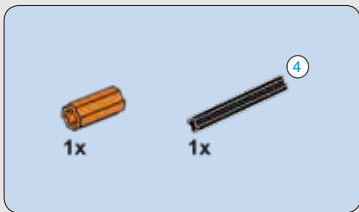
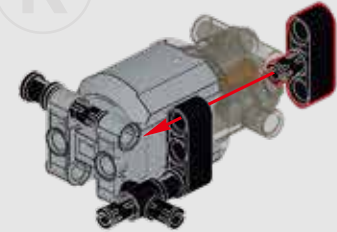
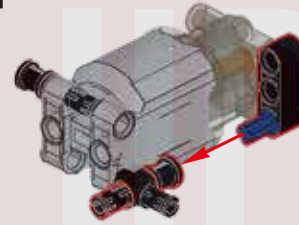
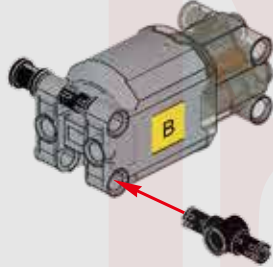

254

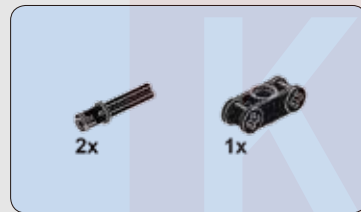

255

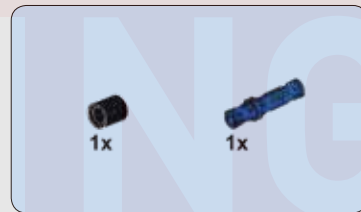

256

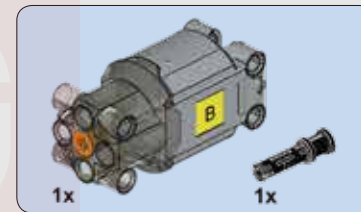

257

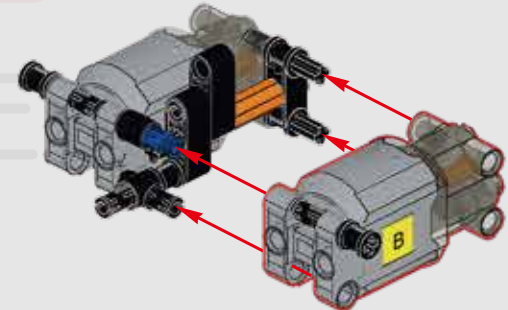
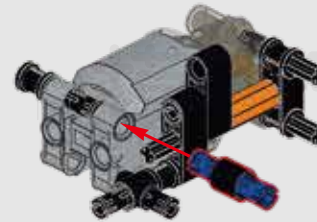
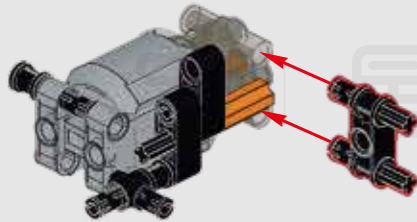
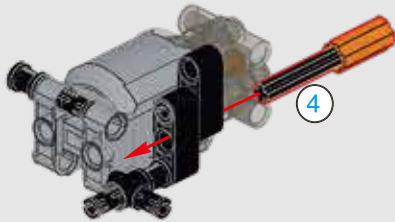

258

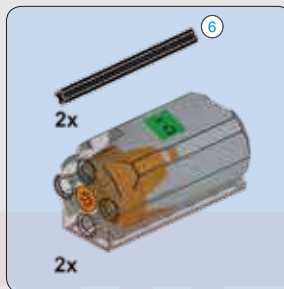
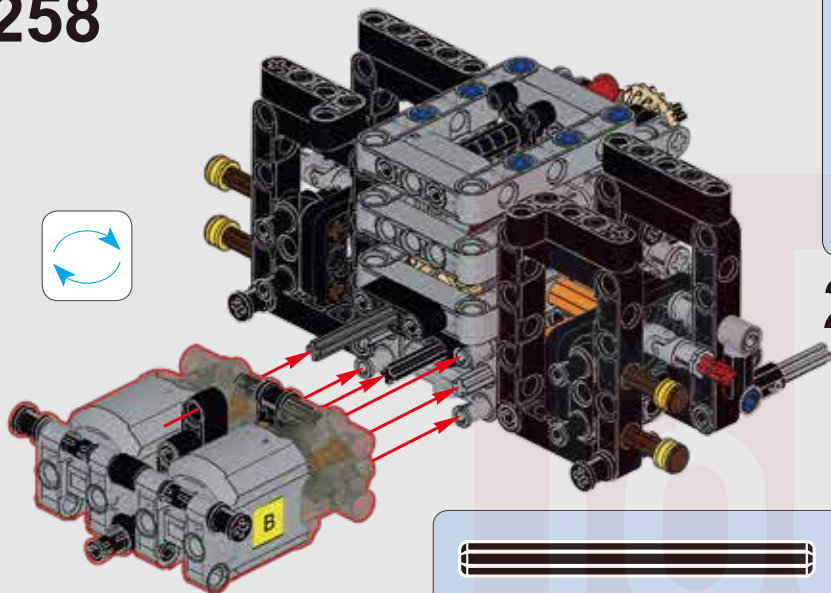

259

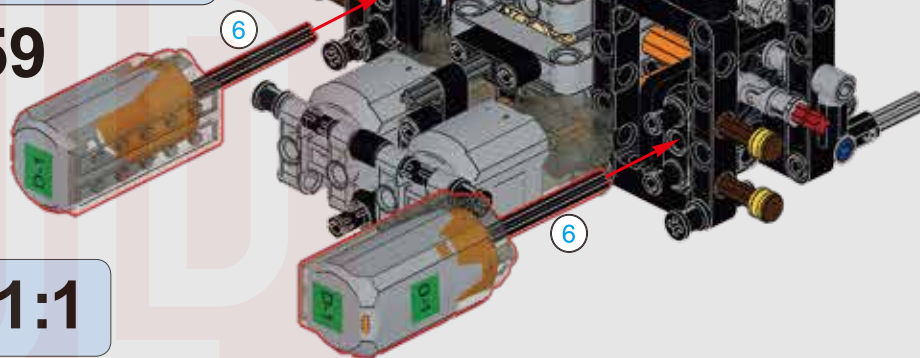

260

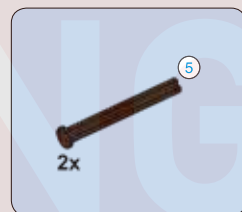
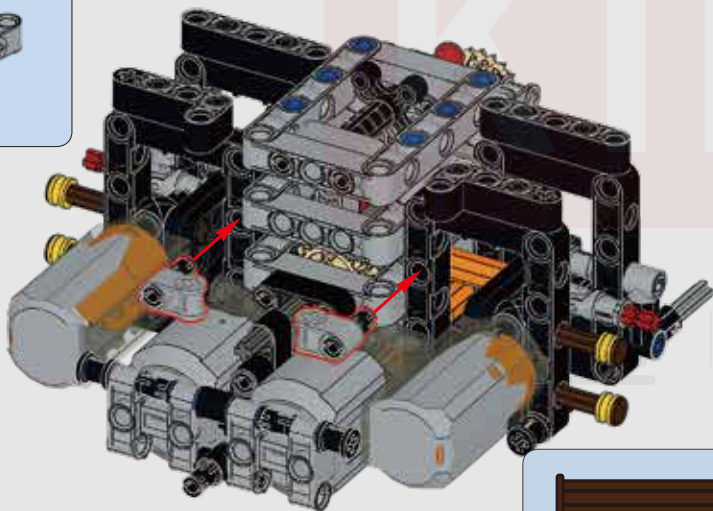

261

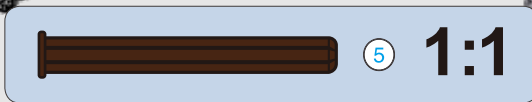
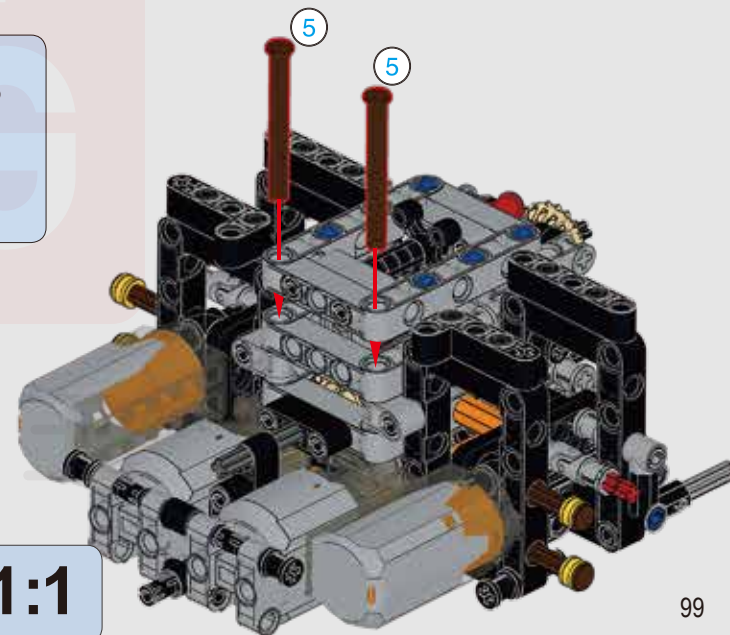

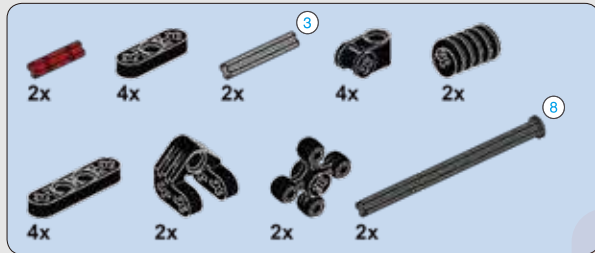

262

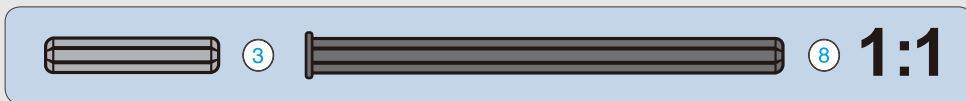
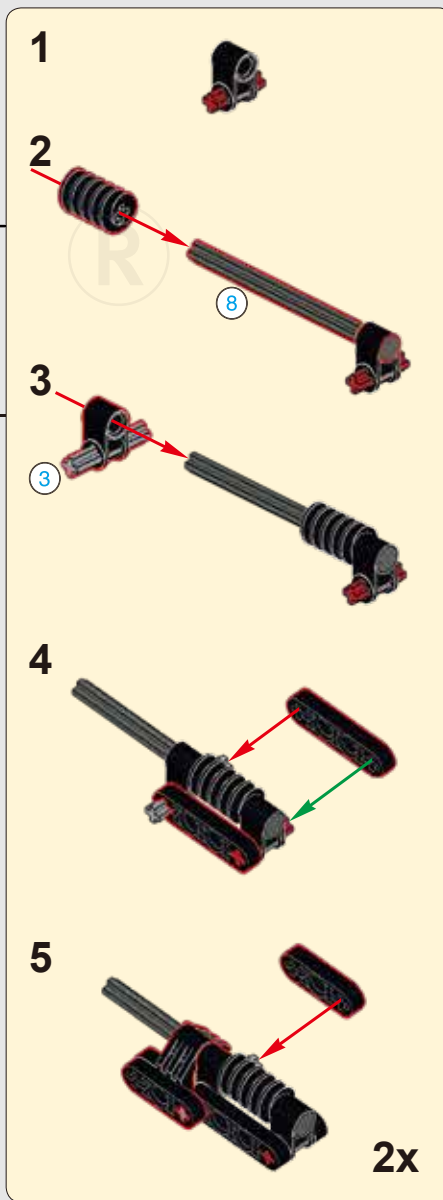
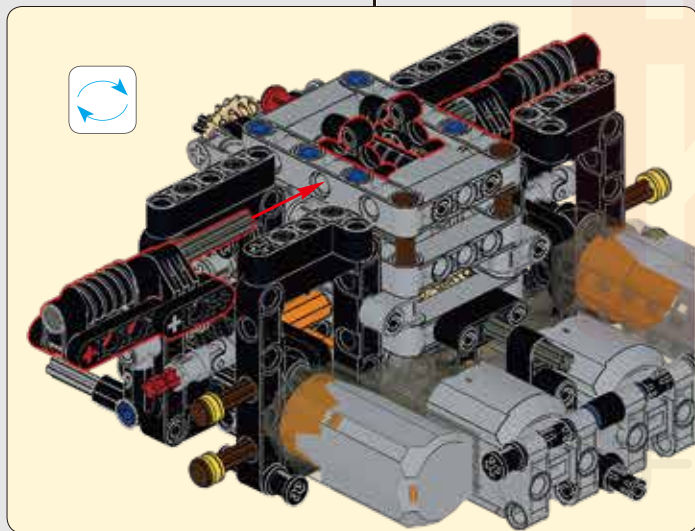
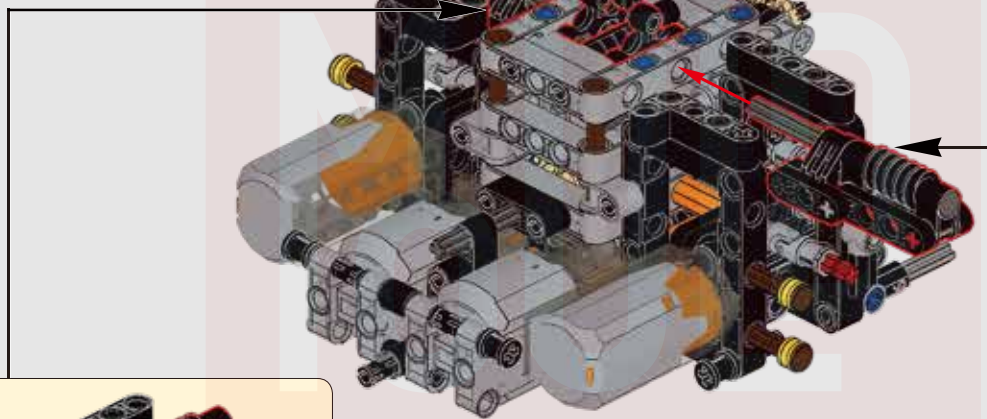

KING
星模王

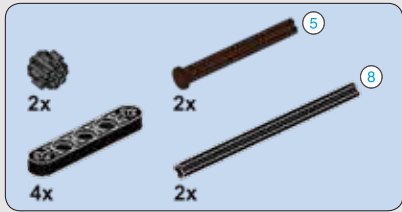

263

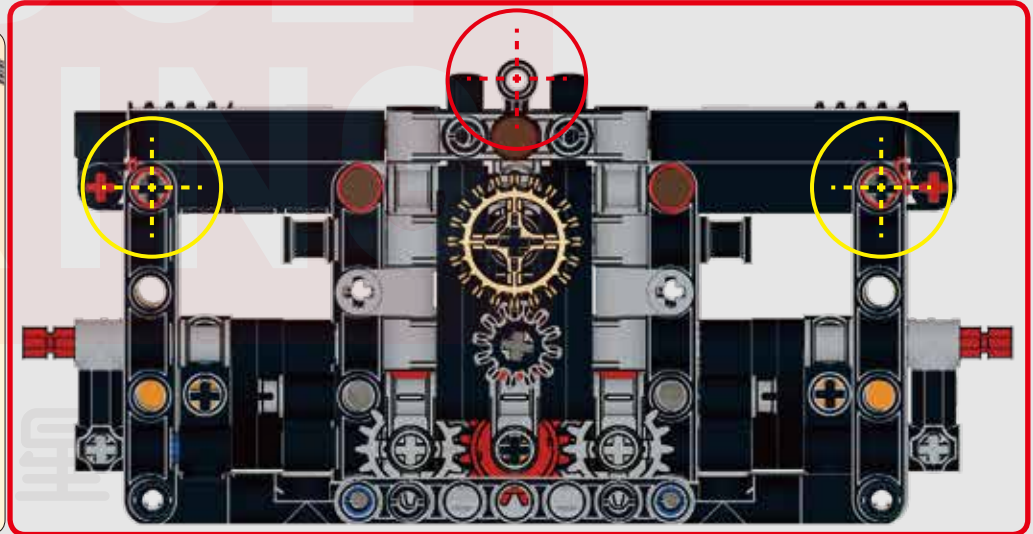
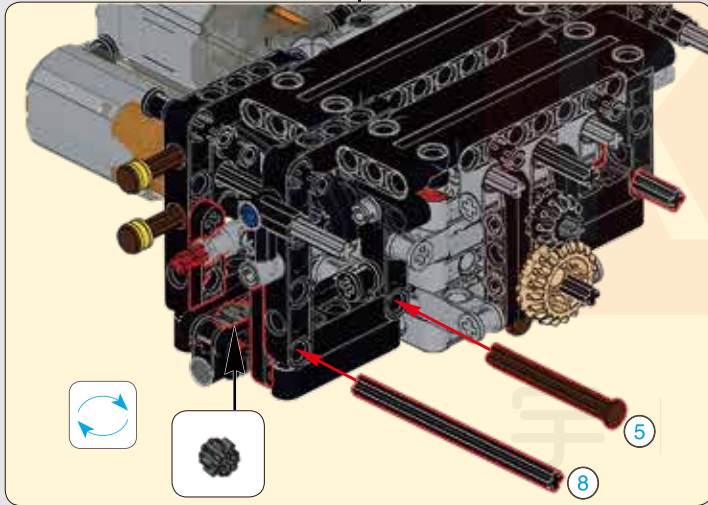
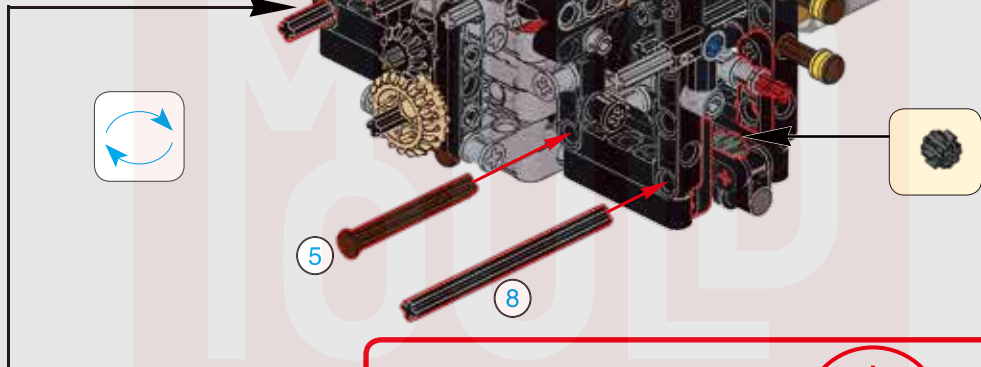



注意：拼装说明请参考13090 迈凯伦P1静态说明第125-126页396-400步
Note: Please refer to step 396-400 on page 125-126 of 13090 McLaren P1 Manual Version for assembly instructions.



注意：拼装说明请参考13090 迈凯伦P1静态说明第124-125页391-395步
Note: Please refer to step 391-395 on page 124-125 of 13090 McLaren P1 Manual Version for assembly instructions.

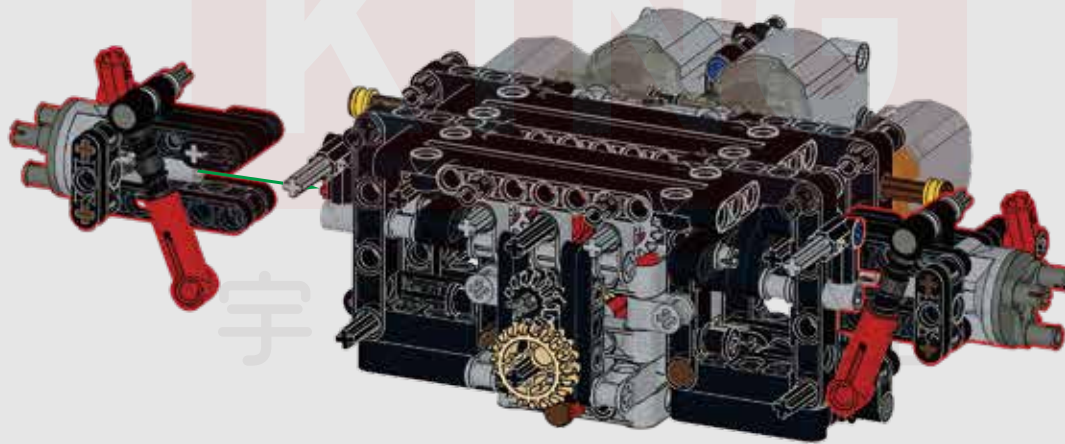

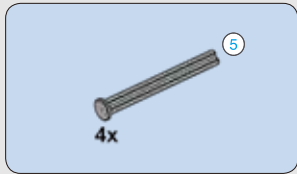

265

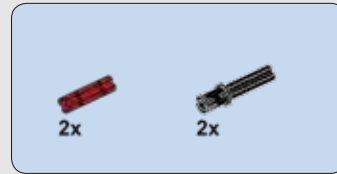
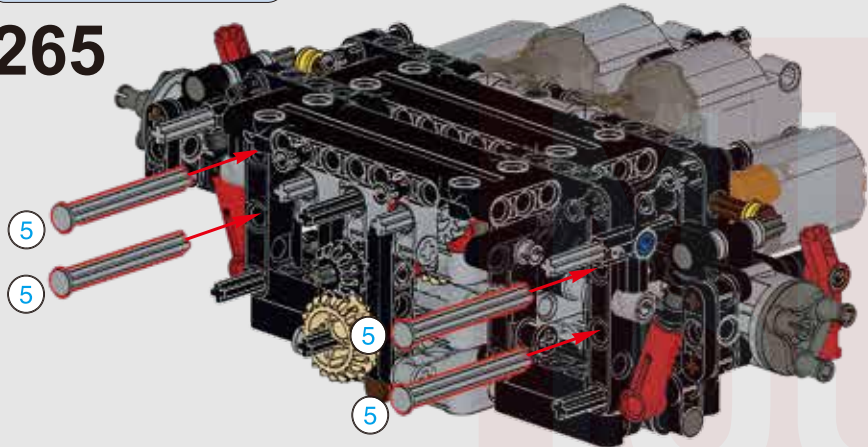

266

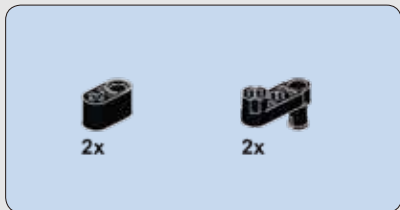
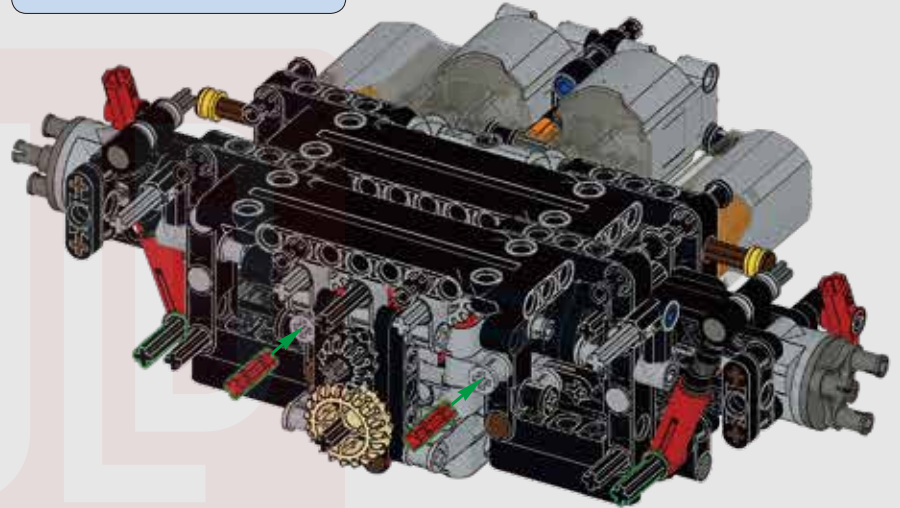

267

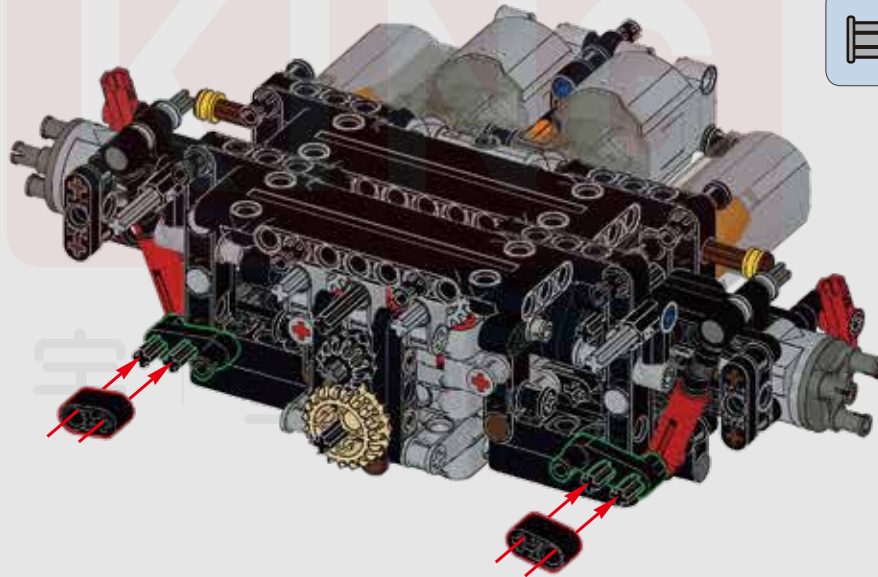

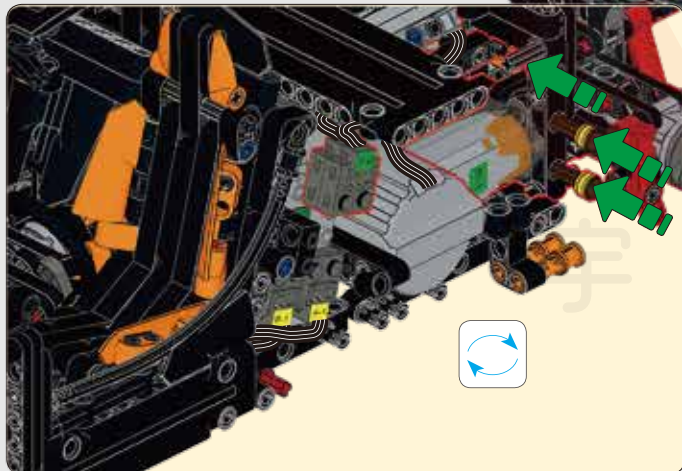
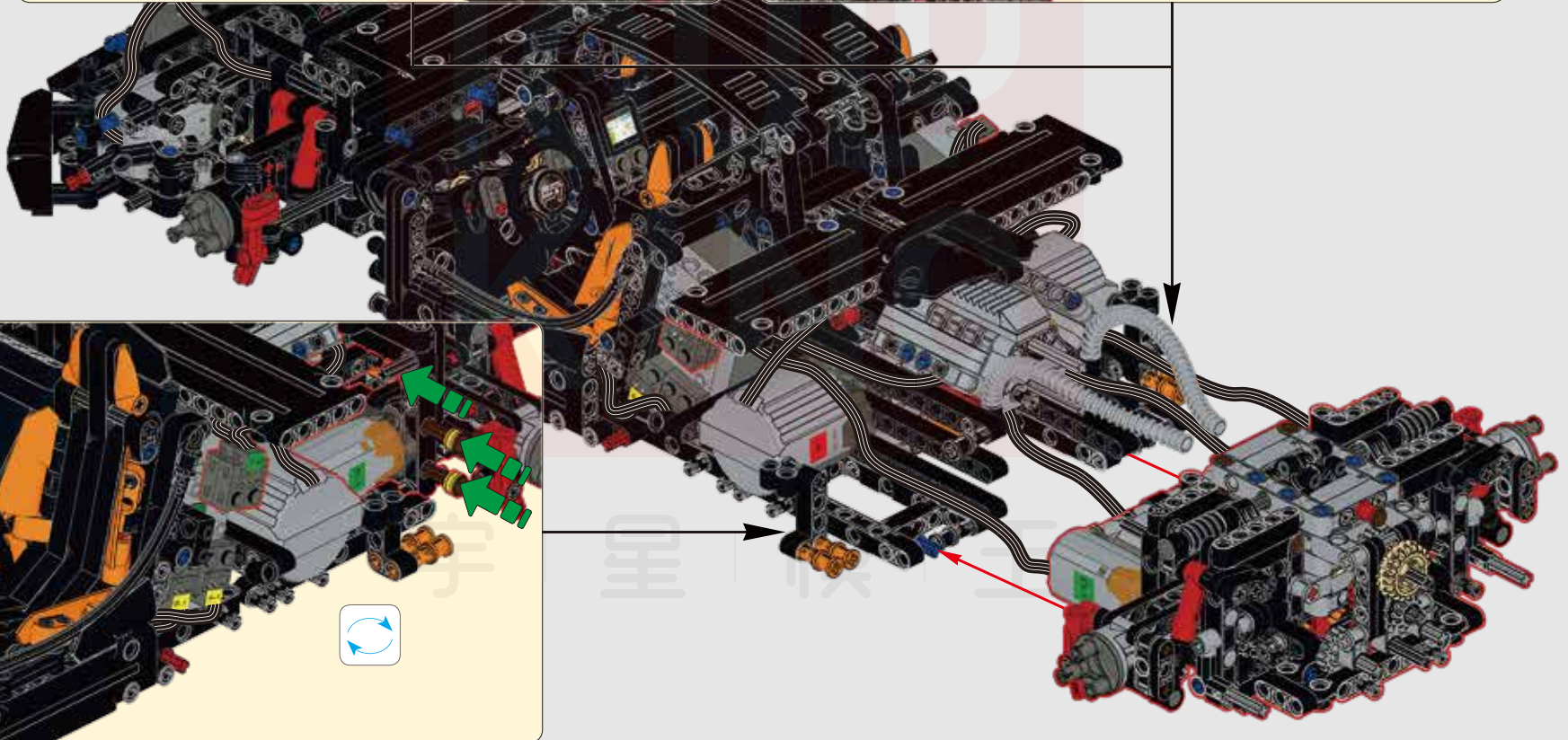
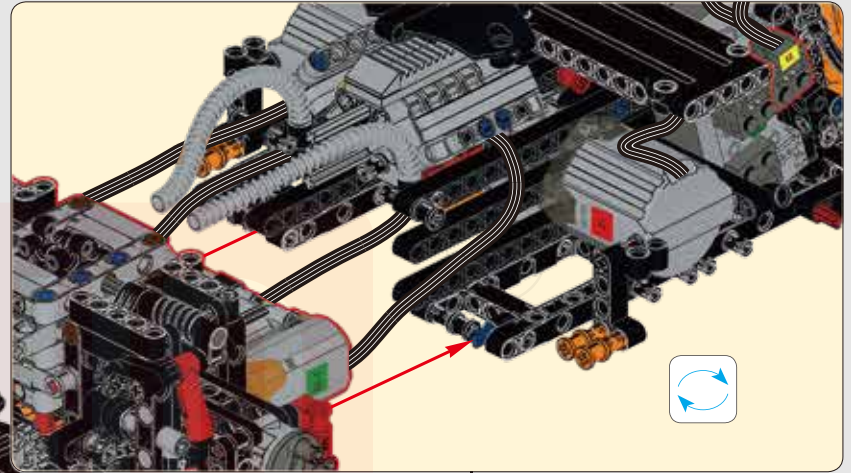
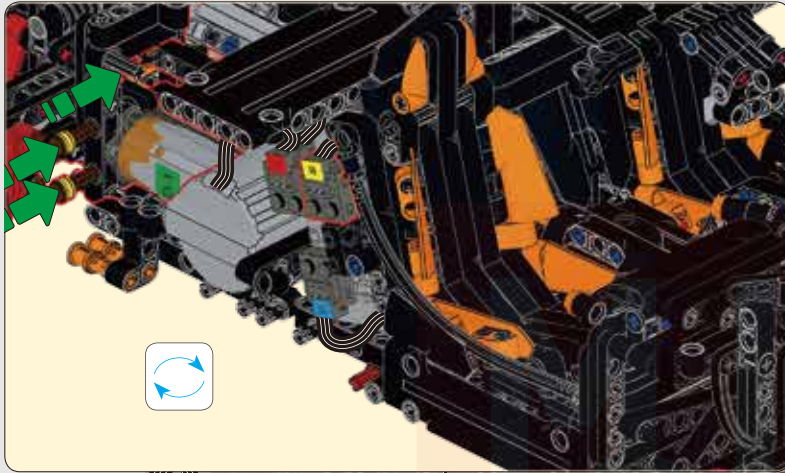

底盘水平校准 Chassis horizontal calibration

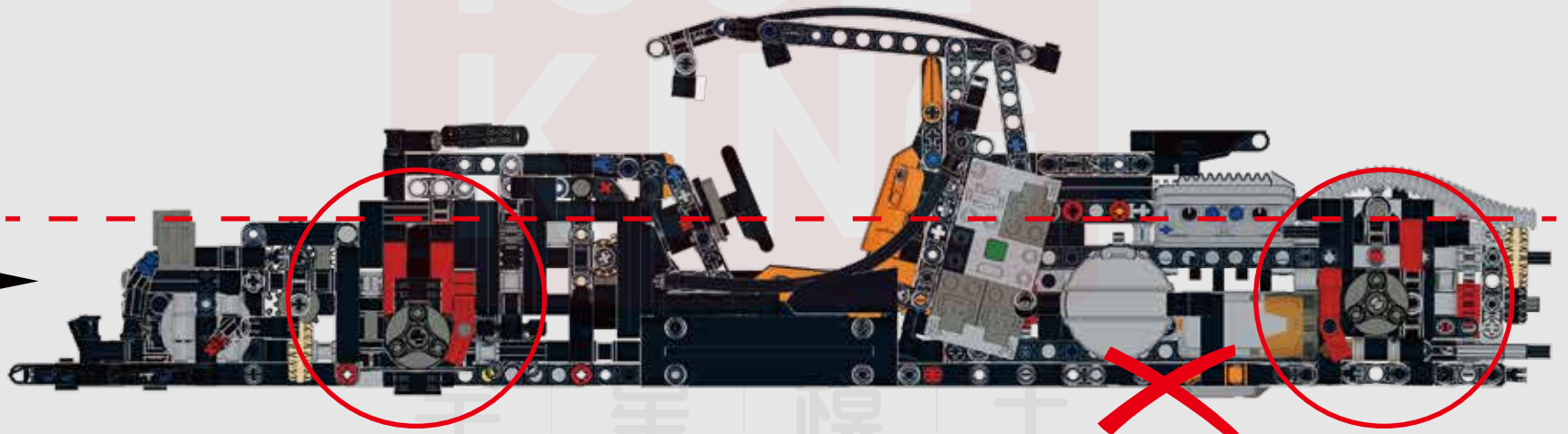
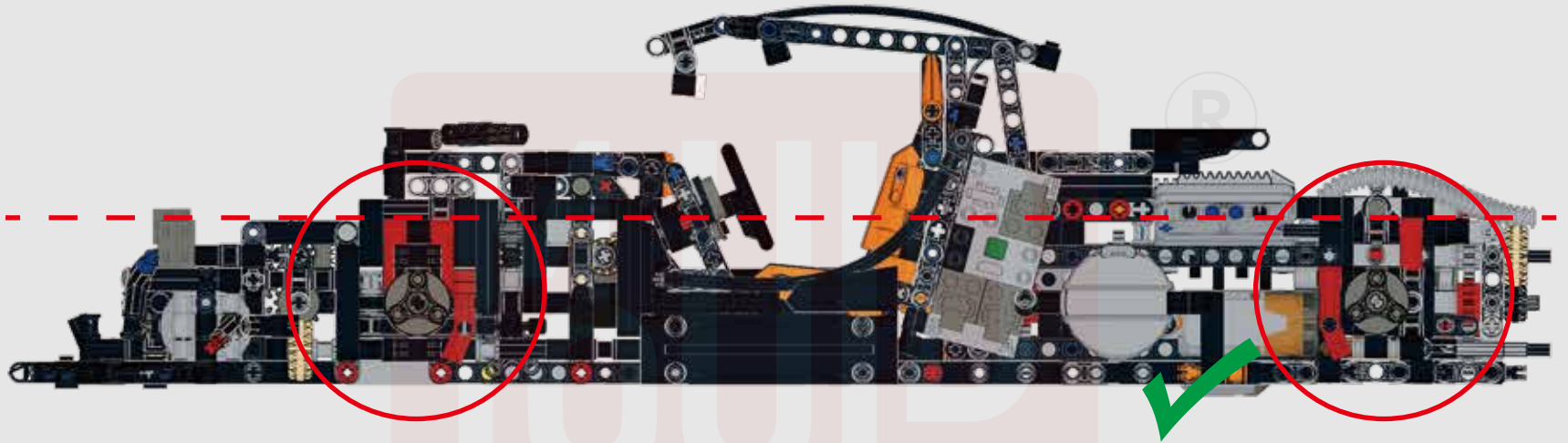



注意：拼装说明请参考13090 迈凯伦P1静态说明第104页325-327步

Note: Please refer to step 325-327 on page 104 of 13090 McLaren P1 Manual Version for assembly instructions.



注意：拼装说明请参考13090 迈凯伦P1静态说明第104页328-330步

Note: Please refer to step 328-330 on page 104 of 13090 McLaren P1 Manual Version for assembly instructions.

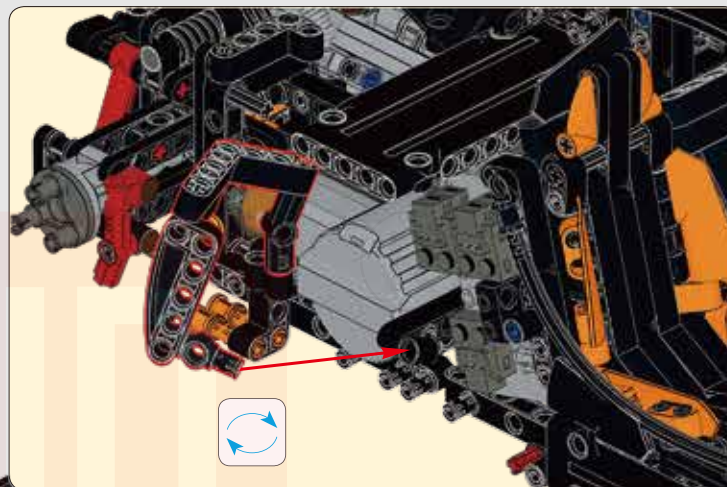

269

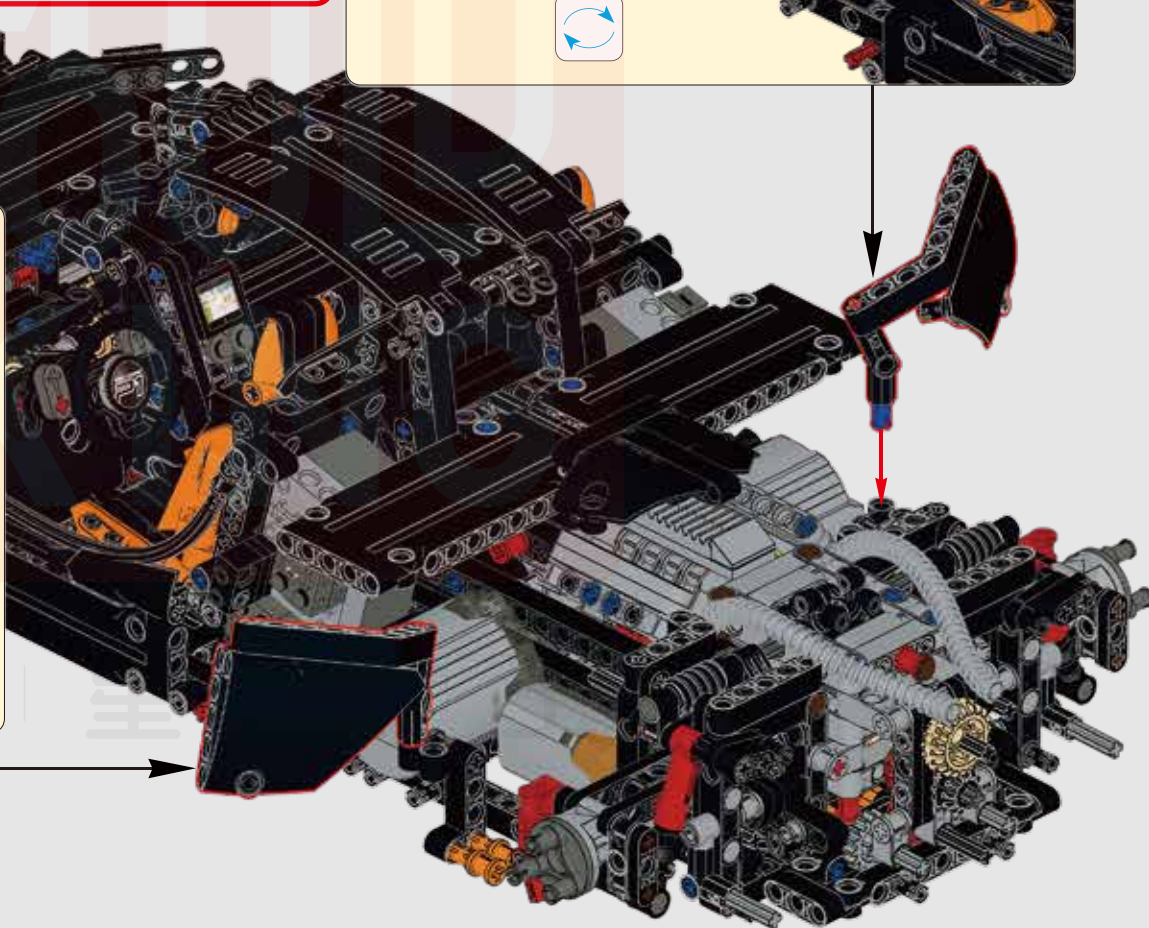
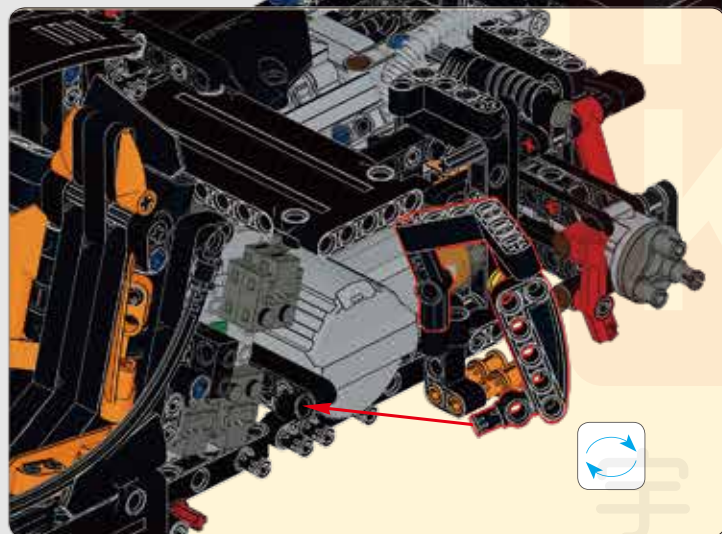

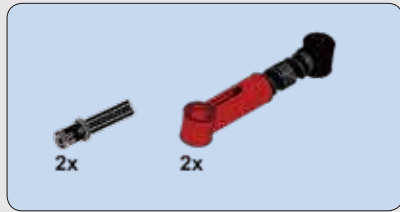

270

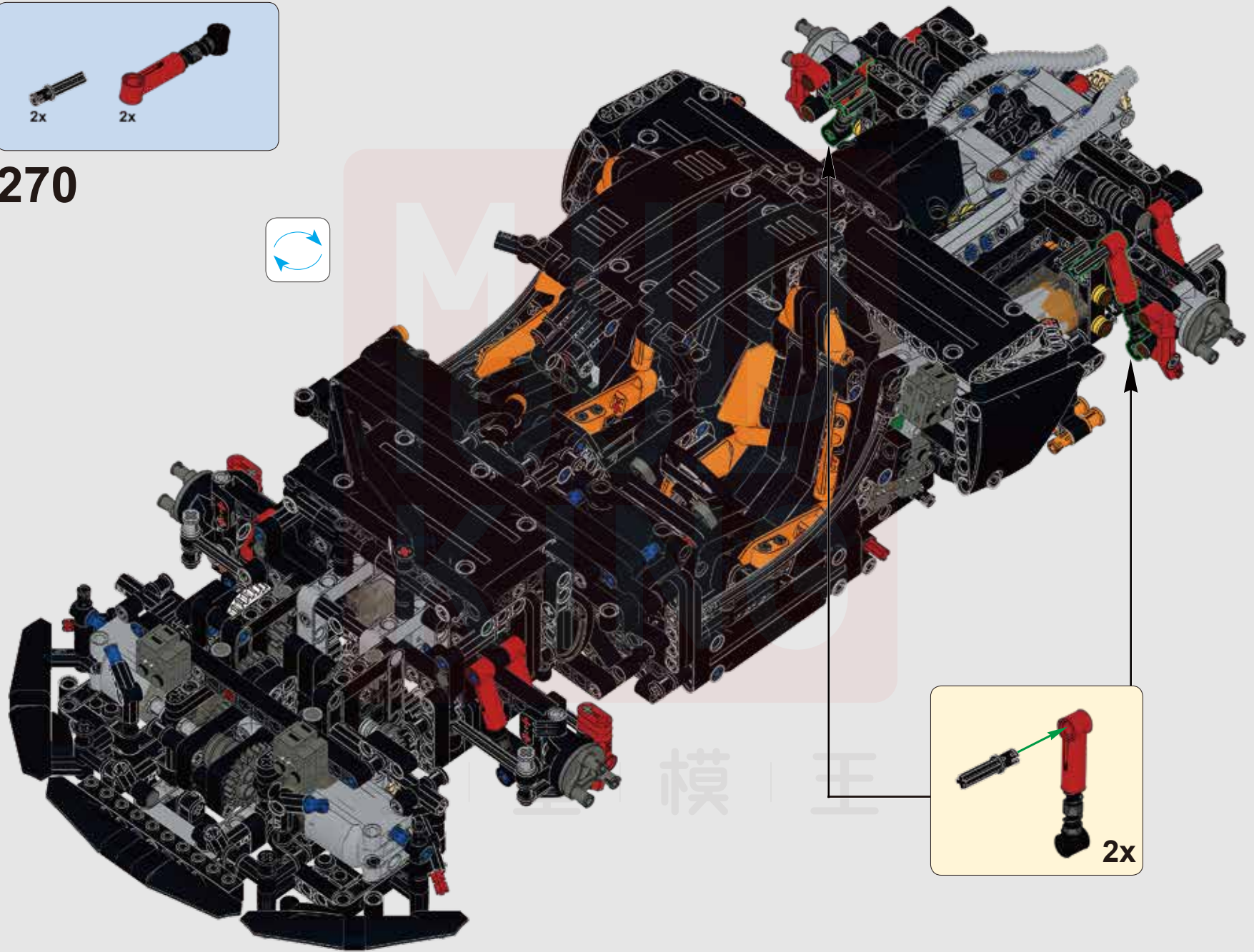

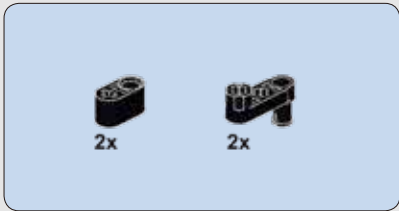

271

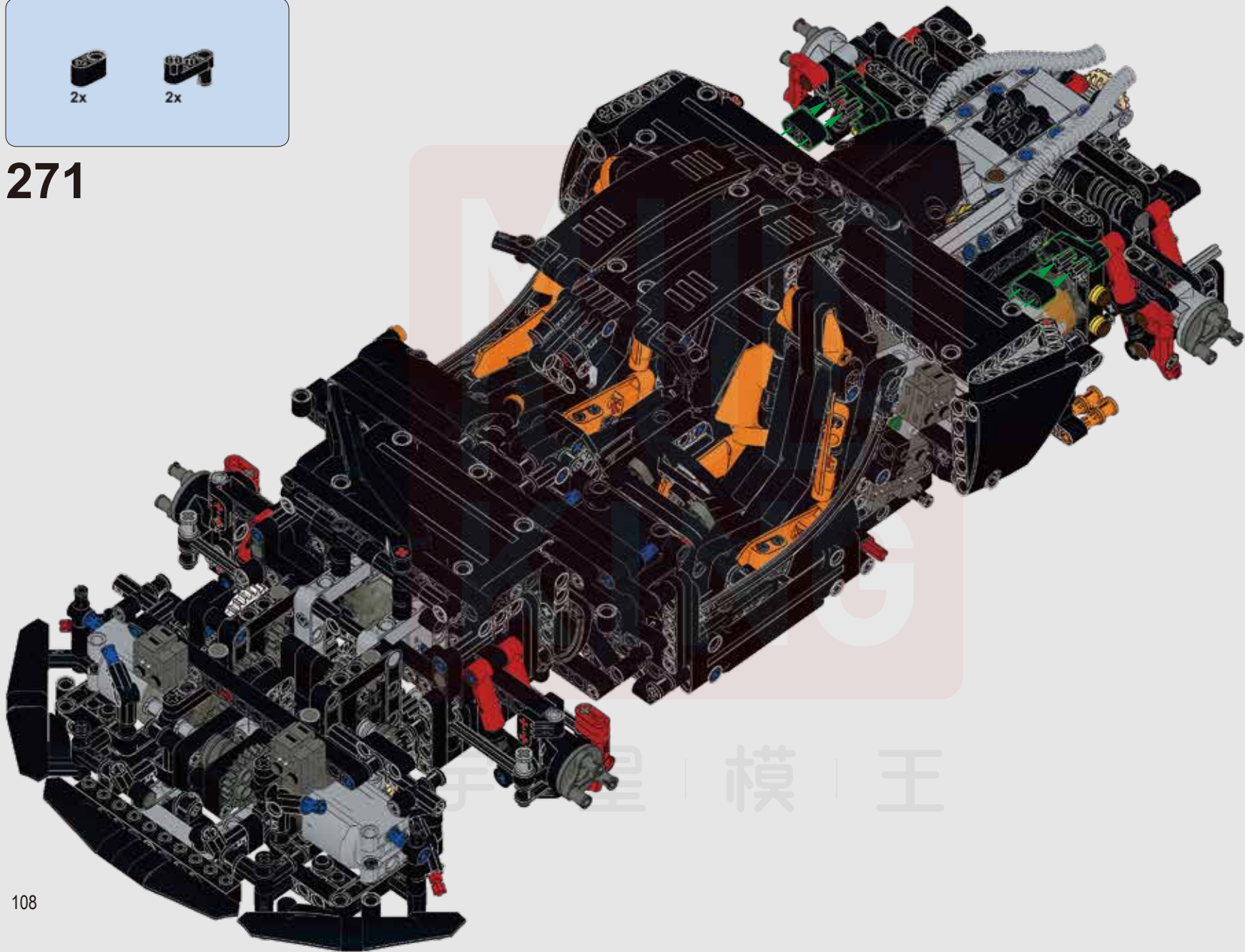

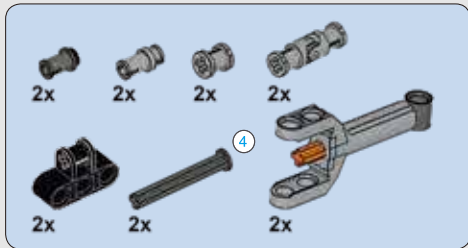

272

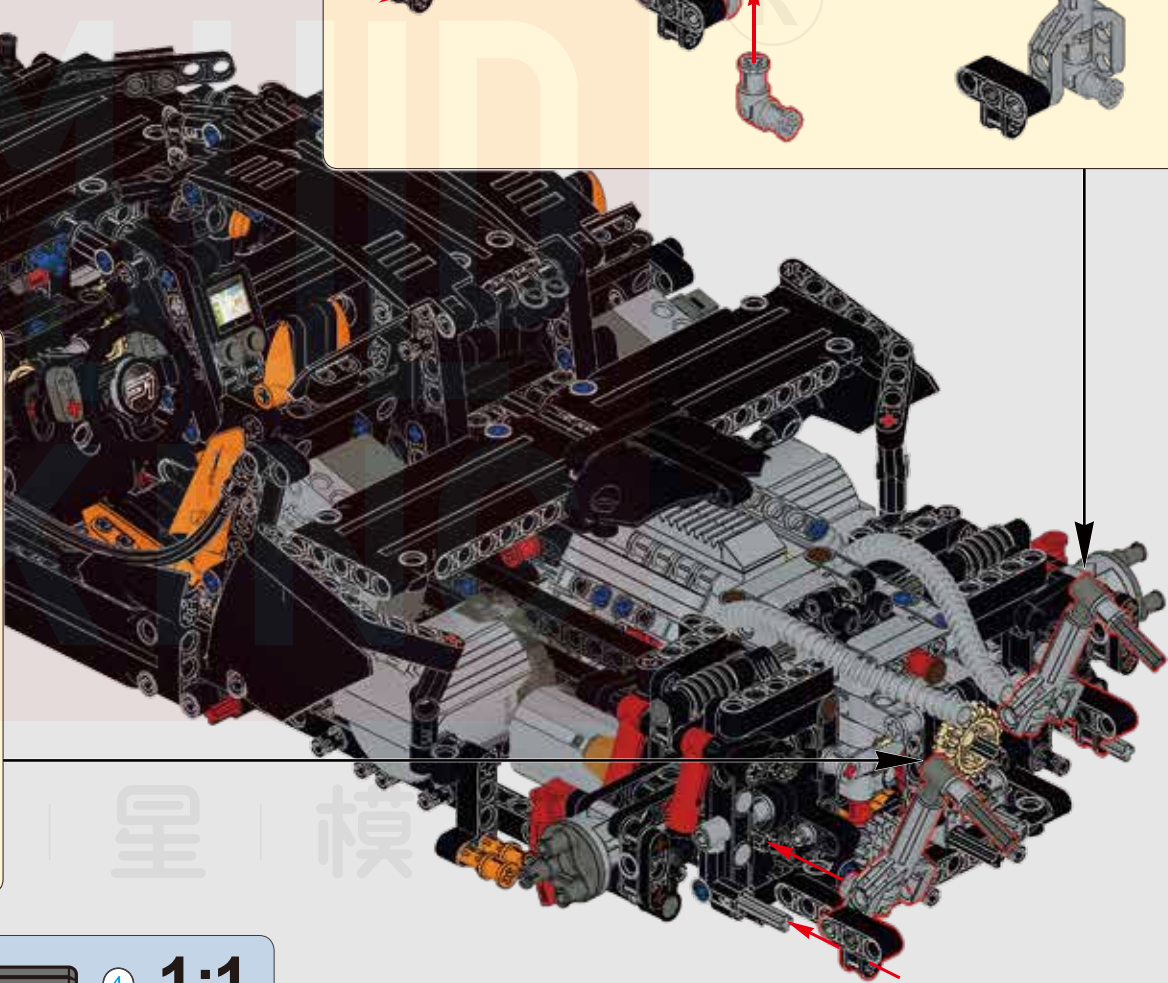
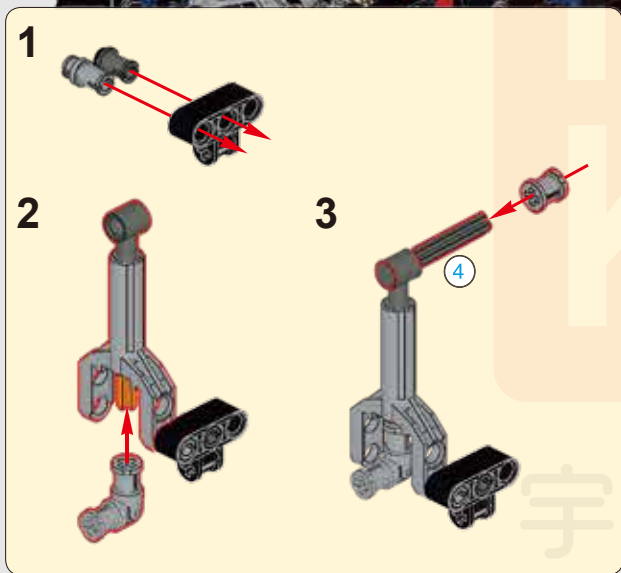
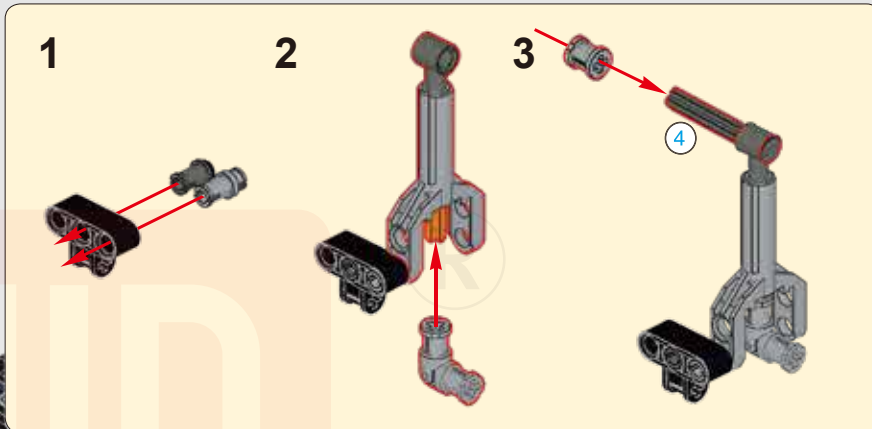
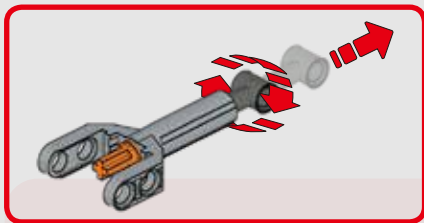

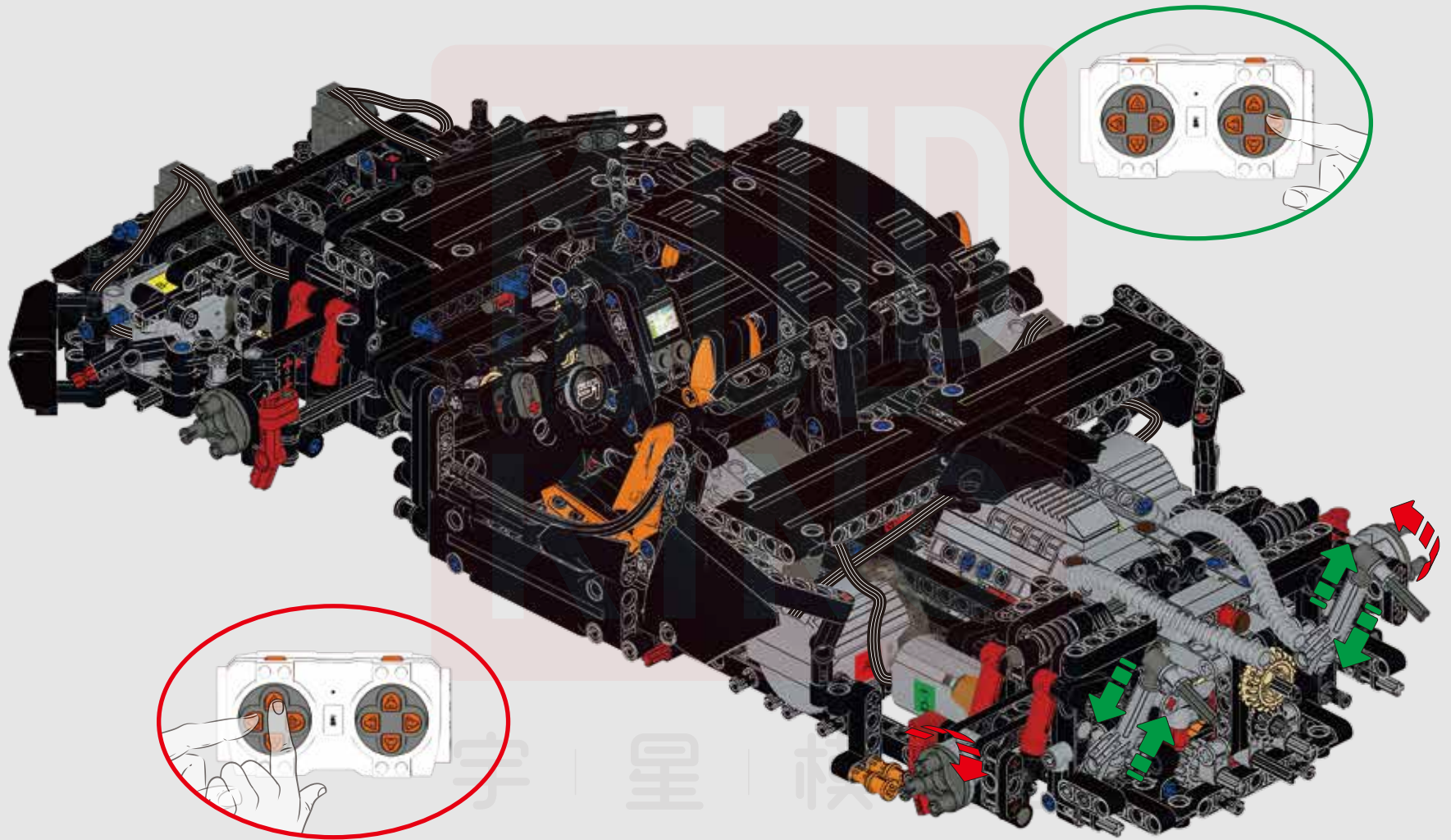

274

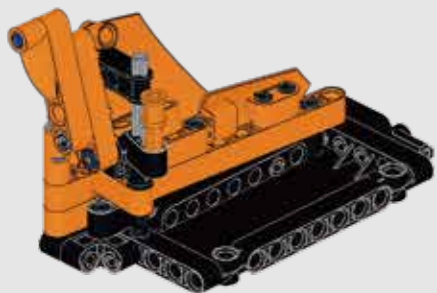

注意：拼装说明请参考13090迈凯伦P1静态说明第133-136页408-423步
Note:Please refer to step 408-423 on page 133-136 of 13090 McLaren P1 Manual Version for assembly instructions.

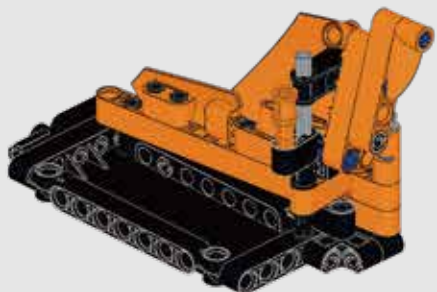

注意：拼装说明请参考13090迈凯伦P1静态说明第137-140页424-439步
Note:Please refer to step 424-439 on page 137-140 of 13090 McLaren P1 Manual Version for assembly instructions.

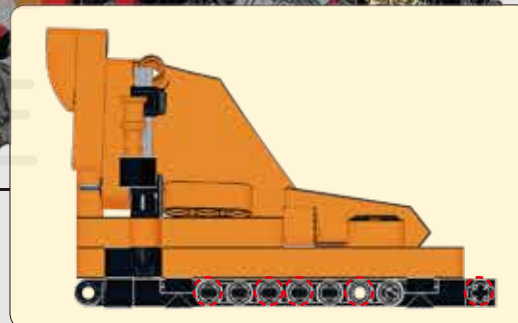
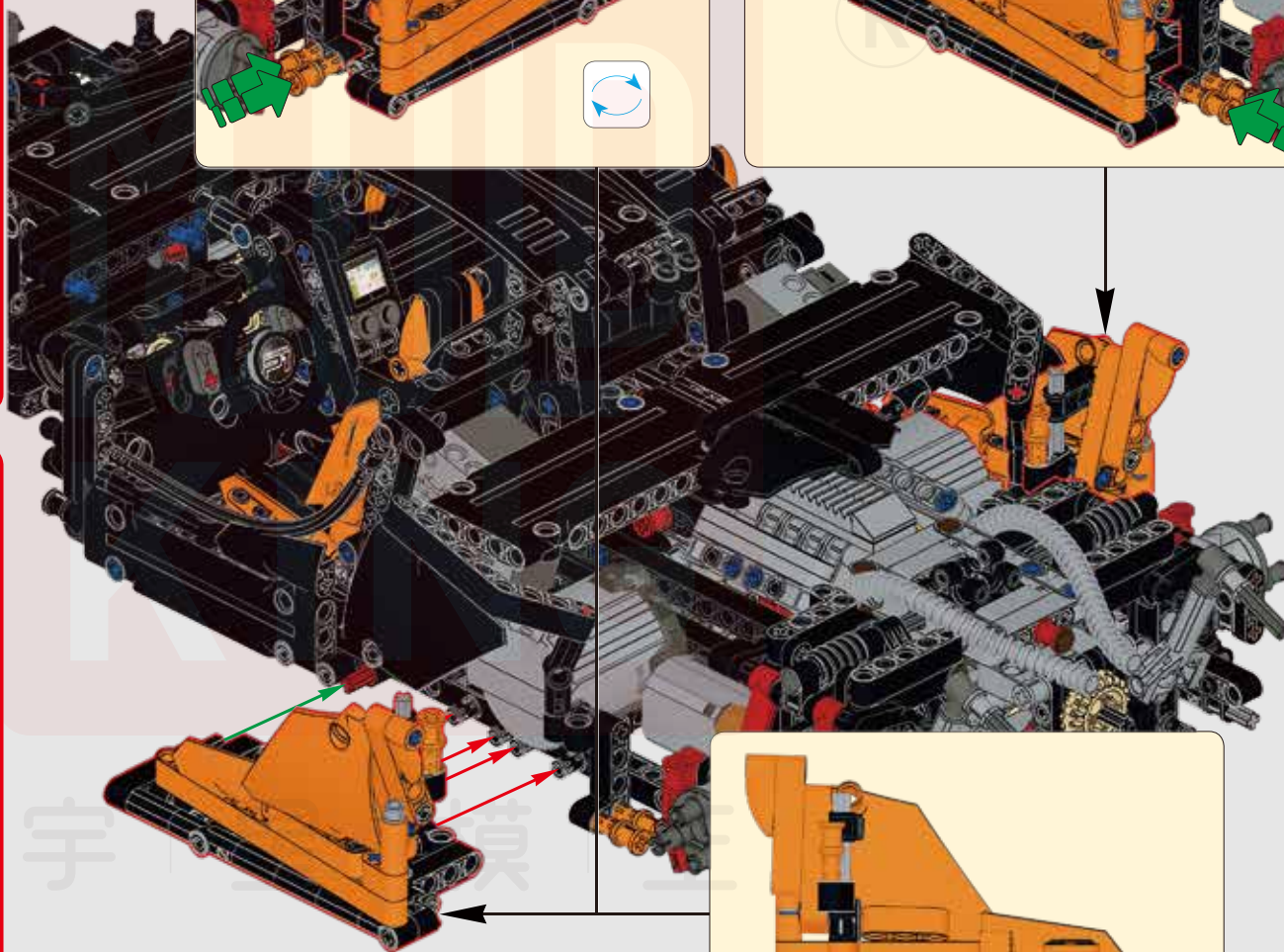
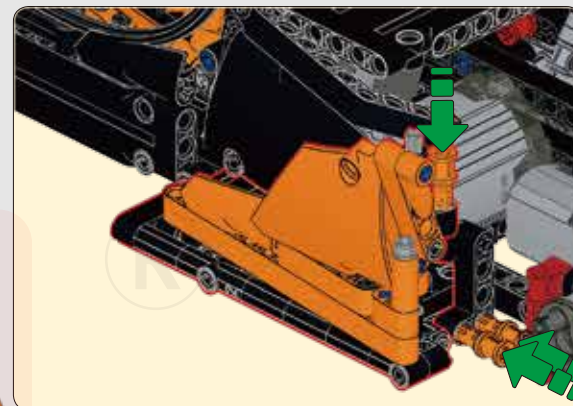
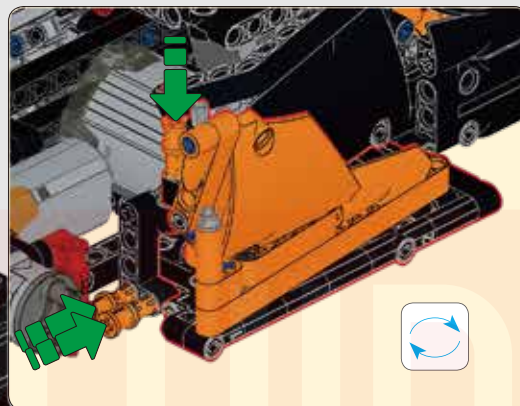

275



注意：拼装说明请参考13090 迈凯伦P1
静态说明第142-144页441-453步

**Note: Please refer to step 441-453 on
page 142-144 of 13090 McLaren P1
Manual Version for assembly instructions.**

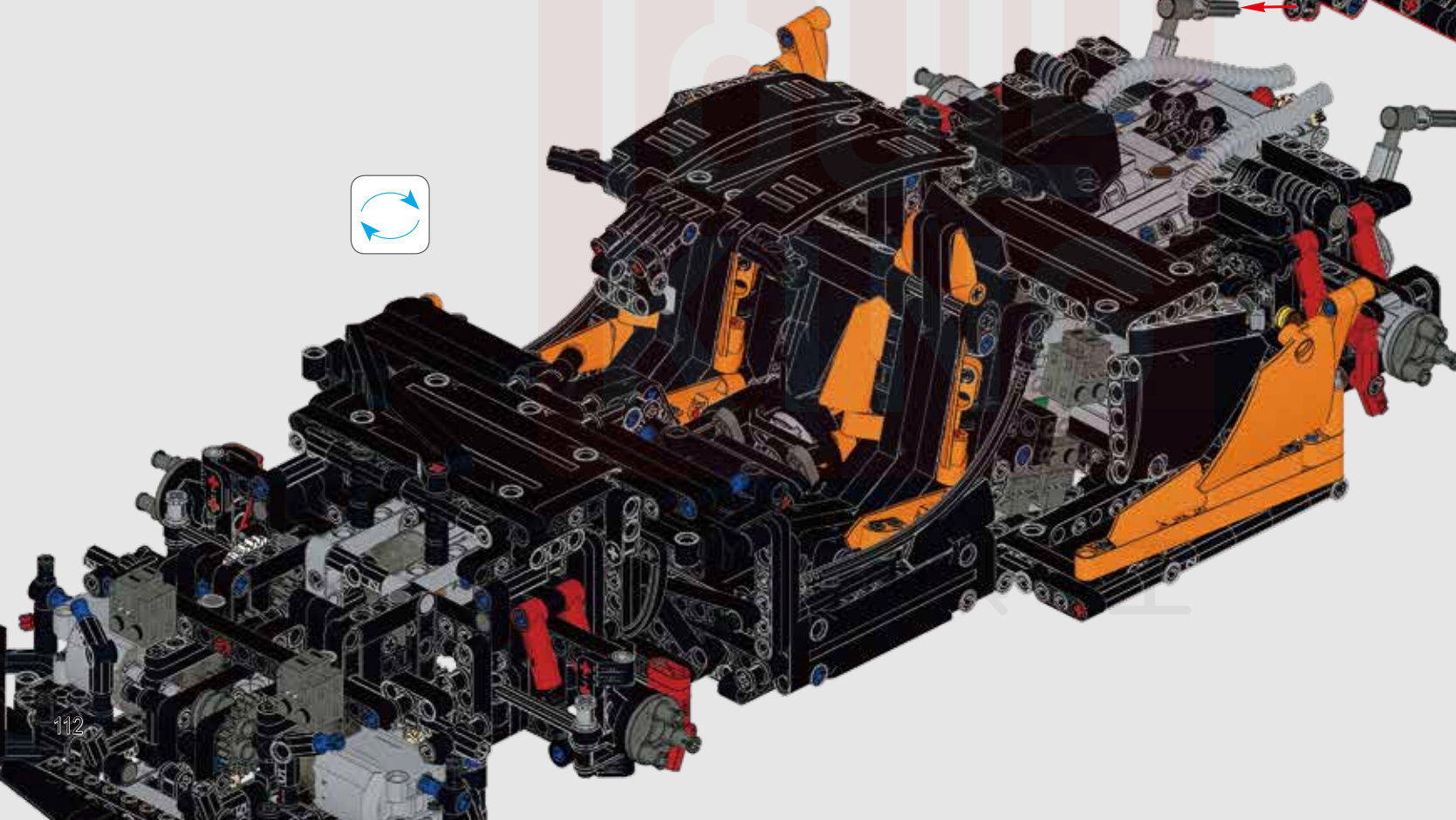
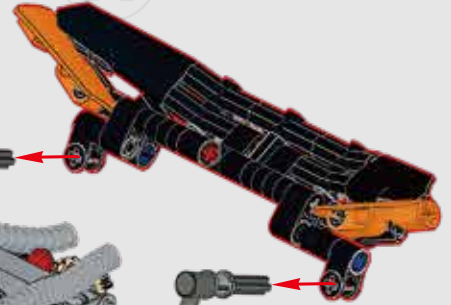

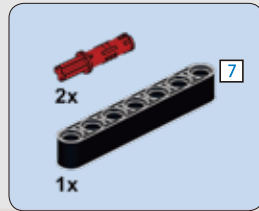
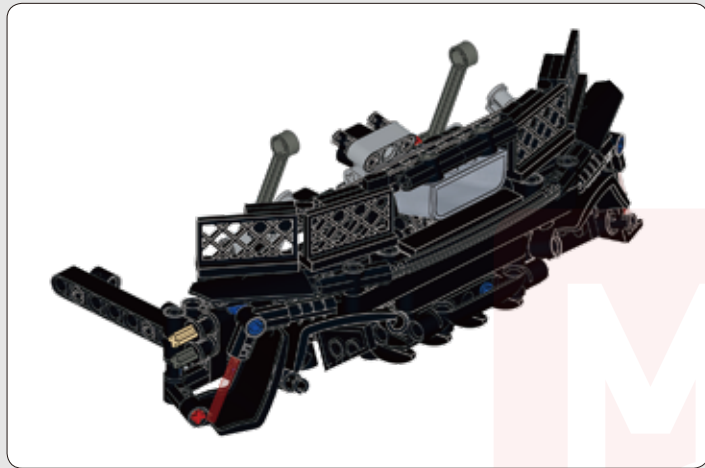

276

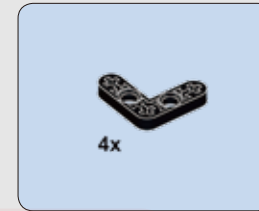
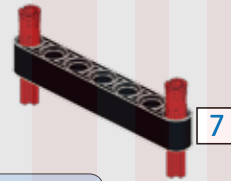

277

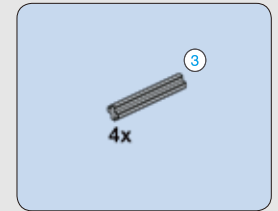
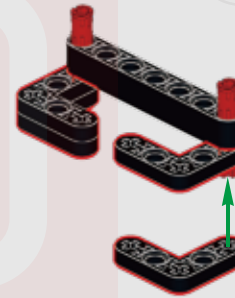

278

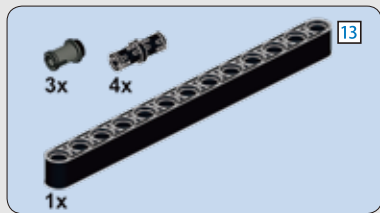
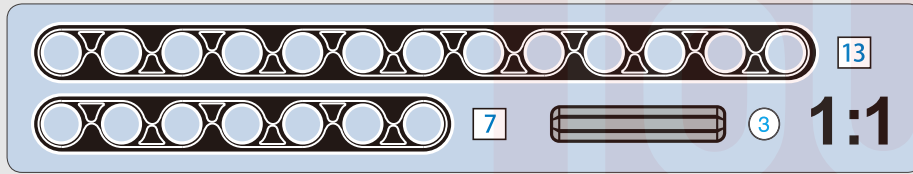
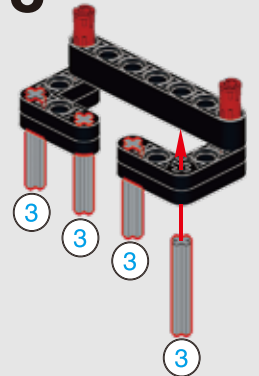

279

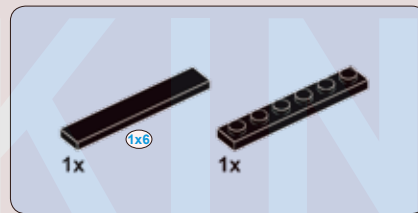
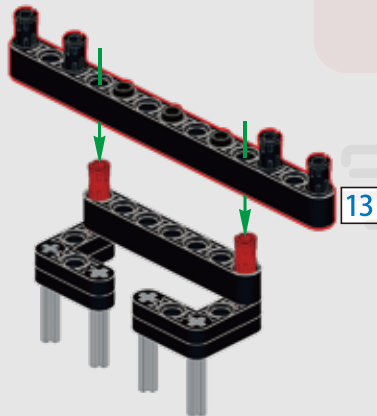

280

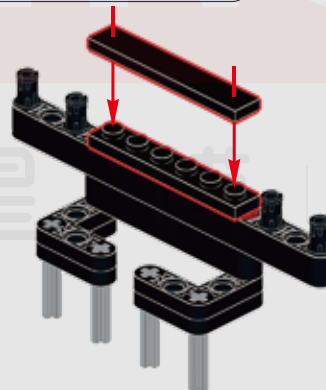

281

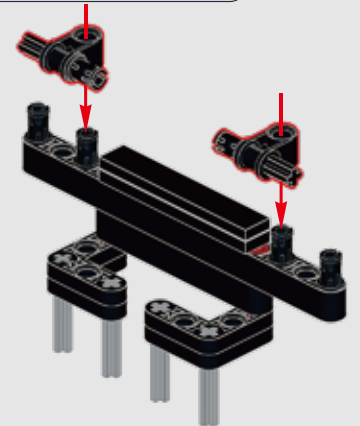

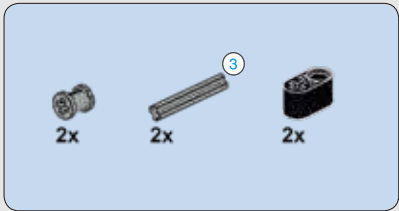

282

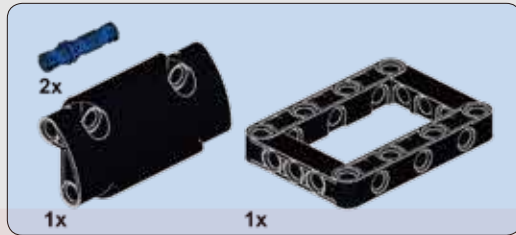
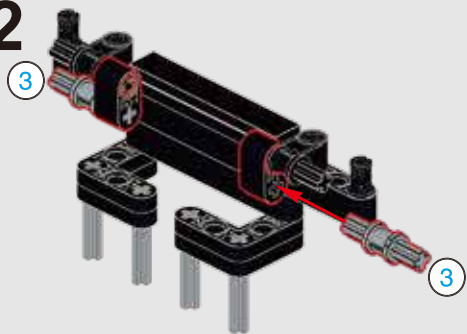

283

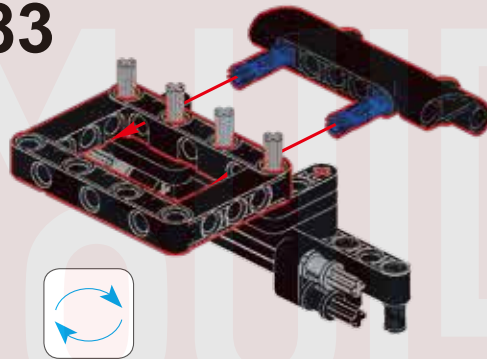

284

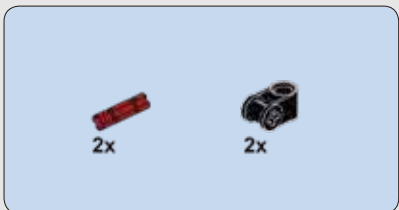
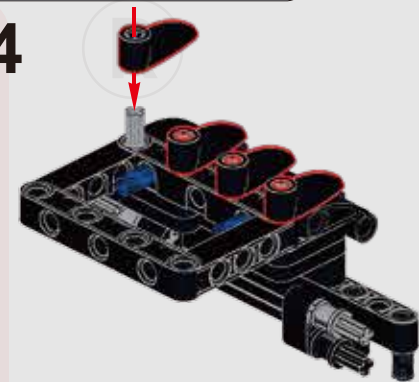

285

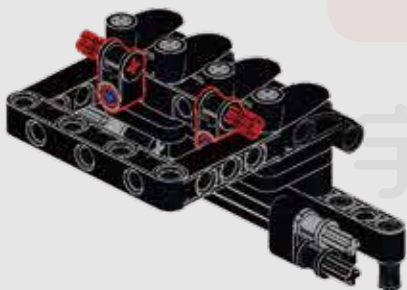

286

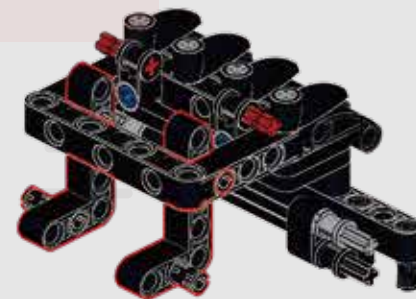

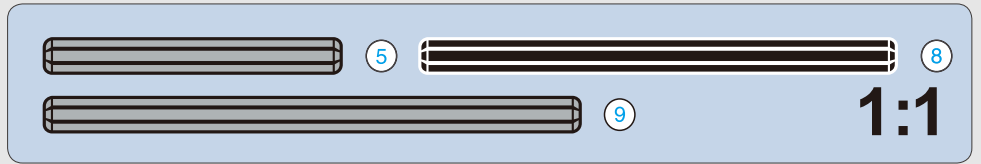
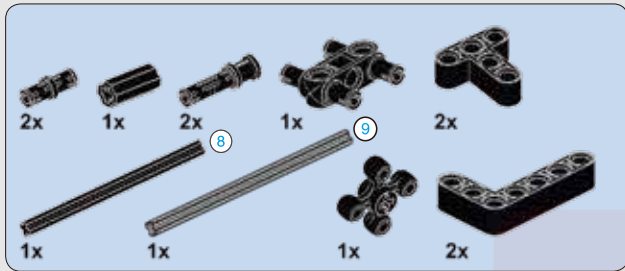

287

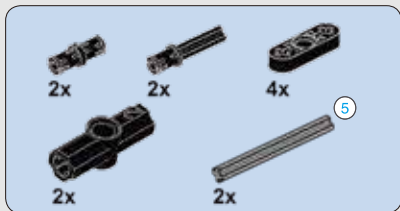
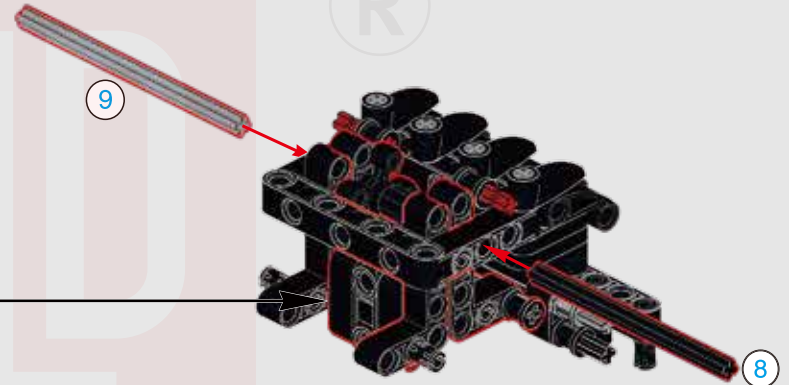
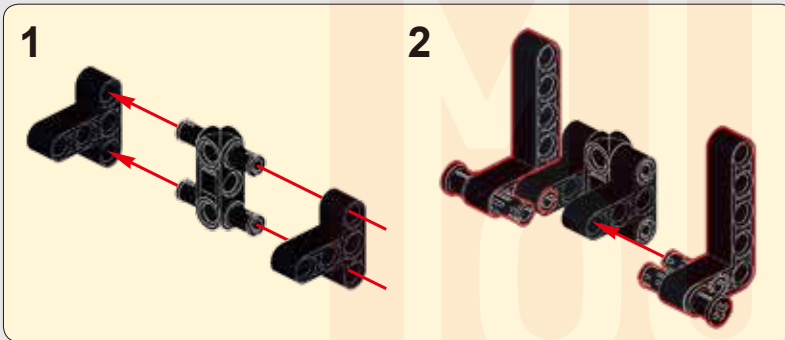

288

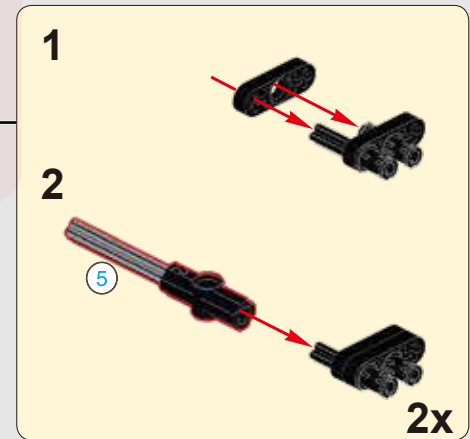
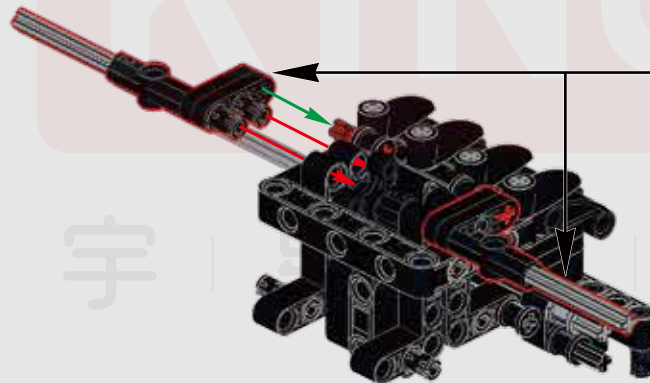

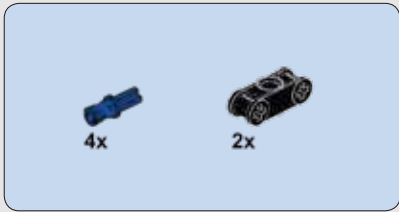

289

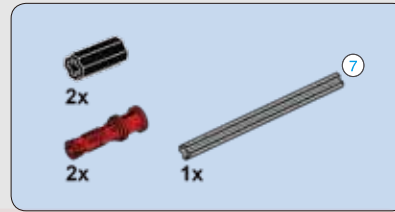
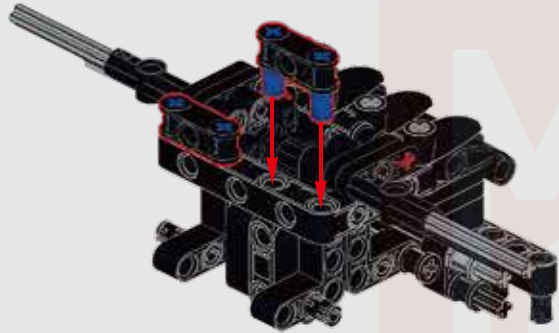

290

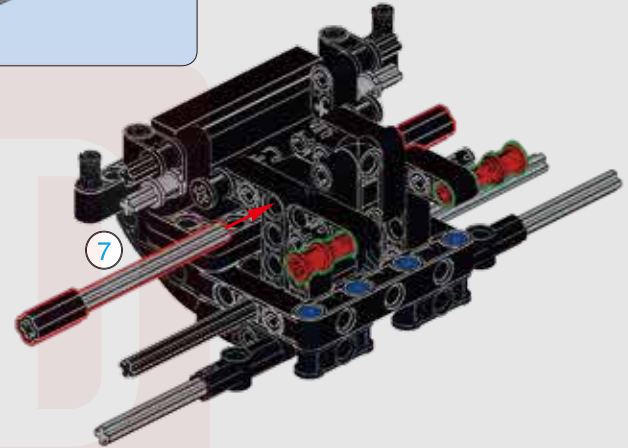

291

注意：拼装说明请参考13090 迈凯伦P1
静态说明第150页473-477步
**Note: Please refer to step 473-477 on page
150 of 13090 McLaren P1 Manual Version
for assembly instructions.**

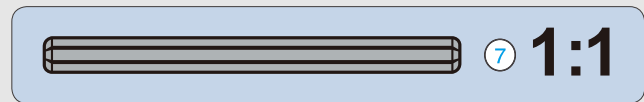
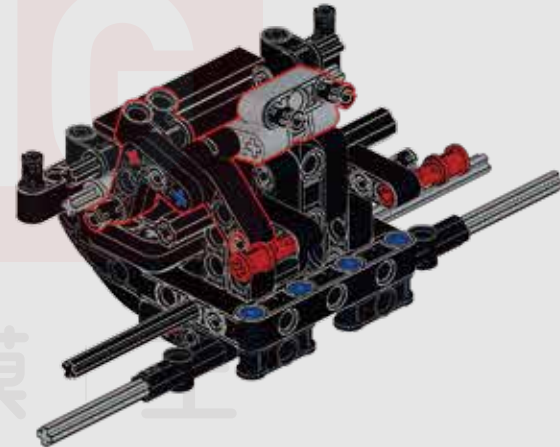



注意：拼装说明请参考13090
迈凯伦P1静态说明第151页
479-485步
**Note: Please refer to step 479
-485 on page 151 of 13090
McLaren P1 Manual Version
for assembly instructions.**

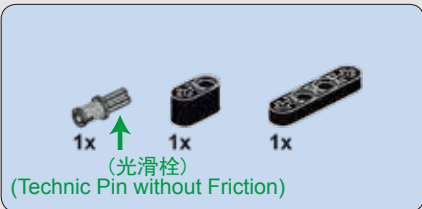

292

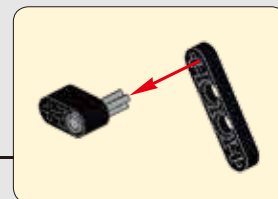
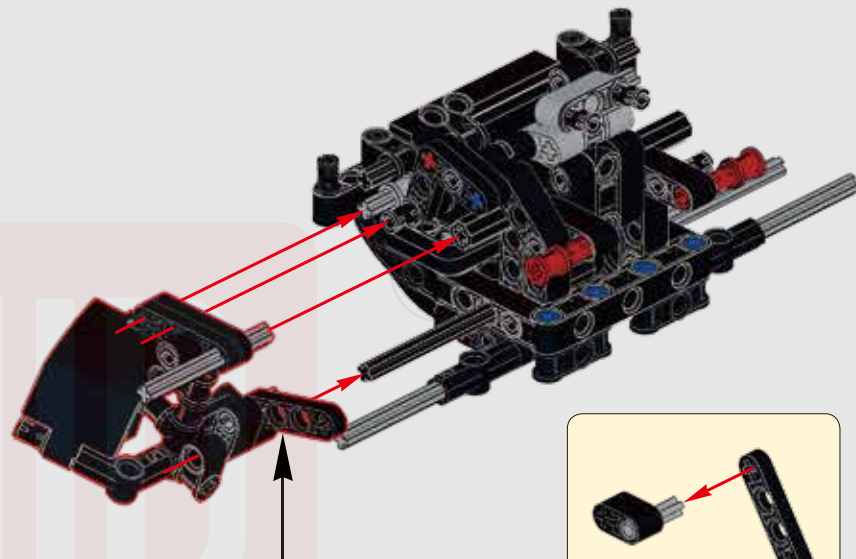
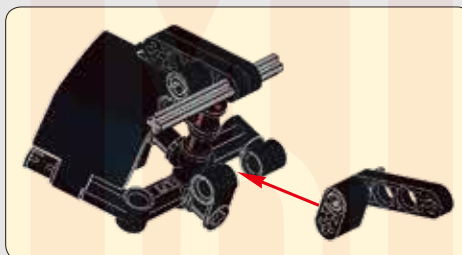

293

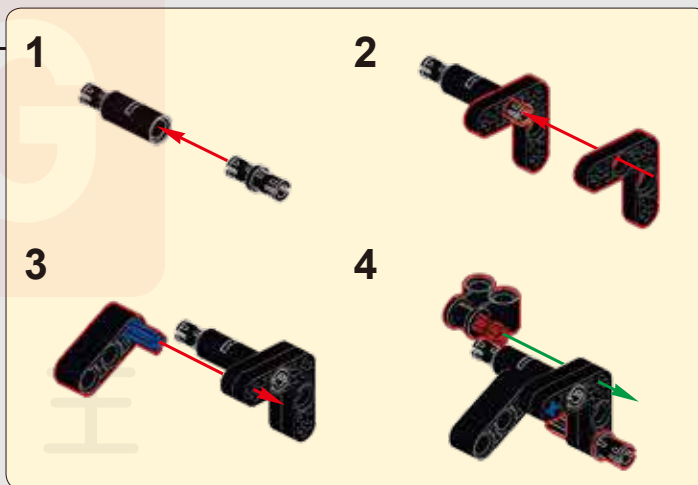
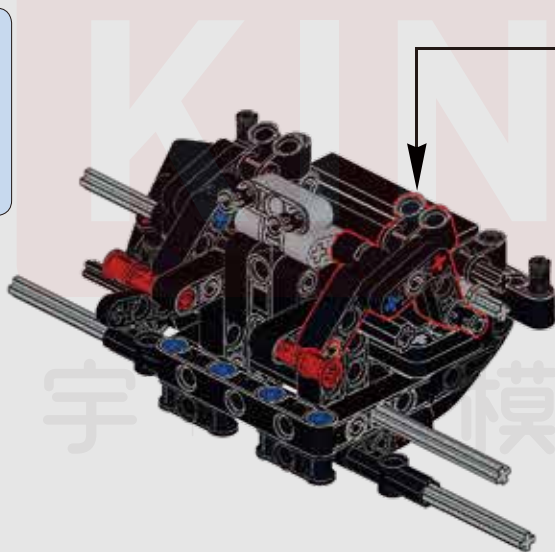



注意：拼装说明请参考13090
迈凯伦P1静态说明第153页
488-494步
**Note: Please refer to step 488
-494 on page 153 of 13090
McLaren P1 Manual Version
for assembly instructions.**



294

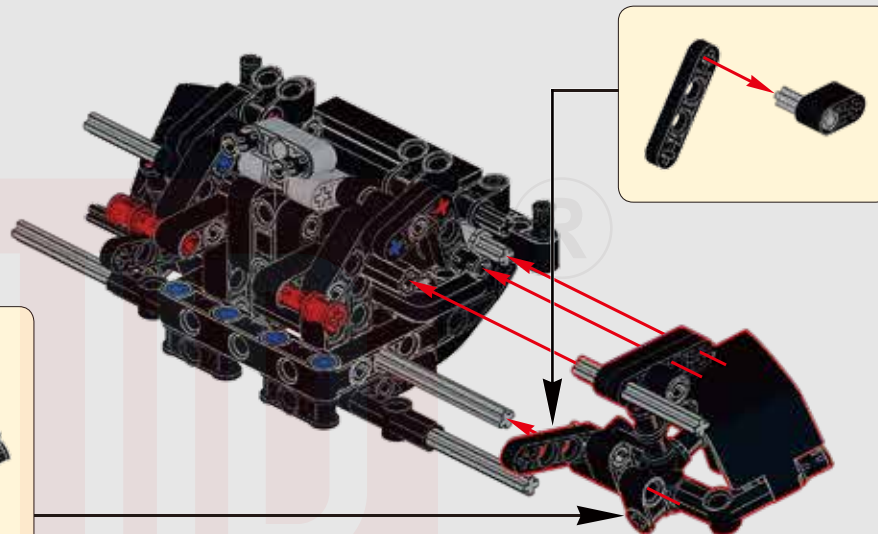
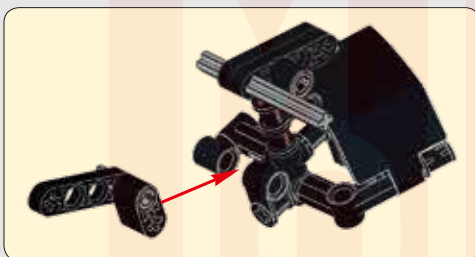

295



注意：拼装说明请参考13090
迈凯伦P1静态说明第154-156页
496-505步 **Note: Please refer to
step 496-505 on page 154-156
of 13090 McLaren P1 Manual
Version for assembly instructions.**

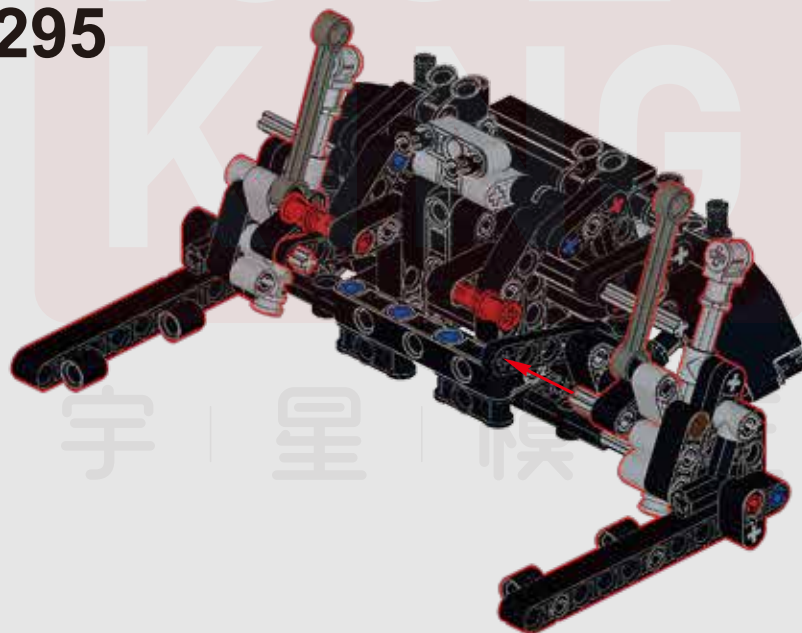

注意：拼装说明请参考13090
迈凯伦P1静态说明第156-157
页506-515步 **Note: Please
refer to step 506-515 on
page 156-157 of 13090
McLaren P1 Manual Version
for assembly instructions.**

296



注意：拼装说明
请参考13090 迈
凯伦P1静态说明
第158页517-521步

Note:Please refer to step 517
-521 on page 158 of 13090
McLaren P1 Manual Version for
assembly instructions.

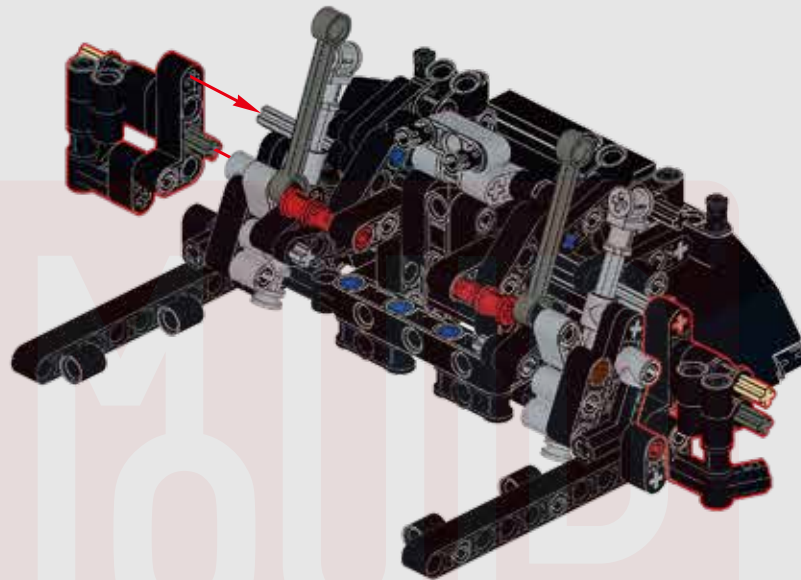

注意：拼装说明
请参考13090 迈
凯伦P1静态说明
第159页522-
526步

Note:Please refer to step 522
-526 on page 159 of 13090
McLaren P1 Manual Version for
assembly instructions.



注意：拼装说明请参考13090 迈
凯伦P1静态说明第160页528步

Note:Please refer to step 528
on page 160 of 13090 McLaren
P1 Manual Version for assembly
instructions.

297

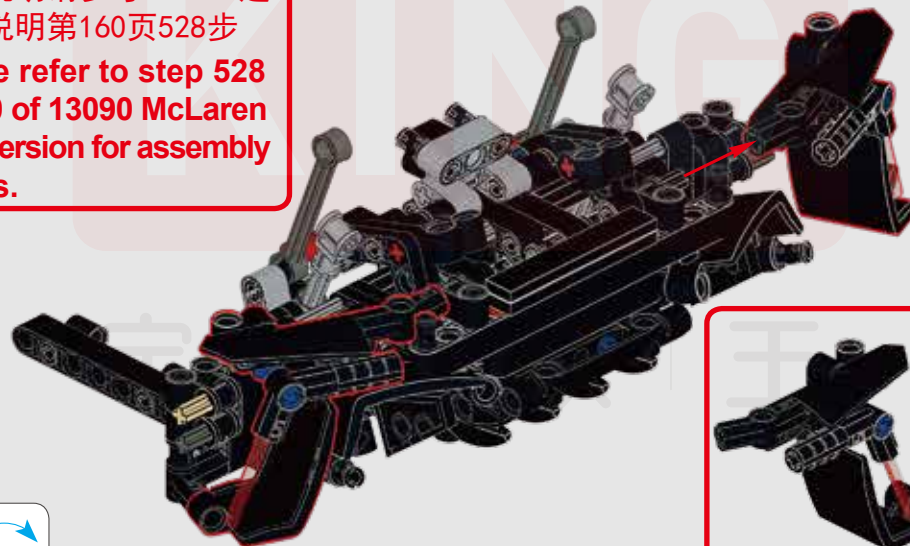

注意：拼装说明请参考13090迈
凯伦P1静态说明第160页528步

Note:Please refer to step 528
on page 160 of 13090 McLaren
P1 Manual Version for assembly
instructions.



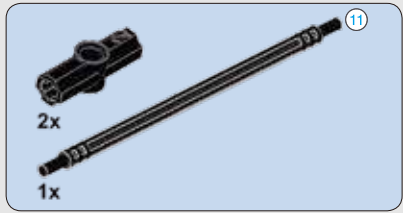

298

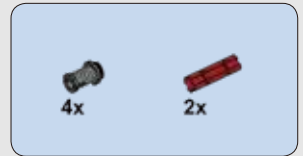
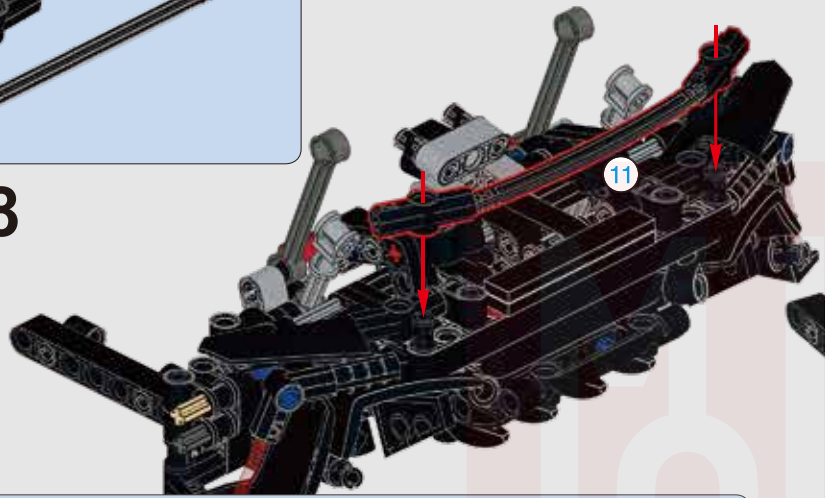

299

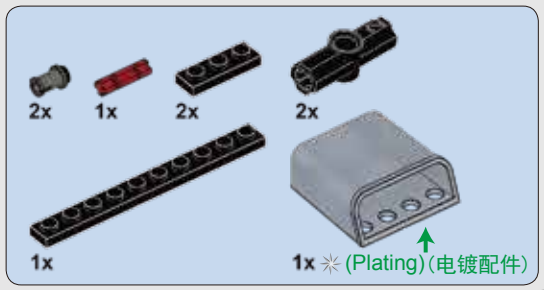
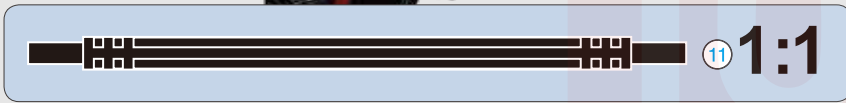
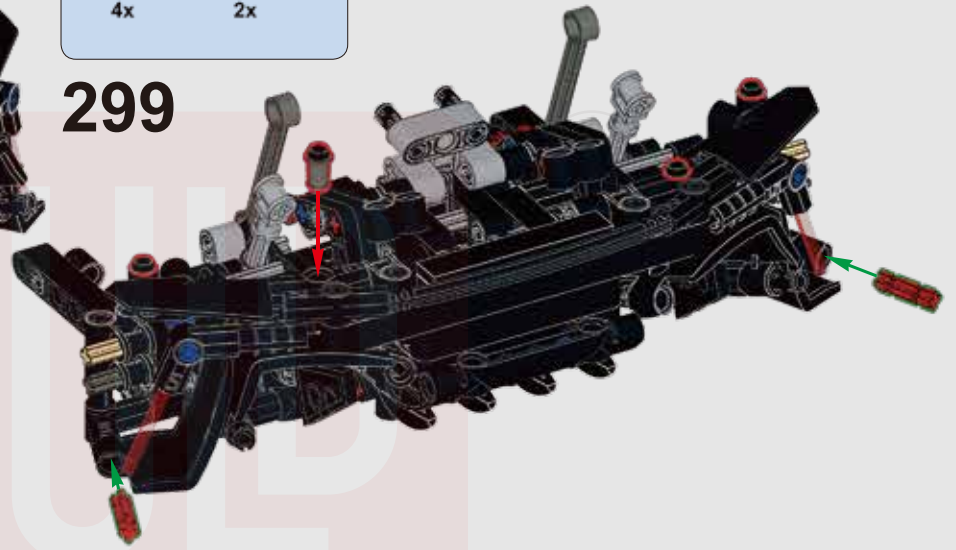

300

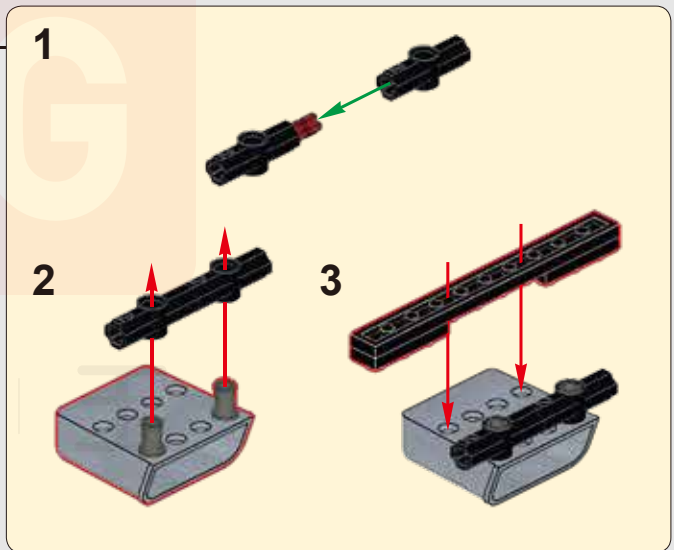
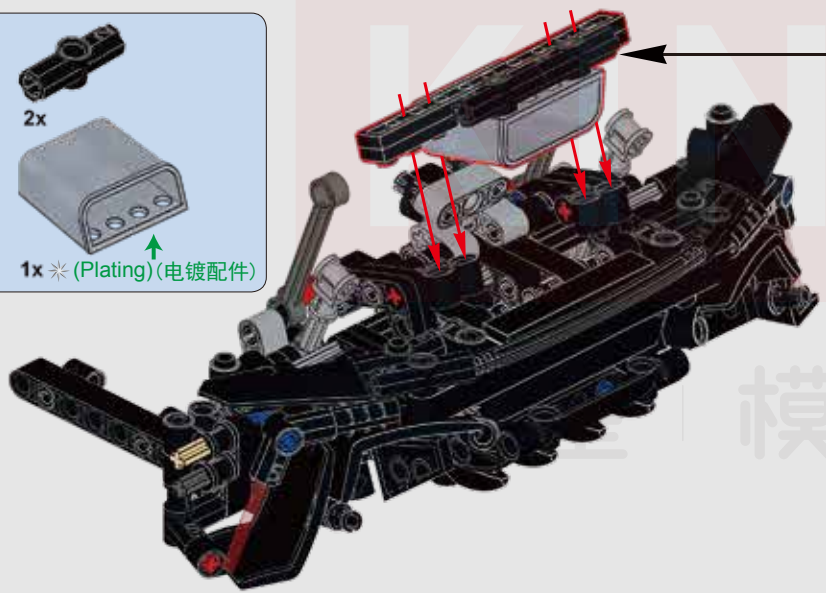

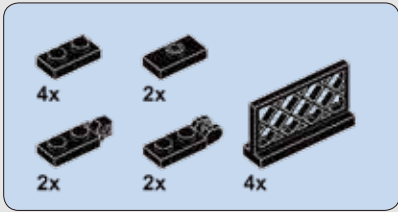

301

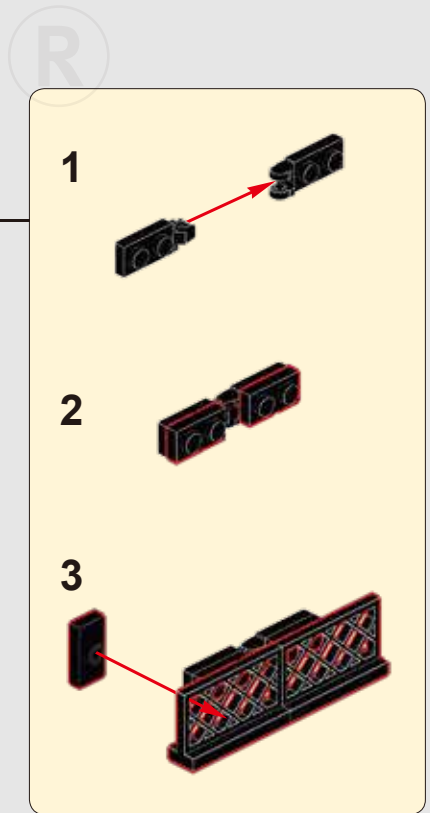
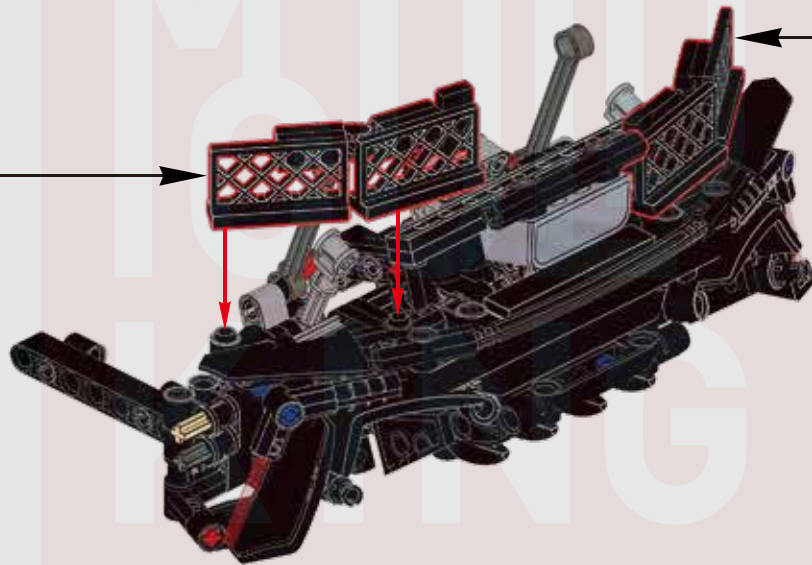
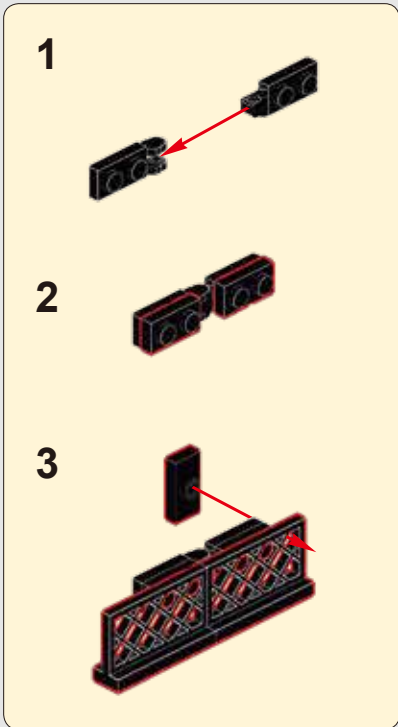

宇 | 星 | 模 | 王



302

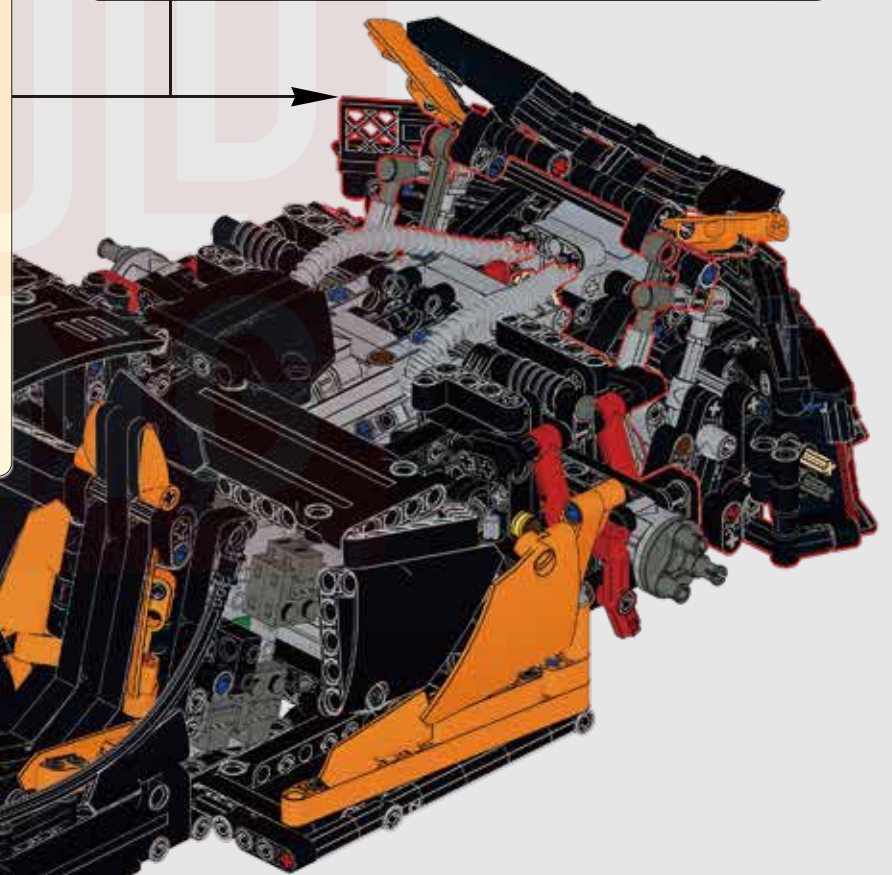
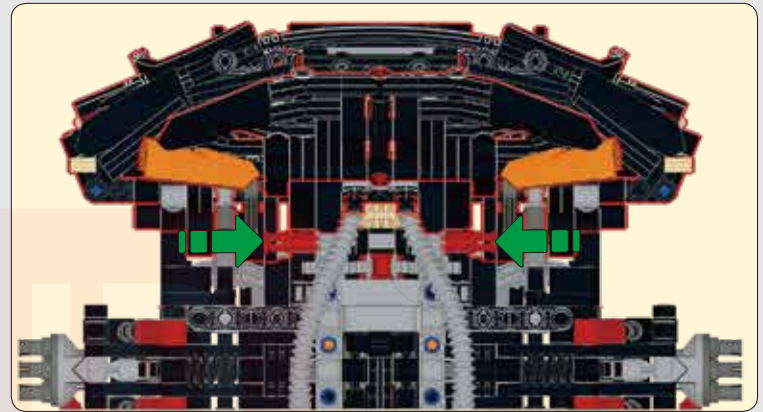
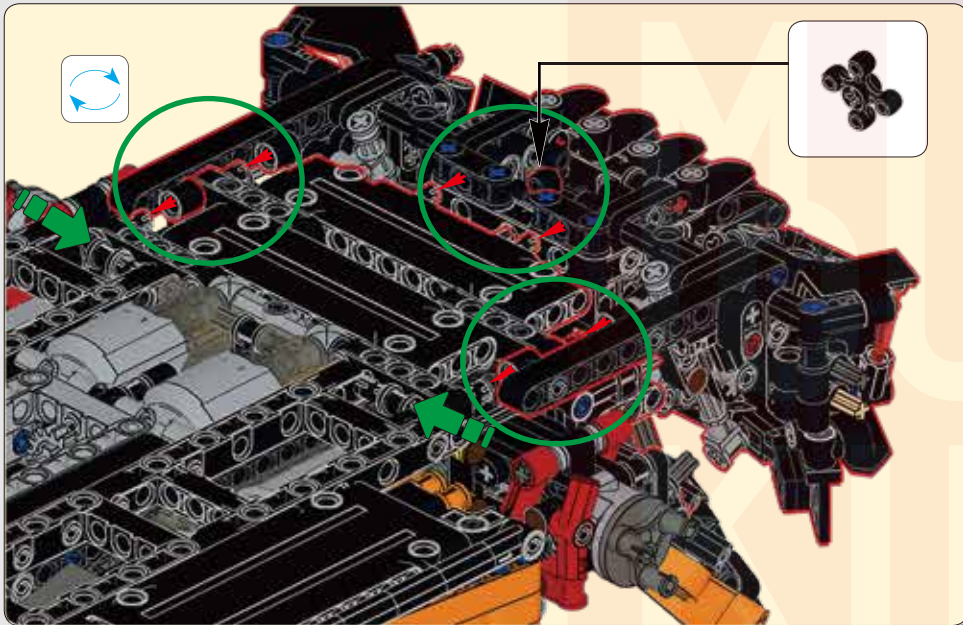

303

注意：拼装说明请参考13090
迈凯伦P1静态说明第164-169页534-555步

**Note: Please refer to step 534-555
on page 164-169 of 13090 McLaren
P1 Manual Version for assembly
instructions.**

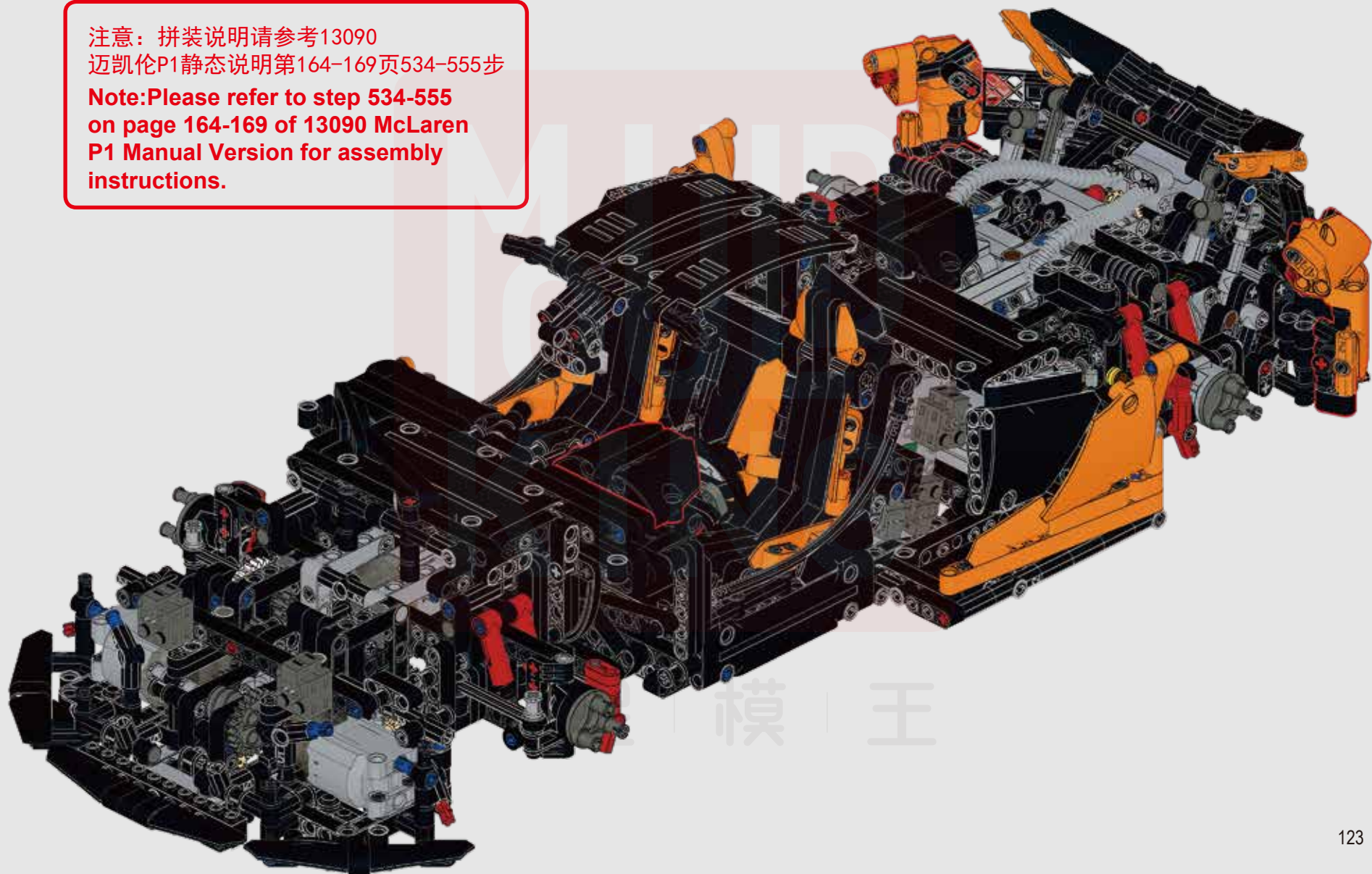

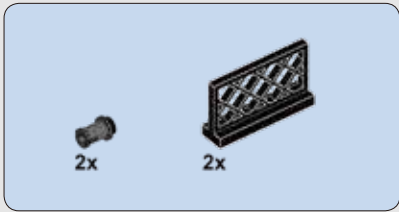

304

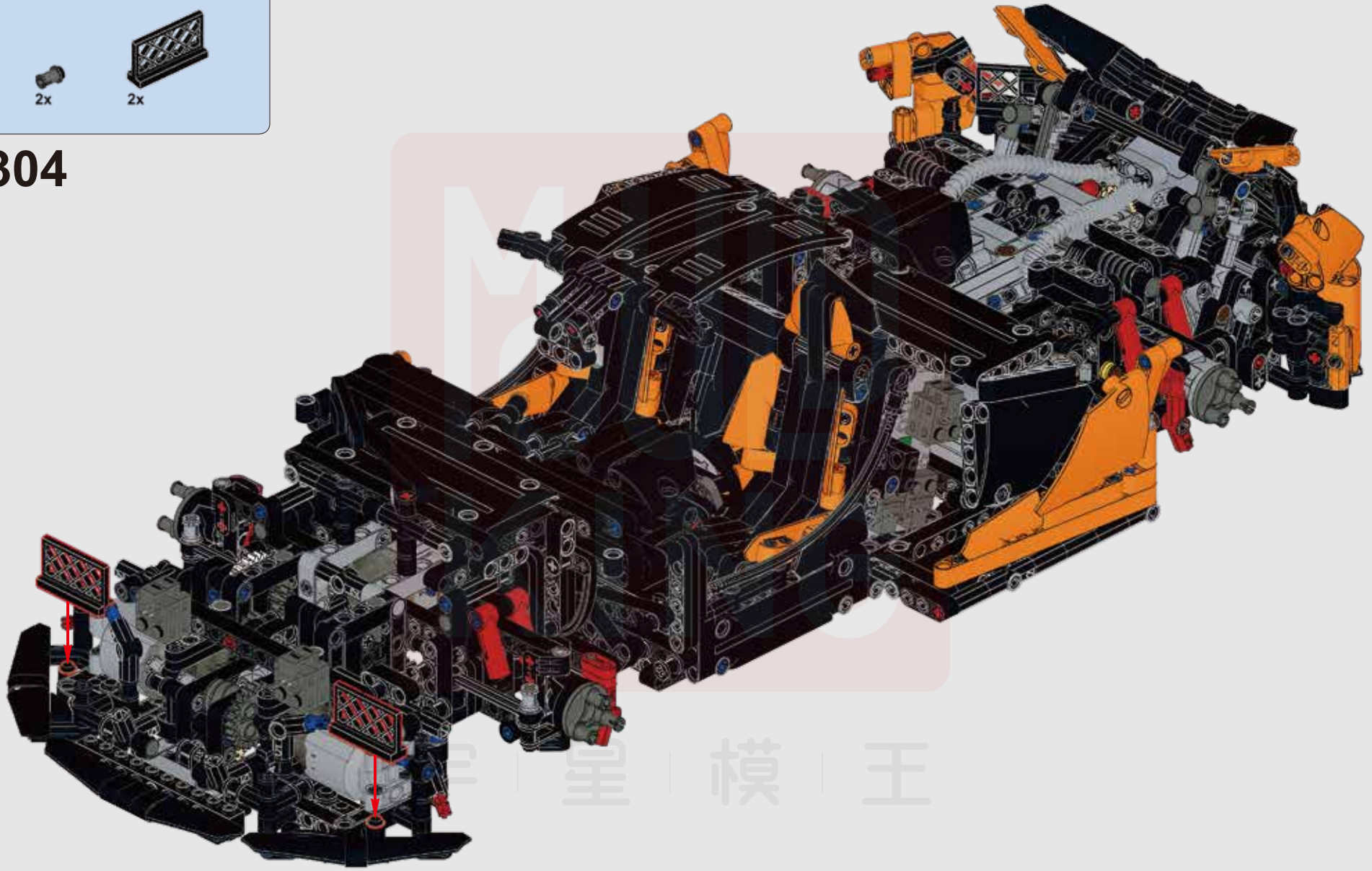

305

注意：拼装说明请参考13090迈凯伦P1静态说明第171-247页557-815步(请忽略631和640的黑色三孔轴)

Note: Please refer to step 557-815 on page 171-247 of 13090 McLaren P1 Manual Version for assembly instructions. (please ignore the black three hole shaft of 631 and 640)

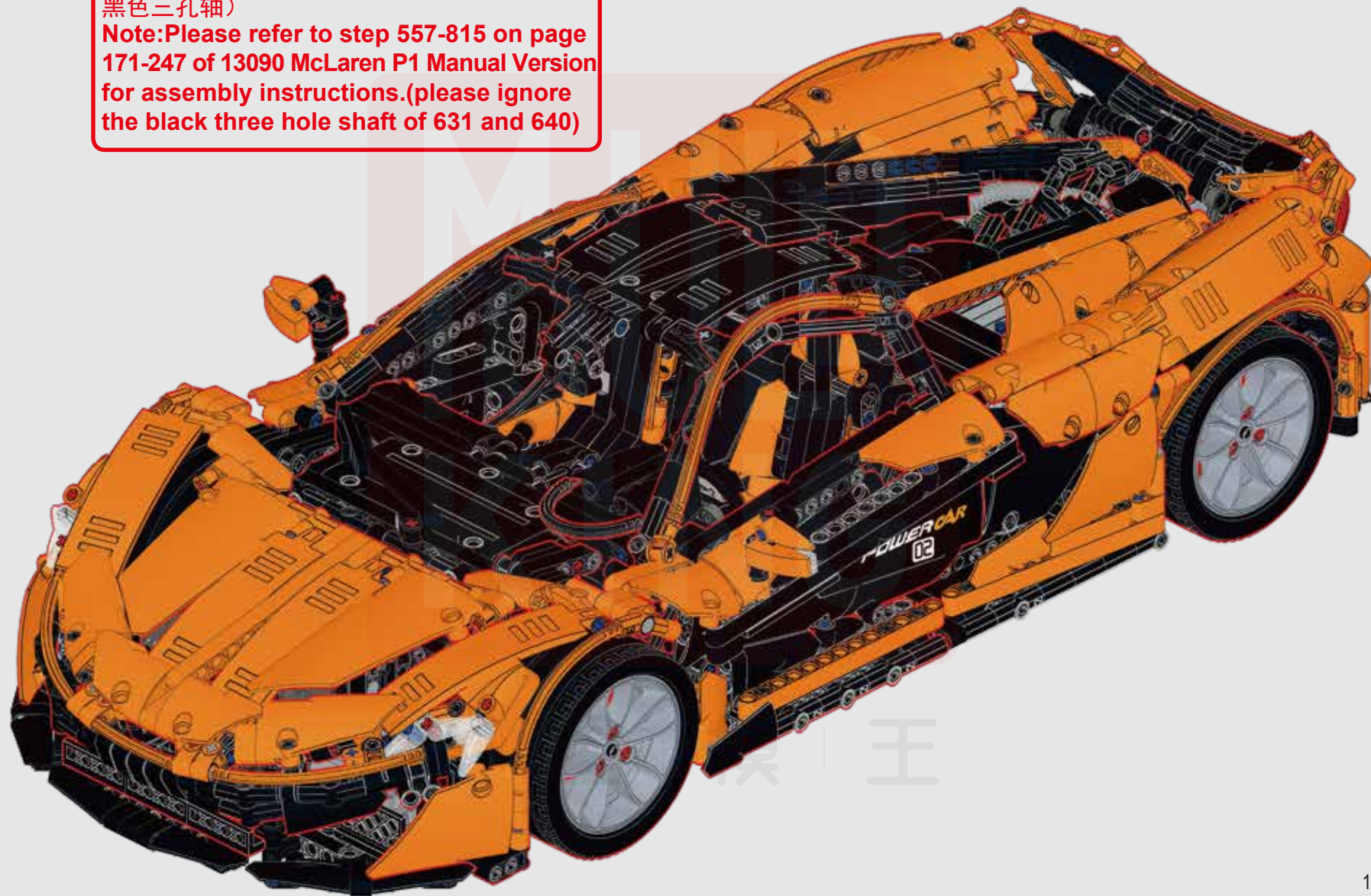

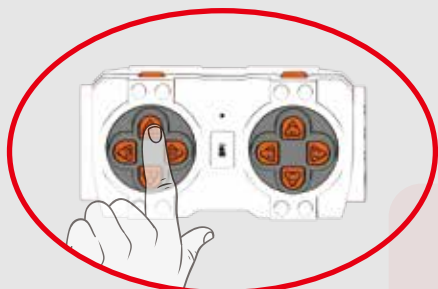

低速挡
Bottom gear

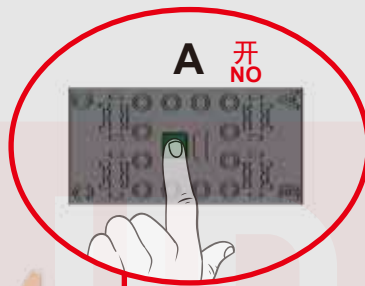

A 开
NO

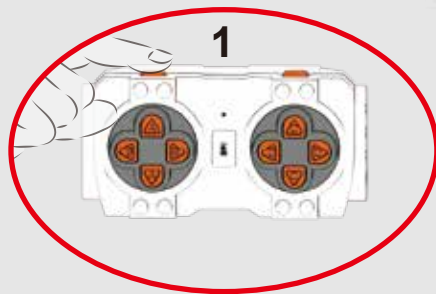
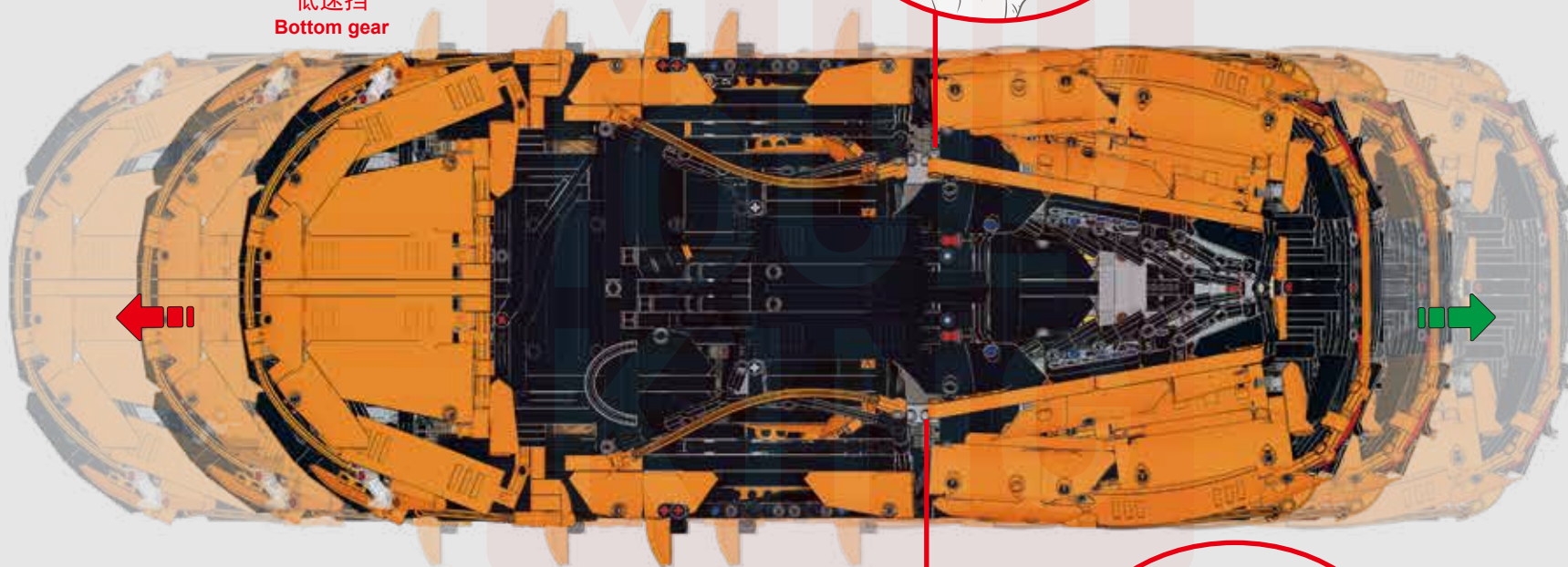

1

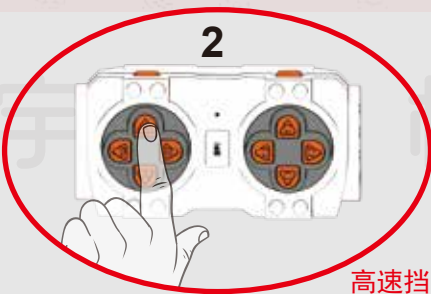

2

高速挡
Top gear

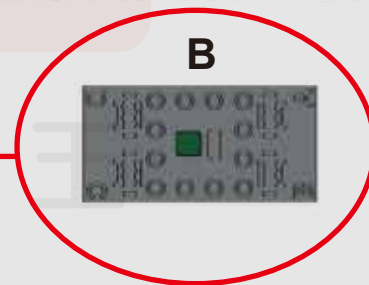

B

307

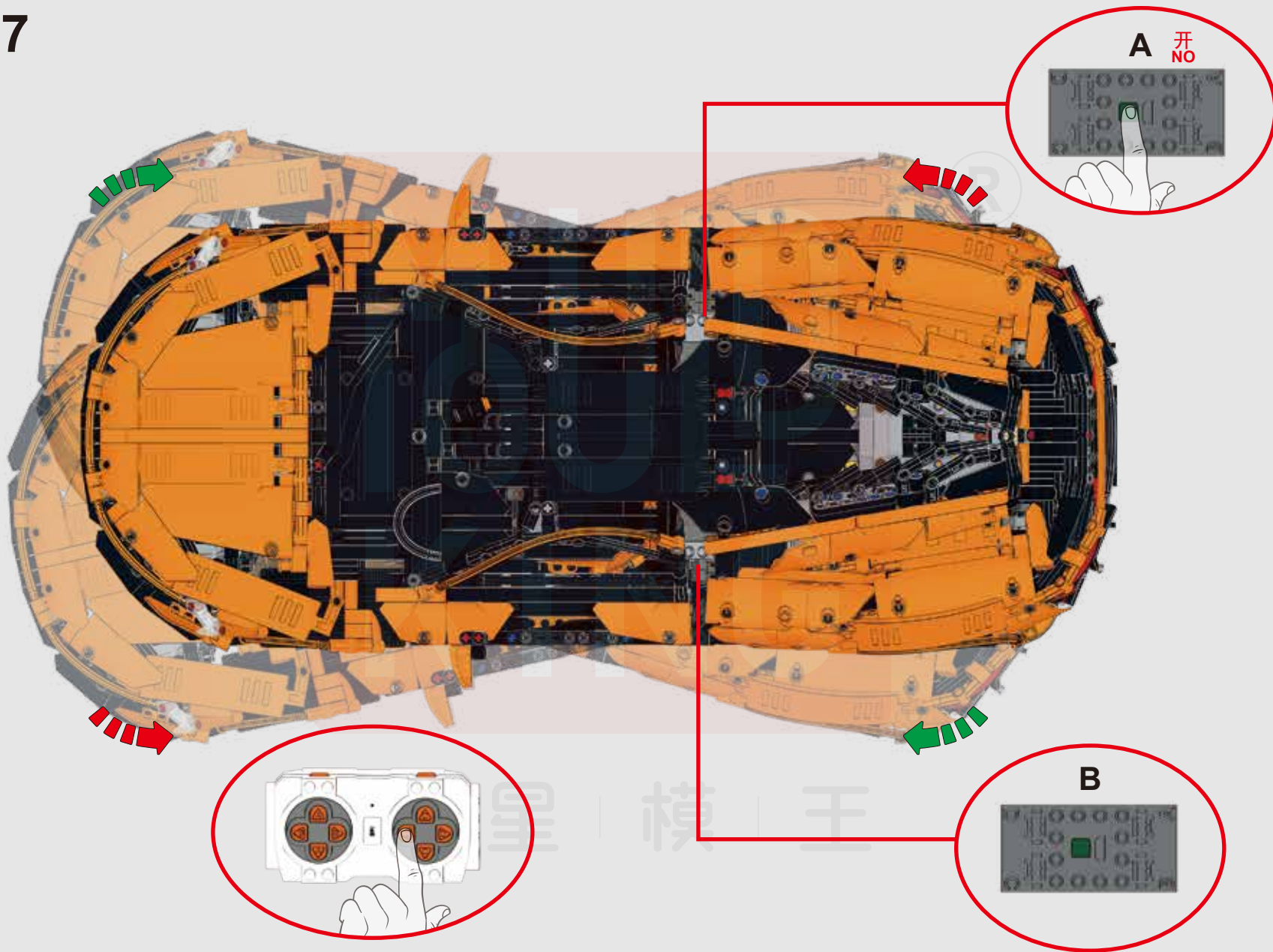

308

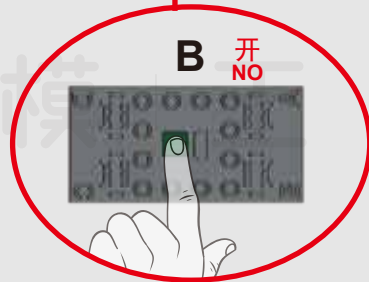
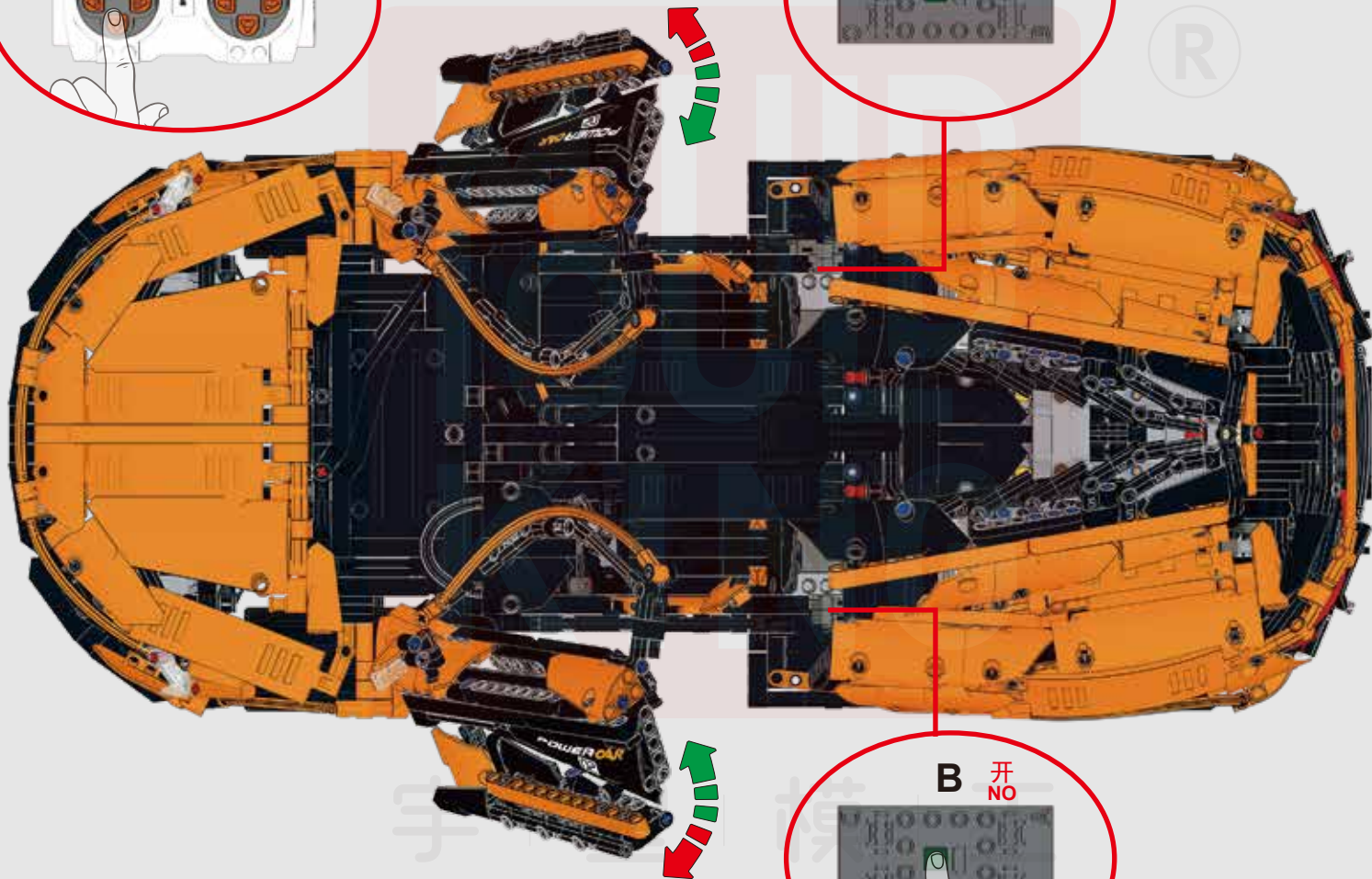
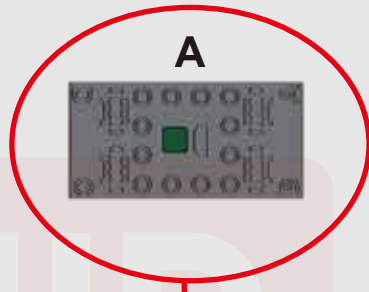
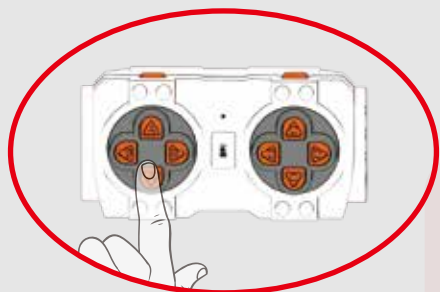

309

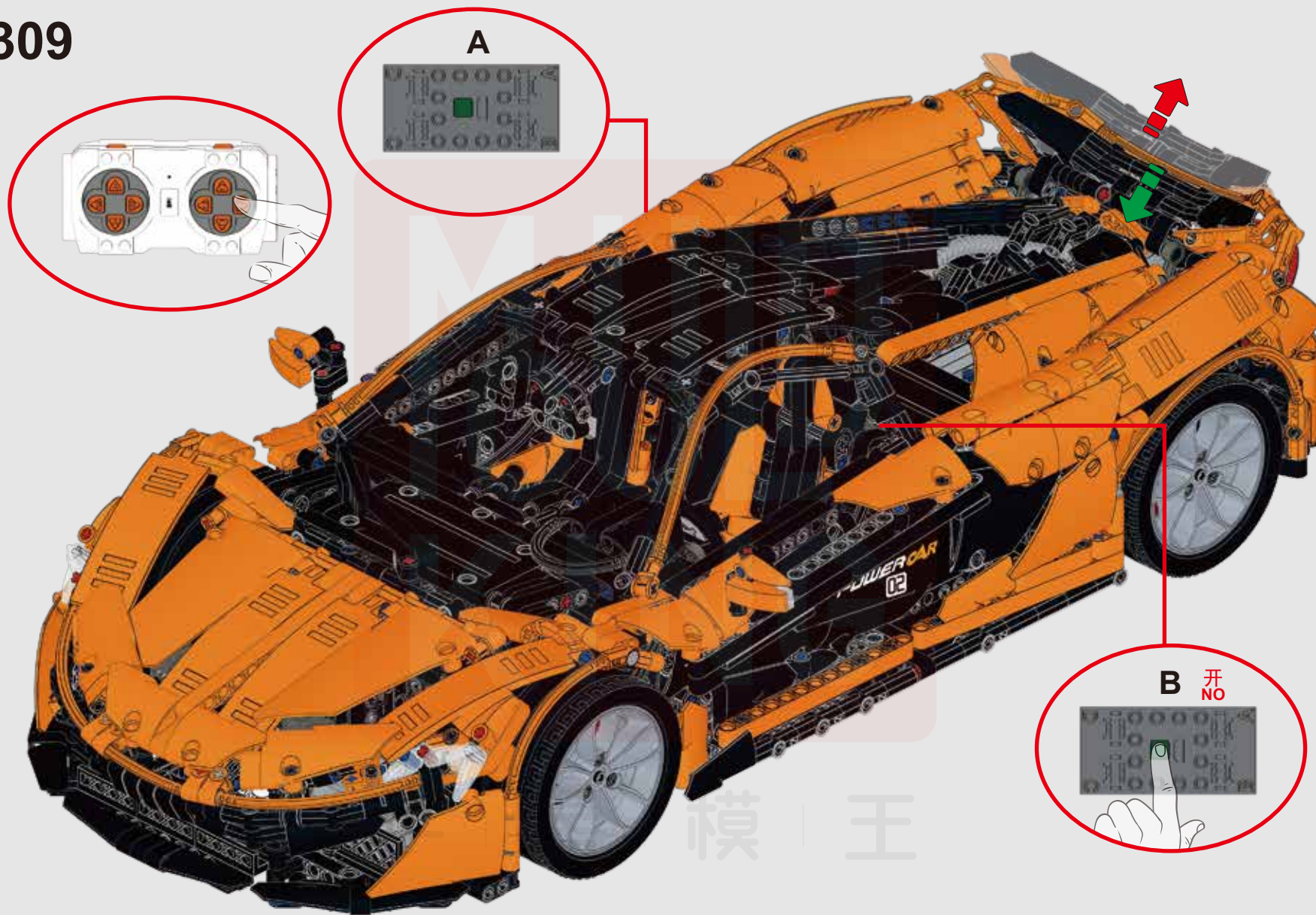

310

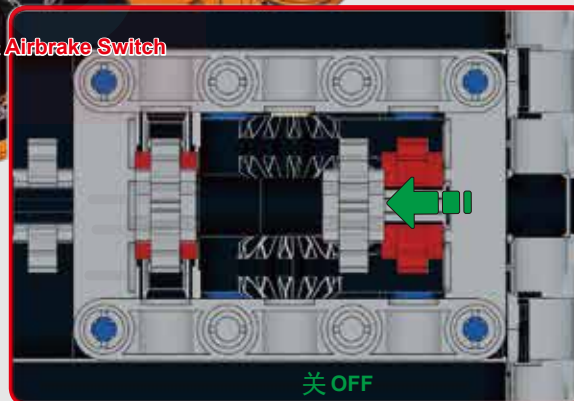
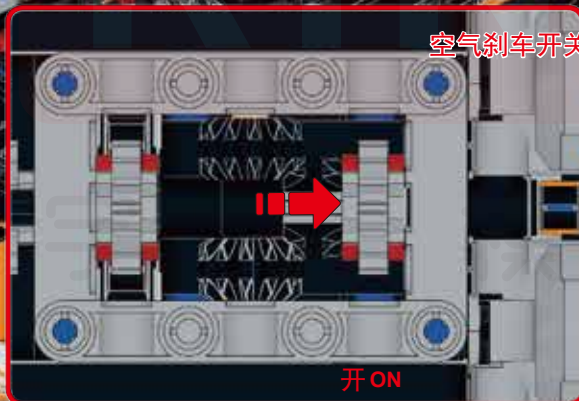
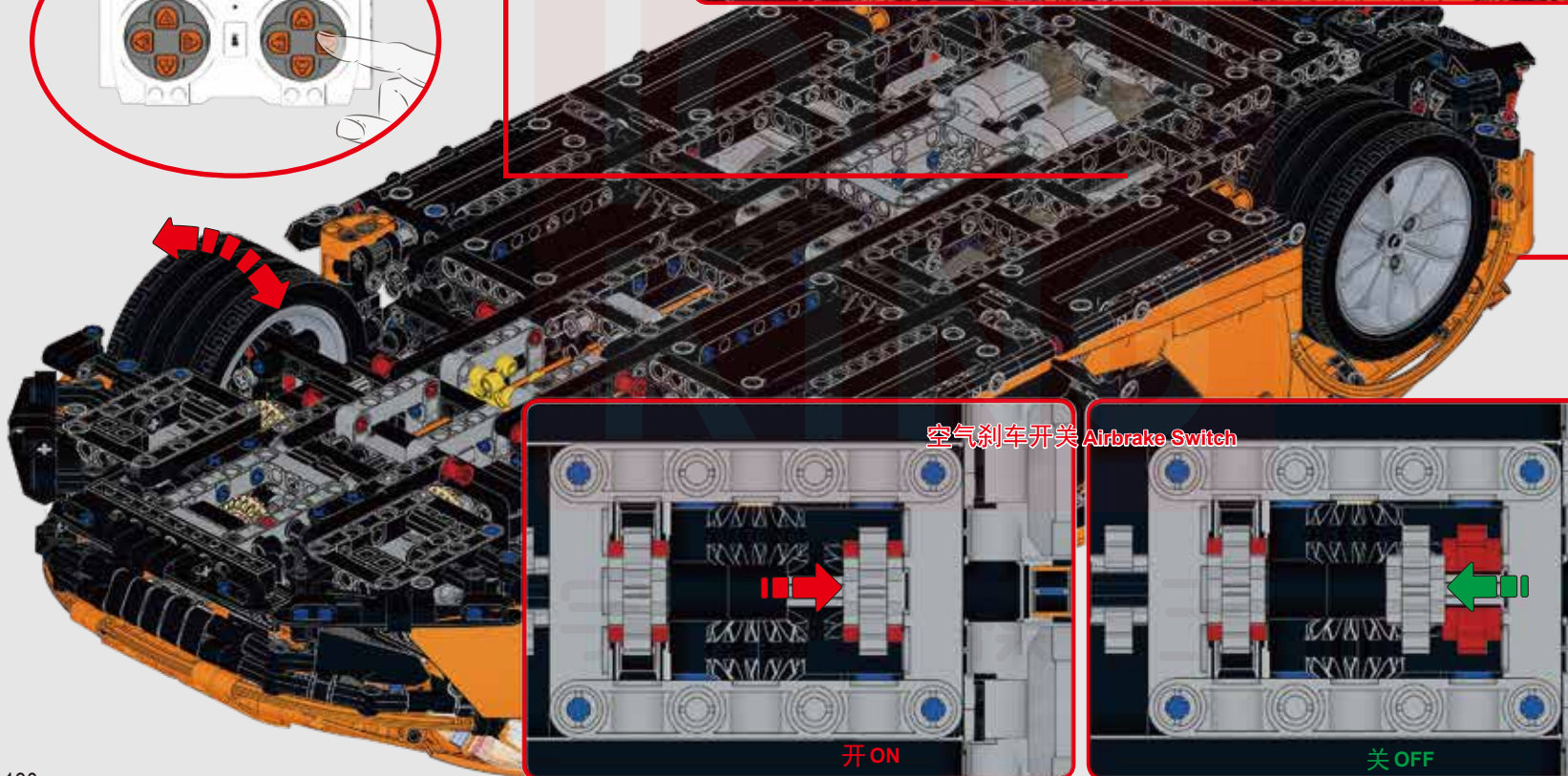
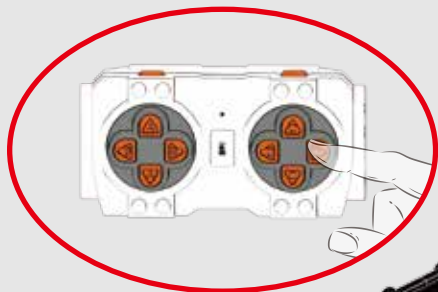
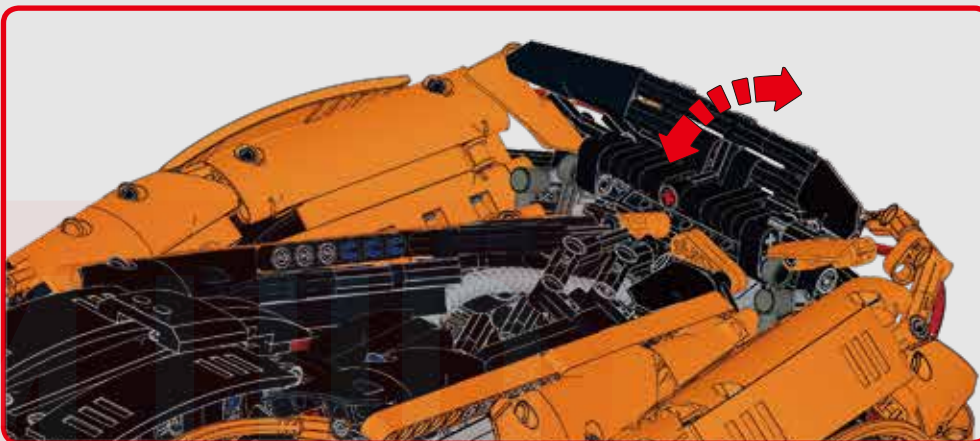
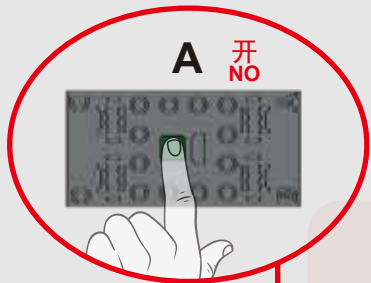

311

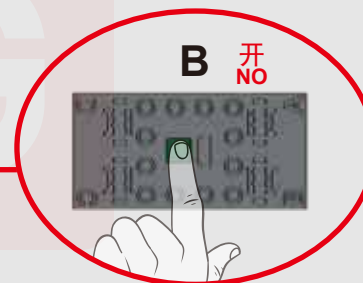
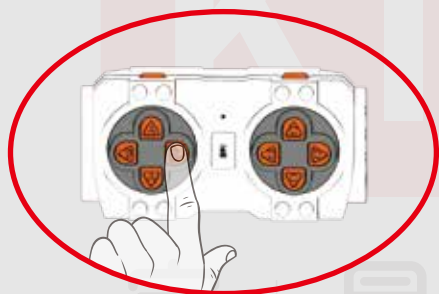
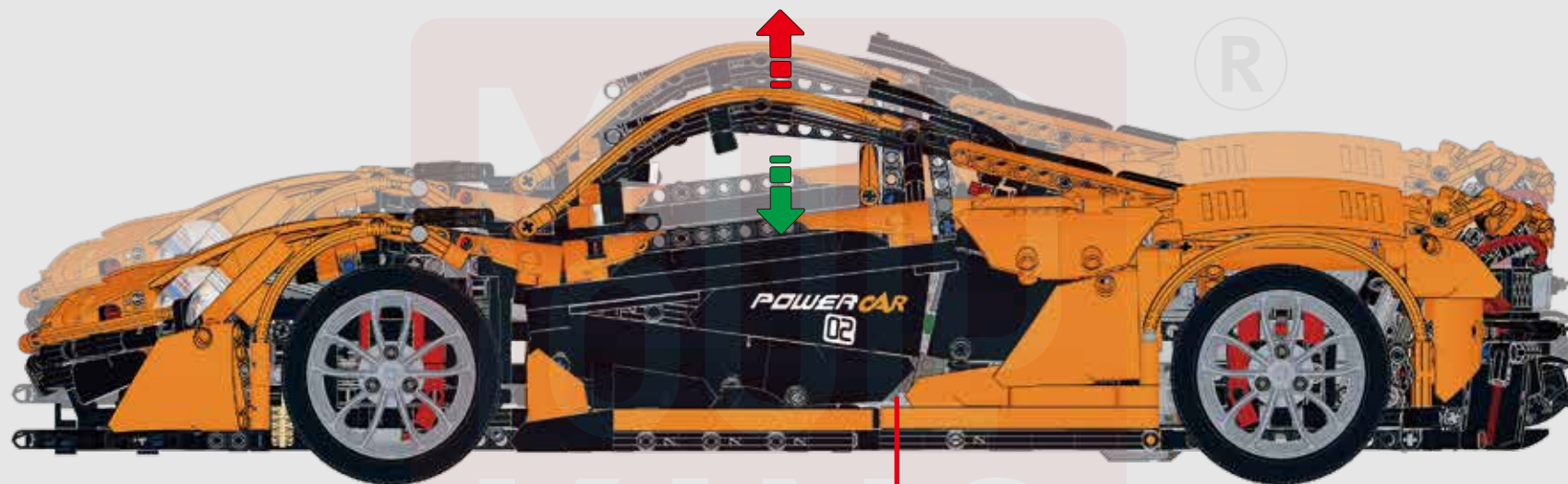

手 | 星 | 模 | 王

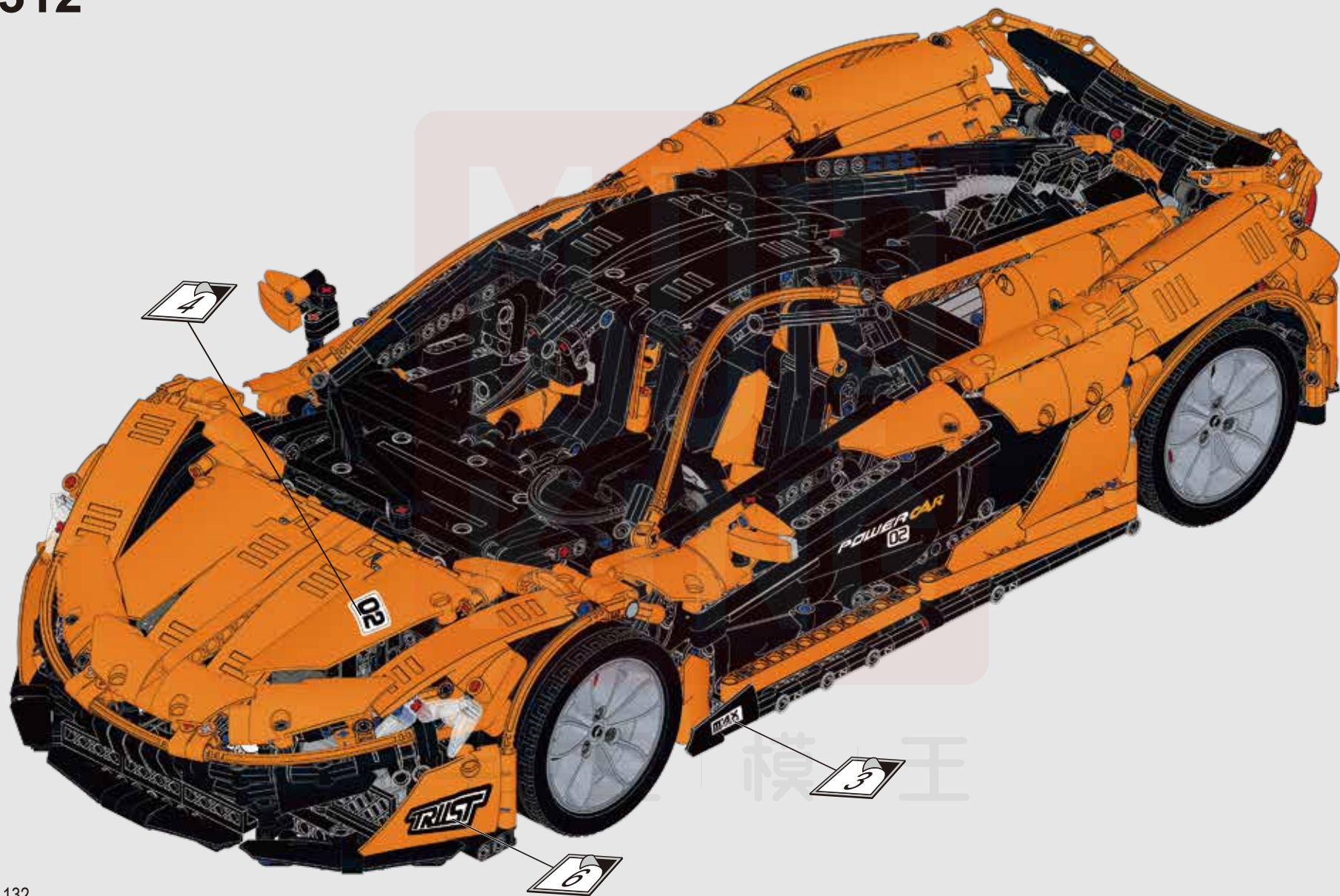

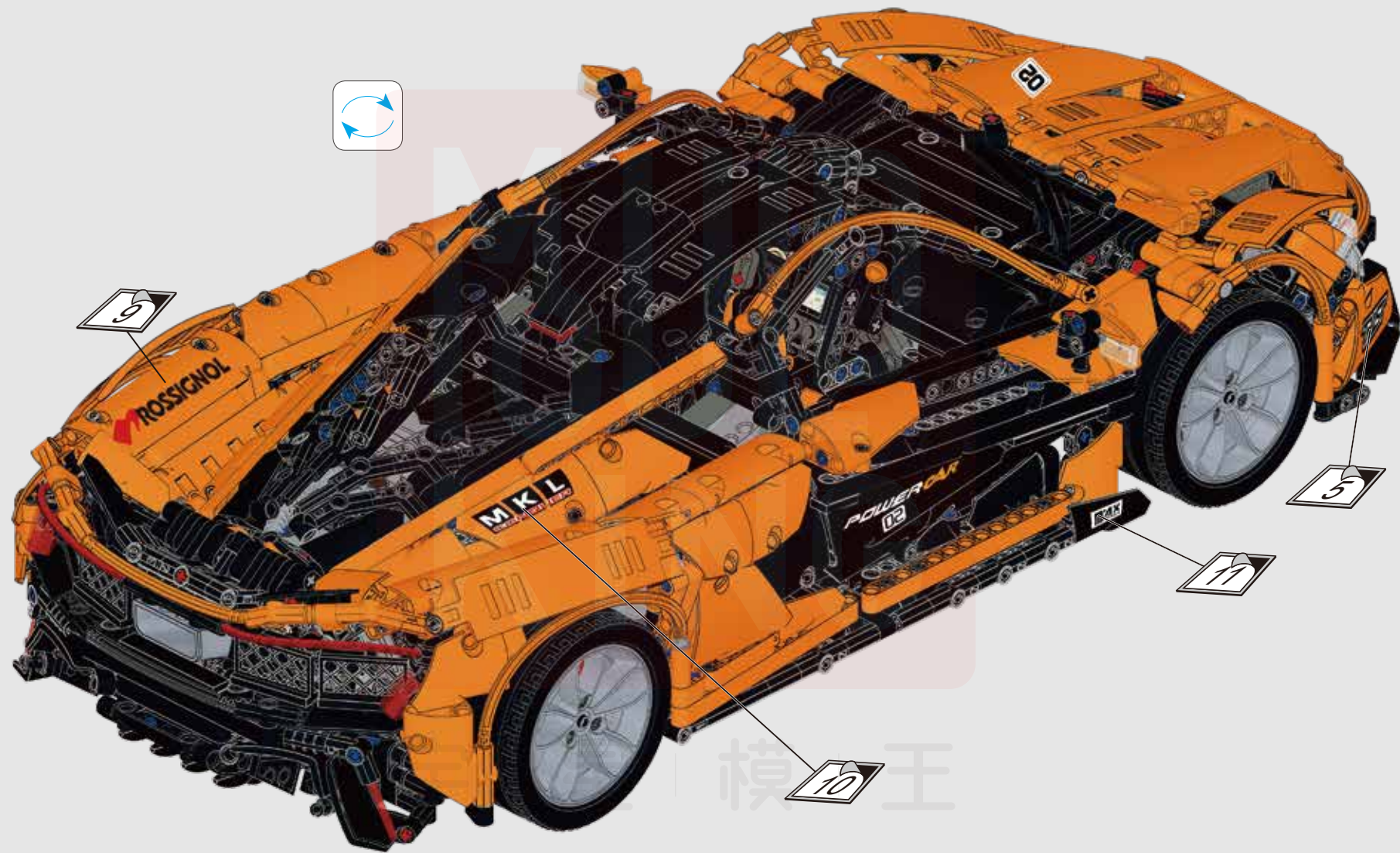



星 | 模 | 王



MULD

®

主 | 模 | 王

