

■ Before you begin operation, please read this manual to understand the function of the product. Failure to operate correctly may break the product or cause serious damage to persons and property. This product is a model, not a toy. You must not only operate it carefully, but also have the common knowledge and foundation to operate it. Failure to use this product safely can destroy the product or cause personal injury to you, as well as other property damage. The use of this product by children is permitted only under the supervision of an adult. This manual includes safety, operation, and maintenance. Therefore, before assembling, installing, or using the product, it is important that you read and follow all tips and warnings in the manual so that you can operate it properly and avoid causing damage or serious injury.

1. Age recommendation: not suitable for children under 14 years old, as this is not a toy.
2. Please always operate your model in an open space and away from vehicles, traffic and people.
3. Operating instructions and warnings must be followed, including the use of optional equipment. (Chargers, optional rechargeable batteries, etc.)
4. Always keep away from all chemicals, small parts and electrical equipment that need to be kept out of reach of children.
5. Water contact should be avoided; this device is not waterproof; water vapor can also cause damage to electronic products.
6. It is forbidden to put any part of the model in one's mouth, because it may lead to serious injury or even death.
7. Do not continue to operate your model when the battery voltage of the remote control is too low.
8. Do not look directly at the light-emitting diode beam to avoid damage to your eyes.
9. During and after the flight, the motor and electronic components will generate high temperatures, please do not touch them to avoid burns.
10. Please do not touch the high-speed rotation of the blades to avoid damage.



Note: The charger packaged with the C159 can be used for safe charging and we recommend that you use the original USB charger. Using other brands of chargers can cause damage to the battery resulting in property damage!

Warnings! Failure to read the following carefully may cause the battery to leak, explode or catch fire.

1. Do not put the battery into the water; store the battery in a cool and dry place when not in use for a long time.
2. Keep the battery out of the reach of children; if a child accidentally swallows the battery, seek medical help immediately.
3. Do not use or store the battery near heat-producing sources, such as fire or heating ovens.
4. When charging, use a charger that meets the specifications.
5. Do not reverse the positive and negative plates.
6. Do not connect the battery directly to a wall outlet or a cigarette lighter in a vehicle.
7. Do not put the battery into the fire or heat the battery.
8. Do not use wires or other metal objects to short-circuit the positive and negative terminals of the battery.
9. Do not transport or store the battery with necklaces, hairpins, or other metal objects.
10. Do not hit or throw the battery, or hit the battery with hard objects.
11. Do not directly weld the battery terminals.
12. Do not pierce the battery casing with nails or other sharp objects, and prohibit hammering or stepping on the battery.
13. Do not disassemble the battery in any way.

Note:The batteries should not be left idle for a long period of time at full charge and low charge, otherwise the batteries will not be charged or will bulge. If the batteries are left for a long time, please charge the batteries to 7.8V first and store them in a dry and safe place.

Length:	260 mm
Height:	80 mm
Weight:	100G
Main Propeller Length:	256 mm
Battery Specification:	7.4V 350mAh
Flight Duration:	Approx. 13-15 mins
Main Motor:	1020
Tail Motor:	0720
Charging Duration:	Approx. 45 mins

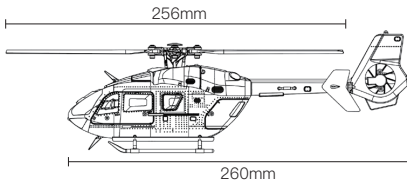

Package List

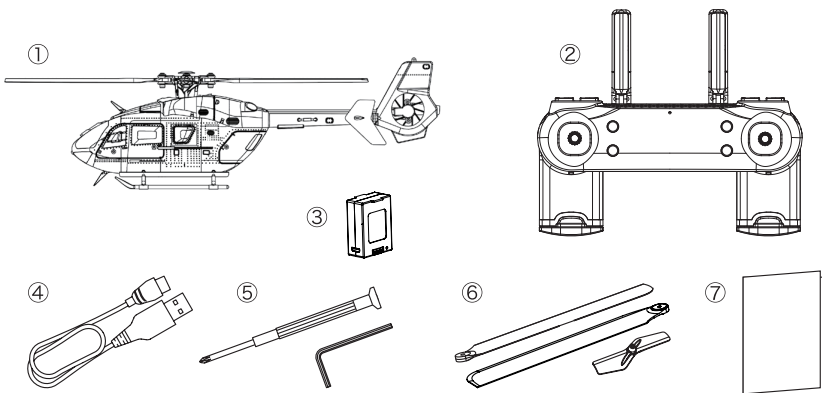

① Helicopter

② Transmitter

③ Lipo battery

④ USB charger

⑤ Phillips screwdriver+hex wrench

⑥ Main Rotor / Tail Rotor

⑦ User Manual

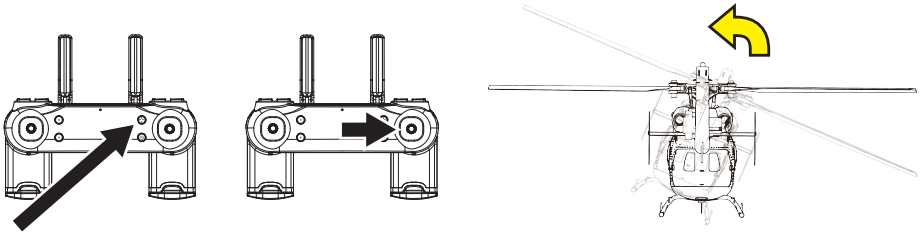
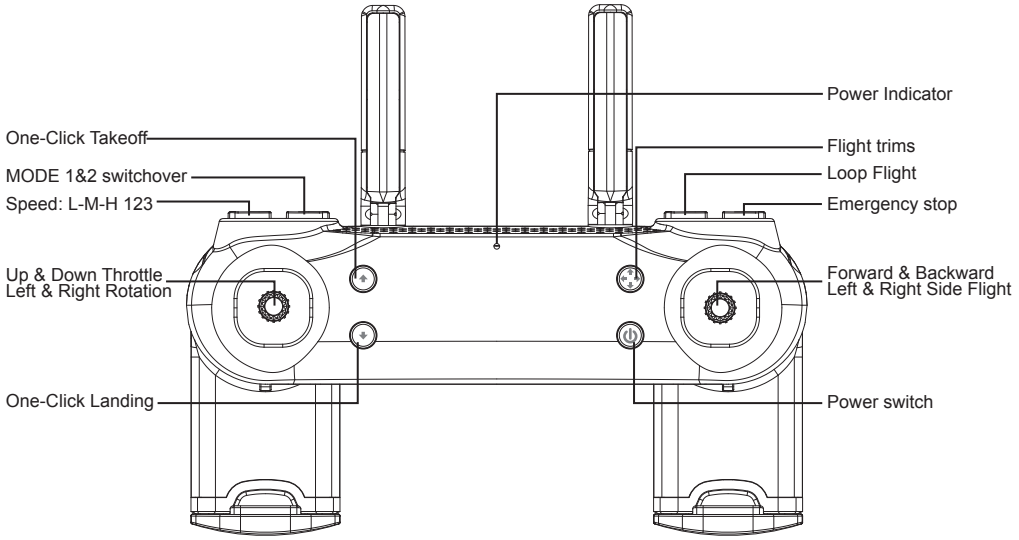

Note: When flight offset occurs.

1. Press and hold the flight trims fine adjustment button for 2 seconds, there will be "di di" sound, then enter the adjustment mode.
2. Toggle the rocker in the opposite direction to adjust the attitude until the flight is smooth.
3. Press the fine adjustment button again to save the data.

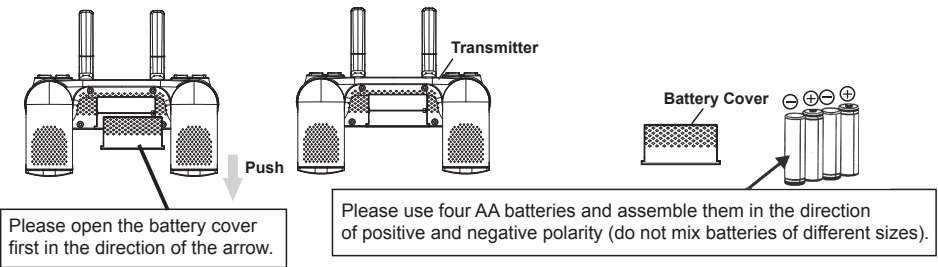

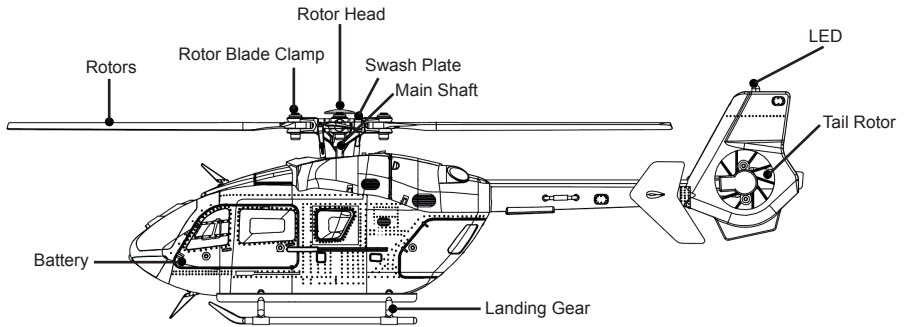

Batteries Charging Method

Charging Method 1:

Use the computer USB port to charge the battery

Instructions:

1. Please use the standard USB charger to connect to the computer port.

Charging - red indicator ON.

Fullled - indicator OFF.

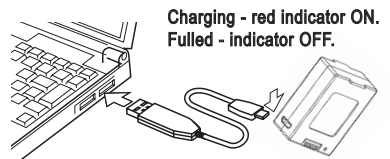

Charging - red indicator ON.
Fullled - indicator OFF.

Charging Method 2:

The phone power adapter is used to charge the battery.

Instructions:

2. Use the standard USB charger to connect the phone power adapter.

Charging - red indicator ON.

Fullled - indicator OFF.

Charging Method 3:

Use the cell phone's mobile power supply to charge the battery.

Instructions:

1. The standard USB charger is used to connect the cell phone's mobile power supply.

Charging - red indicator ON.

Fullled - indicator OFF.

1. Please make sure the battery voltage of both the remote control and the helicopter model is sufficient.
2. A suitable flying site should be far away from crowds, cars, high voltage towers, water pools, etc. to ensure a safe and enjoyable flight.
3. The main rotor fixing screws should not be locked too tightly, and the rotors should be kept folded flexibly, as over-tightening will cause them to vibrate when they cannot be straightened.
4. When you encounter an emergency in flight that cannot be adjusted, you can directly operate the "Emergency Stop" button, long press the button for 3 seconds, and the aircraft will directly stop and rotate to the ground (Note: the operation of this function will have the risk of falling broken)

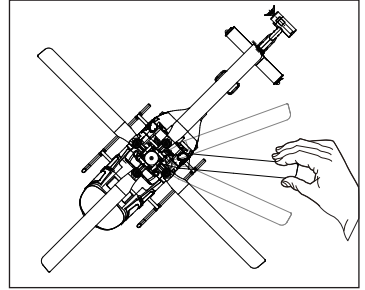

Guidance on Operation Direction

If you are not proficient at controlling the C159, take a few minutes to learn them and then try your first flight.

Throttle

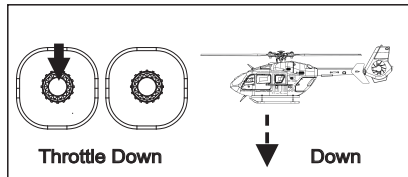
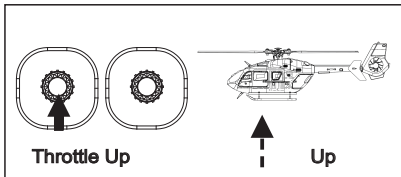

Direction

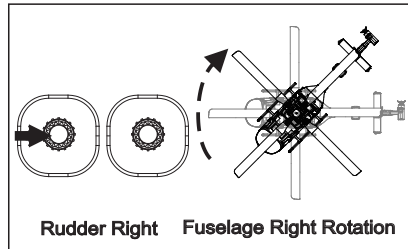
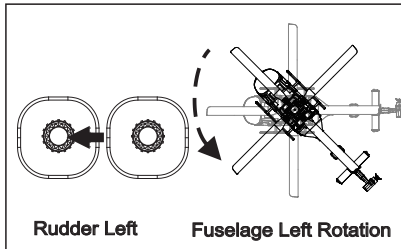

Elevator

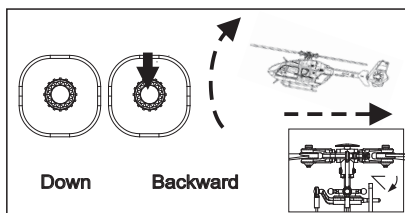
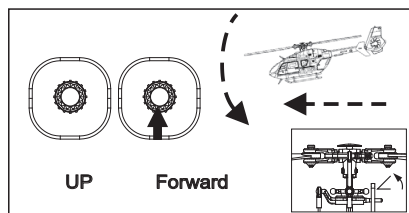

Aileron

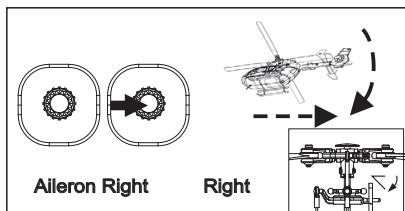
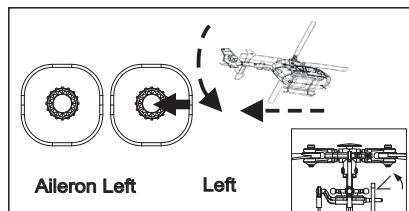

Flight Operation Steps

C159

1. Turn on the remote-control power switch.
2. Remove the nose covering, install the batteries safely into the battery compartment and make sure it is firmly in place, then fix the nose covering, press and hold the power switch for 2 seconds to turn on the power of the aircraft.
3. When the lights of the aircraft and the remote control are flashing at the same time, push the throttle rocker of the remote control up to the bottom and pull it down quickly. When the remote control makes a beeping sound and the aircraft and remote-control lights are on, the code matching is complete.
4. Push the rocker to the trapezoidal angle at the same time to start the aircraft. (You can also press the one-button takeoff to start the helicopter directly)
5. Please keep the head of the aircraft facing forward and keep a safe distance from the helicopter.
6. When manually operating the helicopter to land, please keep the throttle rocker in the down position for 2-3 seconds and wait for the propeller to stop rotating completely before releasing the rocker. (This action is not required to use one button landing).

△ Note: 1. When the helicopter is flying, do not look at the helicopter horizontally to avoid accidental injury.

2. Please make sure there is no working remote control of the same model around when matching the code, so as not to affect the code matching.

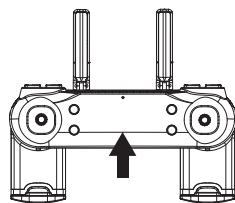

Corresponding to step 1C

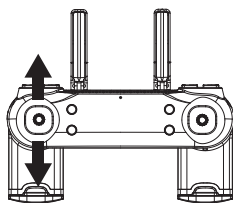

Corresponding to step 3C

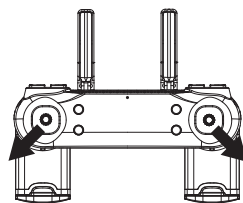

Corresponding to step 4

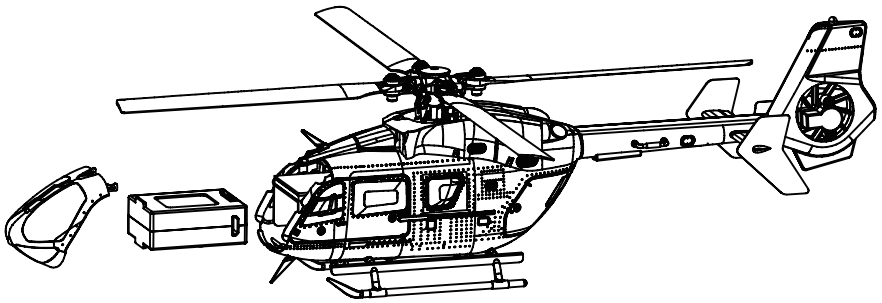

Forward Flight

Keep a safe distance of 2 meters or more.



Note: Beginners should pay attention to the direction of flight, and make sure that the head of the aircraft is pointing forward as much as possible to avoid damage caused by operational errors!

Flight Yaw Correction Methods

C159

If there is flight yaw, it can be corrected by directly toggling the fine adjustment button. The product you have purchased has been set before shipment. If you are not satisfied with the aircraft hovering or the aircraft still has a yaw, you can adjust it by the following settings. Control the throttle of the aircraft to take off, and according to the current yaw direction, toggle the fine adjustment button in the opposite direction until the aircraft can hover smoothly.

<p>Helicopter yawing forward or backward</p>			<p>Fine adjustment according to the direction of the arrow</p>
<p>Helicopter yawing left or right</p>			<p>Fine adjustment according to the direction of the arrow</p>
<p>Helicopter yawing sideways</p>			<p>Fine adjustment according to the direction of the arrow</p>

Notes on Correcting Flight Yaw

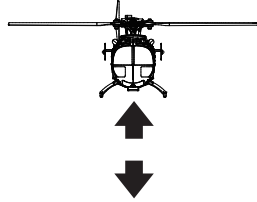

Warning
Please keep a height of more than one meter.

Introduction of the socket corresponding to the receiver

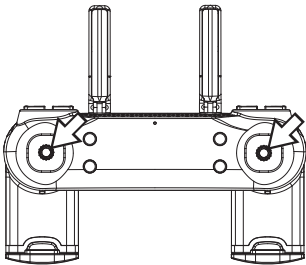
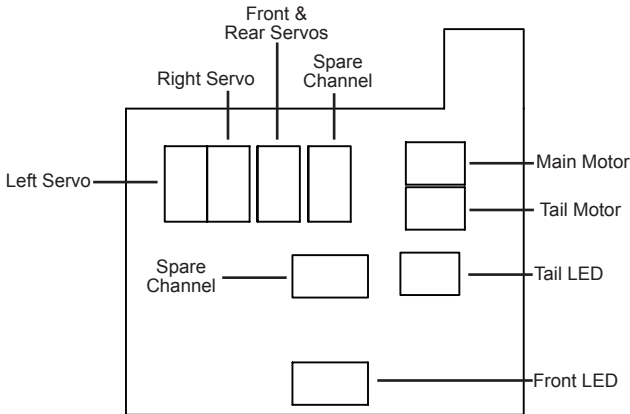

Gyroscope Calibration Methods

1. When the flight is yawed, you can try to land the plane first and then calibrate the gyroscope.
2. When calibrating the gyroscope, you need to place the aircraft horizontally and the ground should not be skewed.
3. When calibrating, the indicator light will flash rapidly, and the indicator light will be on when calibration is finished, then take off again.

The propeller is removed by using a hex wrench; when a new propeller is installed, note that the propeller should not be too tight and make sure it can turn flexibly.

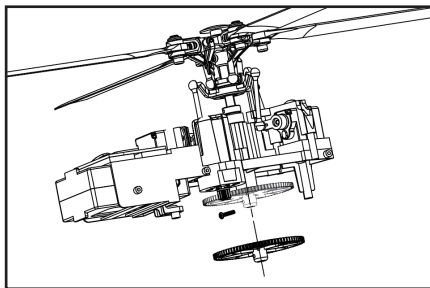
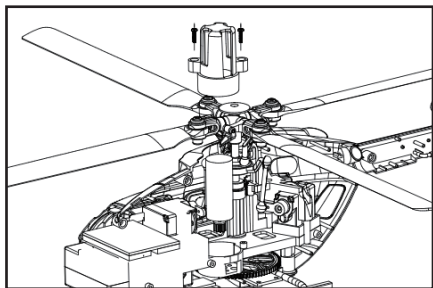
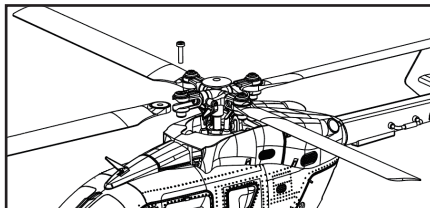

Remove the plug first, then remove the motor base and take out the motor.

Withdraw the screws first, then pull the large gear straight out downward. Pay attention to the direction when installing the new gear, the shaft plane should be aligned with the hole plane inside the gear.

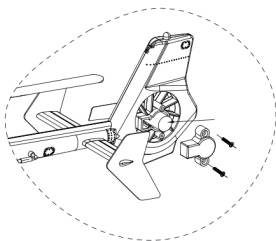
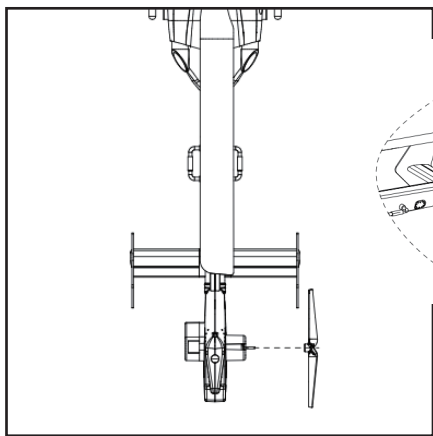

To remove and replace the tail motor, first, remove the tail motor and tail rotor, unplug the motor, and then install the new motor. After installation, make sure the tail motor and tail rotor are installed, and please pay attention to the tail rotor installation direction!

When removing and replacing the tail rotor, please pay attention to the direction and press the motor shaft slowly to ensure a smooth rotation.

	Problem	Cause	Solution
1	Turn on the power switch of the helicopter, the tail light keeps flashing, and the operation is not responsive.	Transmitter-receiver code matching failed.	Please perform the transmitter-receiver code matching again.
2	No response from the helicopter after turning on the power switch.	Please check if the transmitter and receiver are powered on; and check their battery voltage.	Turn on the transmitter and make sure the battery is installed correctly; use a fully charged battery; reinsert the battery.
3	The motor does not working when the throttle joystick is pushed and the receiver alert light begins to flash.	Low helicopter battery voltage.	Charge the battery or replace it with a fully charged battery.
4	After successful binding, the helicopter is started and the main rotor has continuous rotation, but it does not take off.	Low helicopter battery voltage.	Charge the battery or replace it with a fully charged battery.
5	The helicopter is vibrating badly.	The main rotor is deformed, the cross shaft is bent, the tail rotor is deformed, and the rotor clamp screw is locked too tight, causing the main propeller to not move.	Replace the main rotors, replace the cross shaft, and the tail rotor, and loosen the propeller clamp screw properly.
6	The helicopter took off and spun to the left.	The tail motor power is insufficient, the propeller blade is loose, and the tail motor is damaged.	Check the fit of the tail propeller blade and motor shaft, if loose replace the tail propeller blade; if the motor is damaged replace the tail motor.
7	Slight yaw of the aircraft after takeoff:	Misuse of the fine adjustment button	1. Make trims adjustments in the yaw direction until corrected; 2. Reset the hover
8	The helicopter has serious yaw after takeoff.	Check whether the servos are working properly. Check whether the swash plate has problem. Check whether the connecting rod is dropped.	Repair and replace the damaged parts.