

1:12 Electric 4WD Climbing car

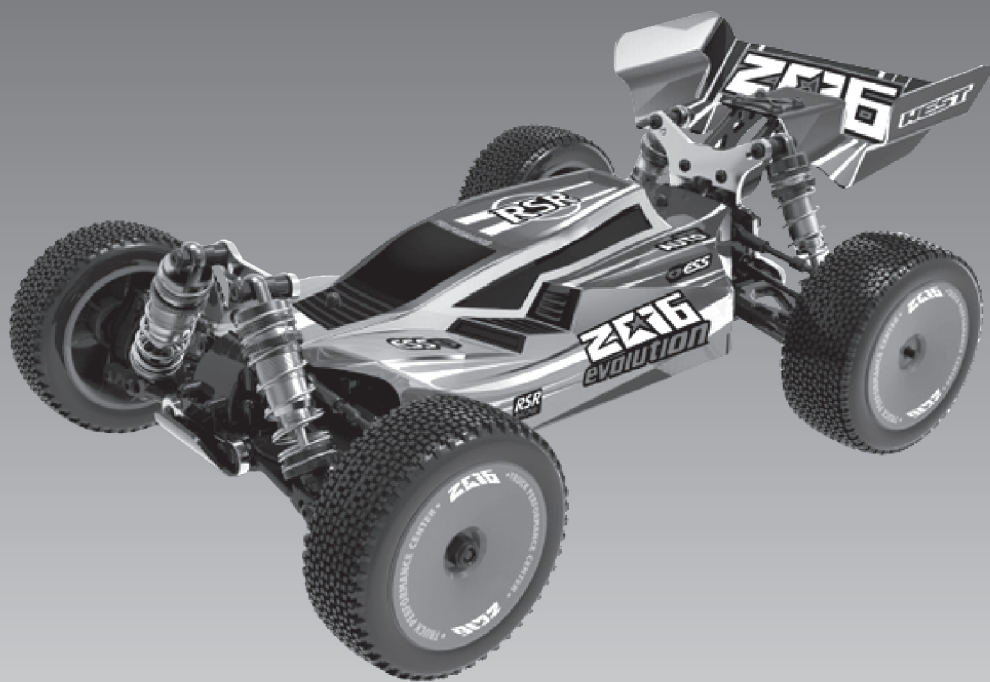

Caution: This model is not a toy, it is designed for user over 14 years of age.
Please use this instruction and the R/C system instruction at the same time.
The instruction is suitable for a type of model whose number is 144001

Safety and caution 1-2

Troubleshooting • Product introduction 2-3

Instruction of common tools and installation the electronic part... 4-5

Practice and maintenance.....5-7

Assemble exploded view8-20

Fittings view21-27

Safety and Cautions

- *Never run the model on public roads or streets, as it could endanger traffic.
- *Never run the model in crowded areas, near or toward people or animals, to prevent property damage and/or personal injury.
- *Never run the model near rivers, ponds or lakes as to prevent R/C car from dropping into the water.
- *Make sure that no one else is using the same frequency as yours in your running area. Using the same frequency at the same time, whether it is driving, flying or sailing, can cause loss of control with R/C model, resulting in serious accidents.
- *To avoid a runaway R/C model or loss of control, always follow the procedure below:
 1. Fully extend transmitter antenna.
 2. Switch on transmitter.
 3. Switch on R/C model.
- *Follow reverse procedure to shut down.
- *Never touch or hinder rotating tire.
- *Never run R/C model in the rain or let run over puddles, as water may cause trouble with R/C model.
- *Motor and battery get very hot after running. Take care when handle them.
- *Retract transmitter antenna when not in use.
- *Remove the batteries from model and transmitter when they are not in use.

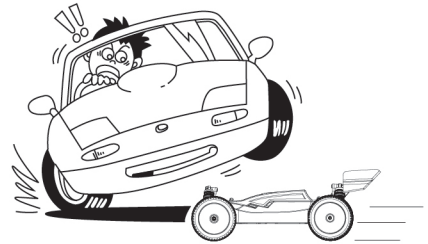

Cautions when handling batteries

- *Do not dismantle the battery or charger and do not cut any battery cables. This may cause short-circuit and/or damage to the product.
- *Change battery with compatible charger following proper procedure that is called out in the instructions. Do not modify charger or charge battery in improper way.
- *Do not recharge battery that is still warm from use as it may damage the battery. Allow the battery to cool off prior to recharging.
- *Make sure to disconnect charger cables from R/C model and electric outlet when not in use.
- *Remove transmitter battery when not using it for a long time as it may leak and damage transmitter when left for a long period.
- *Never incinerate used batteries, as they can explode causing serious accidents.



Safety precautions

Do not operate the model on public roads, in crowded places or near infants, it may cause accidents or injury.

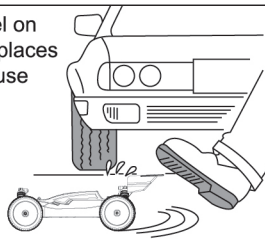

As the product includes small and sharp parts, assemble and store this product only in places out of the reach of children.



As the front end of the antenna may be dangerous, do not aim it toward faces.



During the car running and after, the motor will be hot. Please do not touch it until it has had time to cool down.



Don't use the same frequency with others at the same time. Or the car will lose control or even lead to serious accidents.

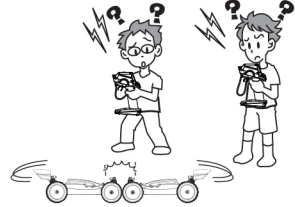

Troubleshooting

Description	Cause	Solution
The car does not operate at all.	Transmitter or receiver is off.	Turn on both transmitter and receiver.
	Batteries are not placed properly in the transmitter.	Place batteries in the transmitter properly.
	The drive battery is not charged enough.	Charge the drive battery.
The car does not follow your operation and control distance not enough long.	Someone else is using the same radio frequency as you are using.	Charge your radio frequency to the one no one else is using, wait until the driver using the same radio frequency finishes driving, or drive your car at a different place.
	There is not enough power in the transmitter or receiver batteries.	Replace the transmitter batteries with new ones and charge the drive battery.
	Not tighten antenna on the transmitter/not fully extend antenna.	Make sure insert antenna into the transmitter and fully extend antenna.



CAUTION

- * Please observe the operation manual or packing explanation to install and use, and some parts should be installed by adults.
- * The product contains small parts, it may cause swallow or choke.
- * Never run an R/C model in the seep or rain, moisture areas, or it may cause the parts malfunction.
- * Please throw the wrapper in time to avoid danger for the children.
- * Regularly examine for damage to the charge, wire, plug, bodyshell or other parts. In the event of any damage, it must not be used until the damage has been repaired.
- * The charge, battery box and battery must insert with the appointed power source of product symbol same.
- * This product must only be used with the original collocation charger.
- * The product is contains the functional outshoots are may be dangerous to the children.

Proportional R/C Using Instruction

- ① Turn left the steering wheel, the car will turn left. Turning left angle can be adjusted by the degree of wheel twisting.

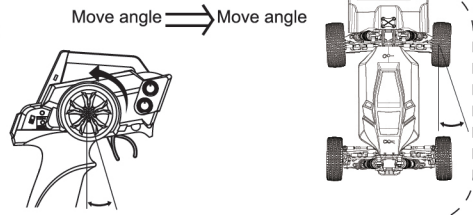

- ② Turn right the steering wheel, the car will turn right. Turning right angle can be adjusted by the degree of wheel twisting.

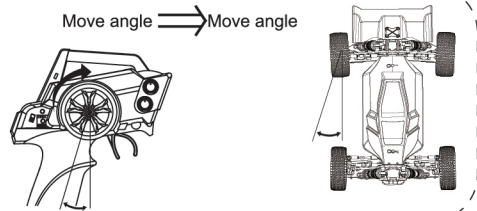

- ③ Pull the throttle trigger backward, the car will forward. Adjusting the angle of throttle trigger can adjust forward speed of the car. During the car forward, quickly push the trigger forward to stop it.

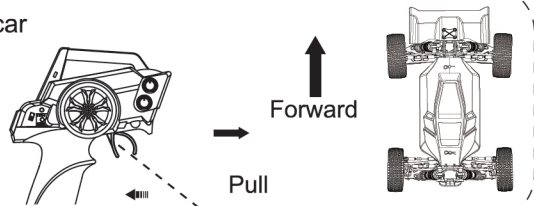

- ④ Loosen the trigger to make it return the neutral position when brake. Push the throttle trigger forward, the car will backward. Adjusting forward angle of throttle trigger adjust backward speed of the car.

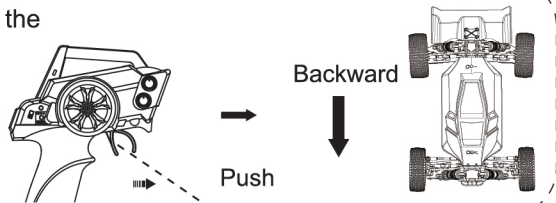

Introduce the common tools and assemble the electron parts

Tools needed for assembly

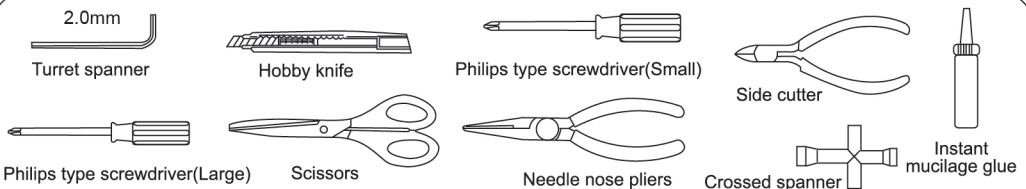

PRACTICE AND MAINTENANCE

Operating program

1. Turn on the power switch **1** on the remote and make sure the power indicator **2** flashes red, then turn on the model car's power switch.
2. The model car on the shelf, gently hook remote control on the trigger **3** to observe whether the car can move forward and backward.
3. Turn the remote control steering wheel **4** to the left or right and make sure that the front wheel's steering follows the command.
4. The model car on the ground, and standing behind the model car, gently hook the remote control throttle trigger **3**, if the model car does not go straight, rotate the remote control front wheel trim **5**, the model car to the right side, the front wheel Turn the trim to the left, the model car leans to the left, and the front wheel trims to the right to rotate until the model car can go straight.
5. Throttle speed adjustment **6** can adjust the model car speed, rotate to the right, hook the trigger model car speed becomes faster, turn left, hook the trigger model car speed becomes slower.
6. OK,ready to run.

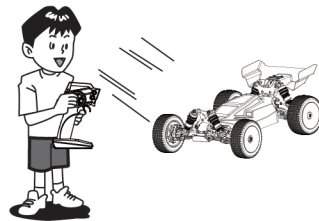
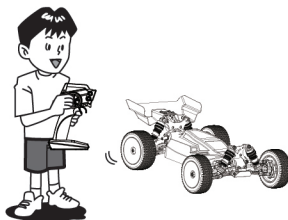
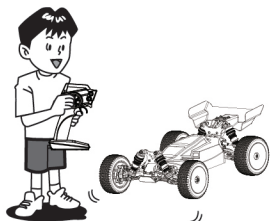
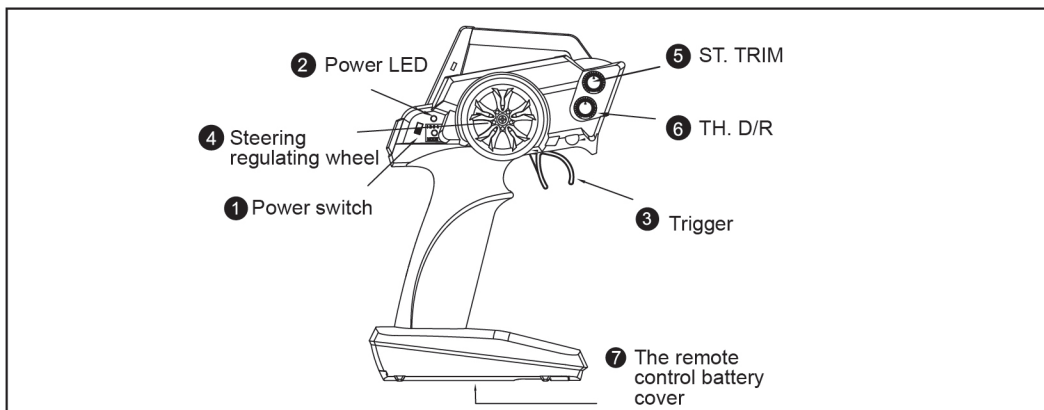

Practice

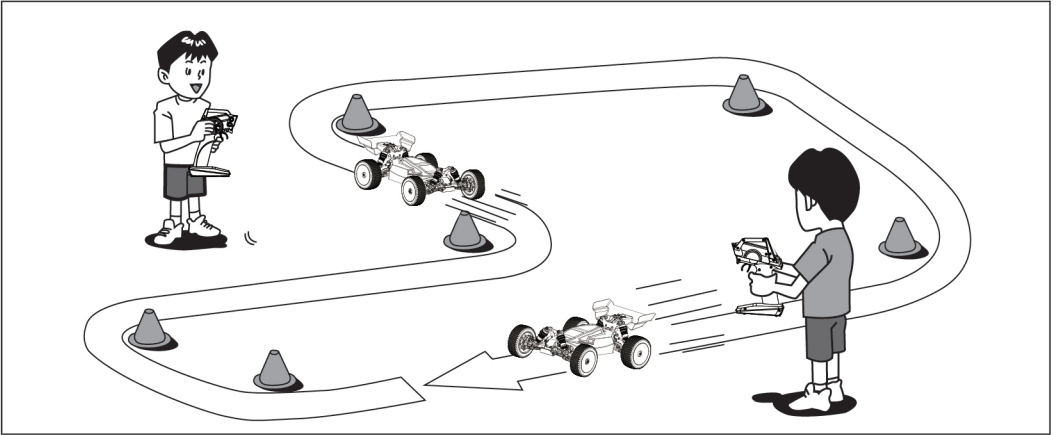

Let's practice! Make R/C car circuit at a wide and safe location using corner pylons (separately available), empty cans or such. Running fast at straight section and slow down at curved section is a basic speed control technique useful when driving R/C car.

Maintain

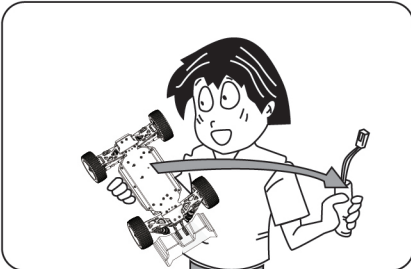

When the car is not in use, you should remove the battery from the car.

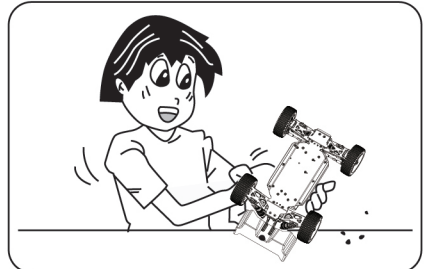

Completely remove sand, mud, dirt etc.

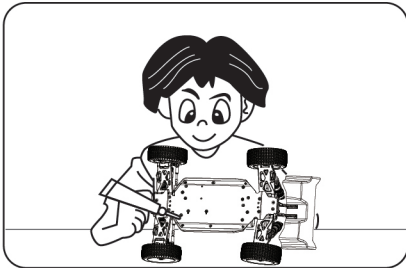

Metal outside should apply the rust prevention oil.

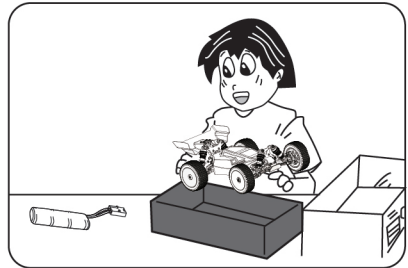

Store the car and batteries separately when not in use.

Assembly Exploded Diagram

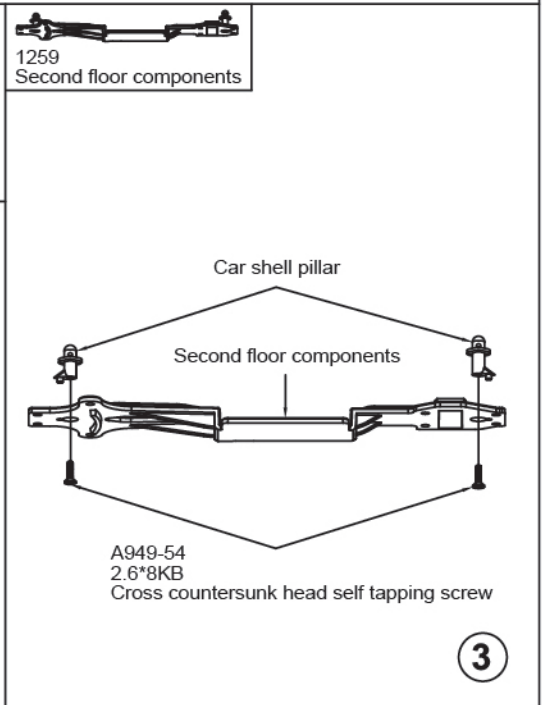
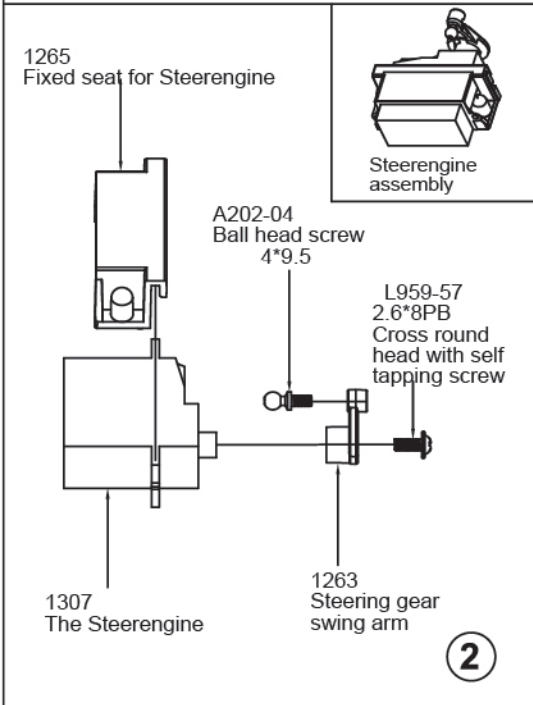
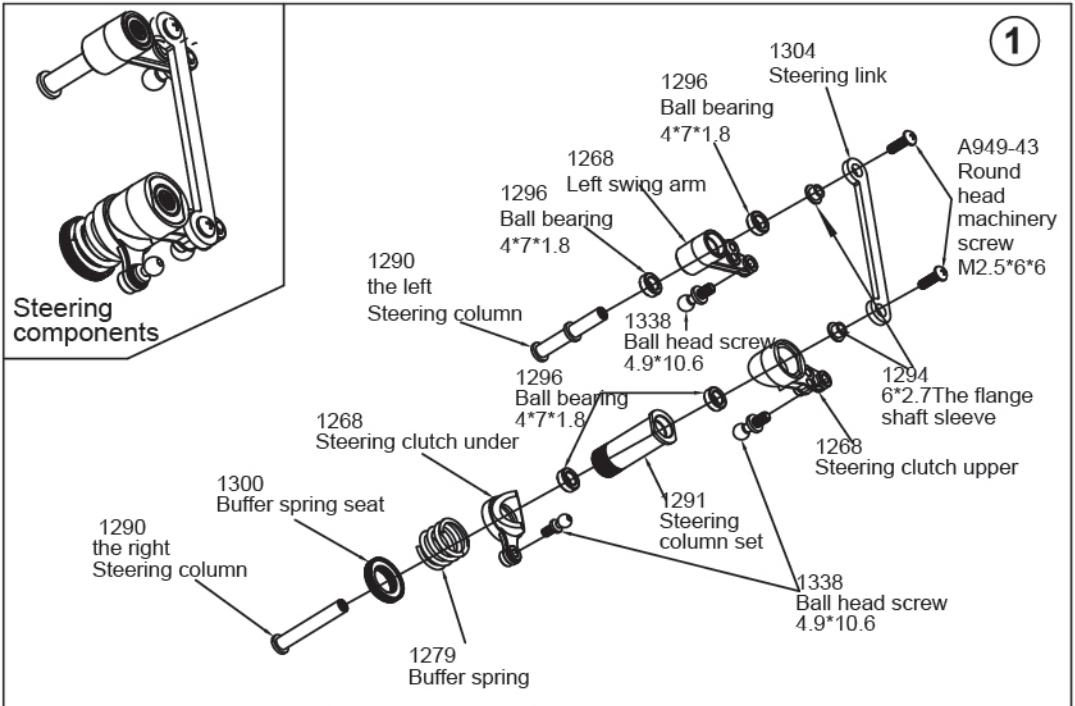

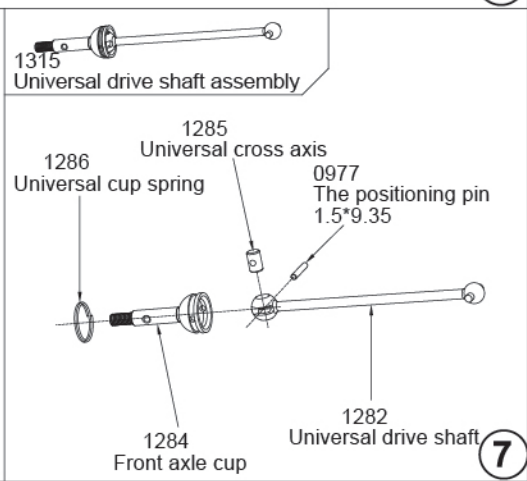
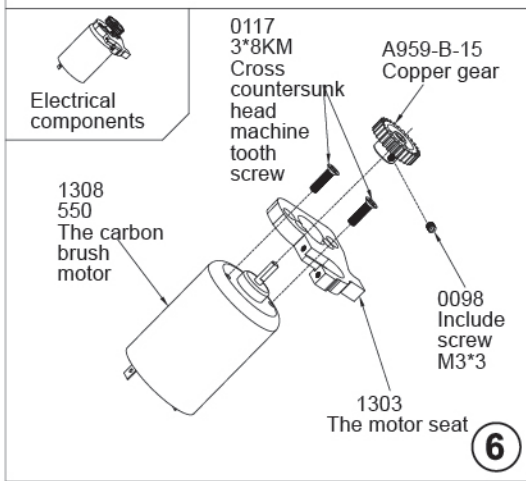
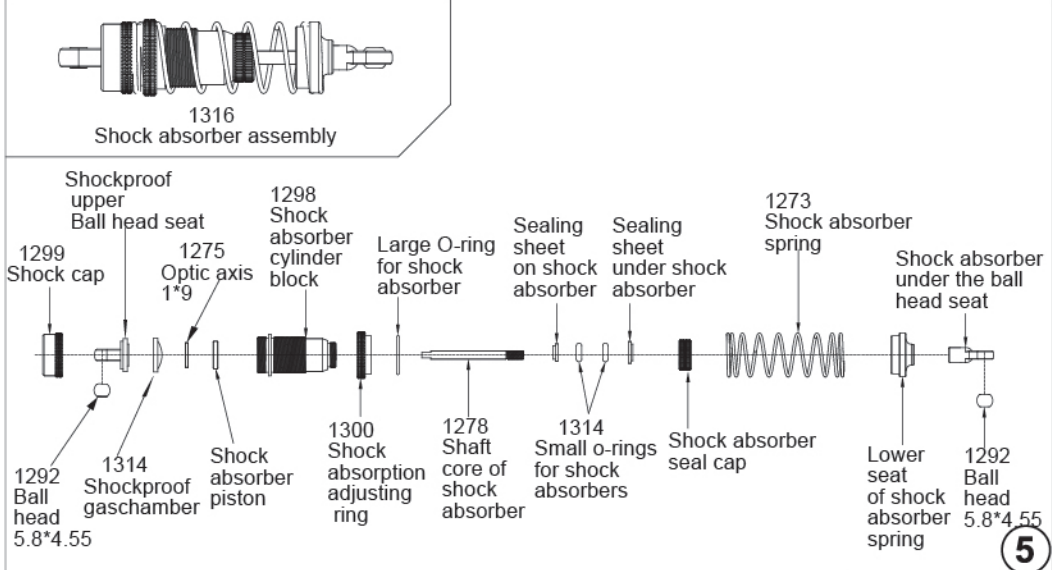
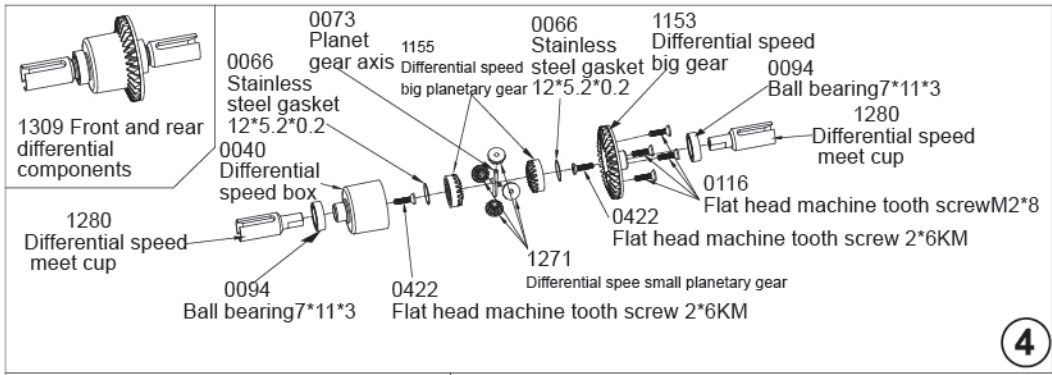

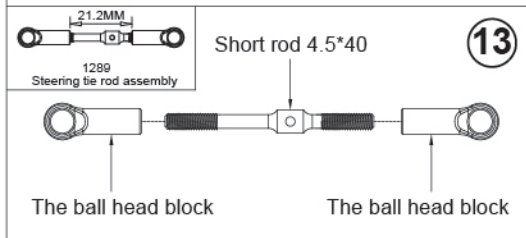
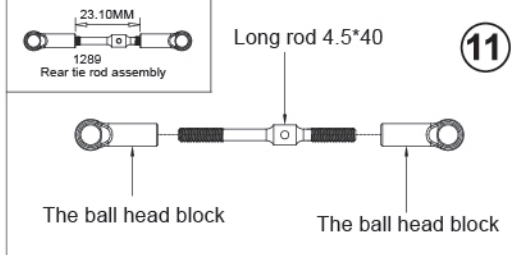
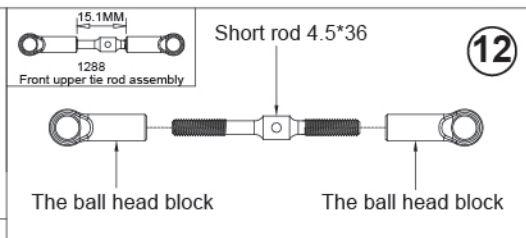
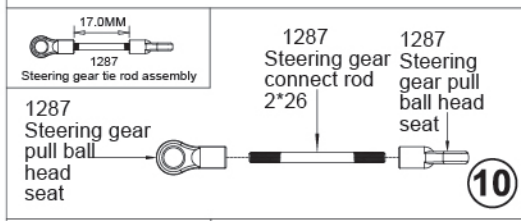
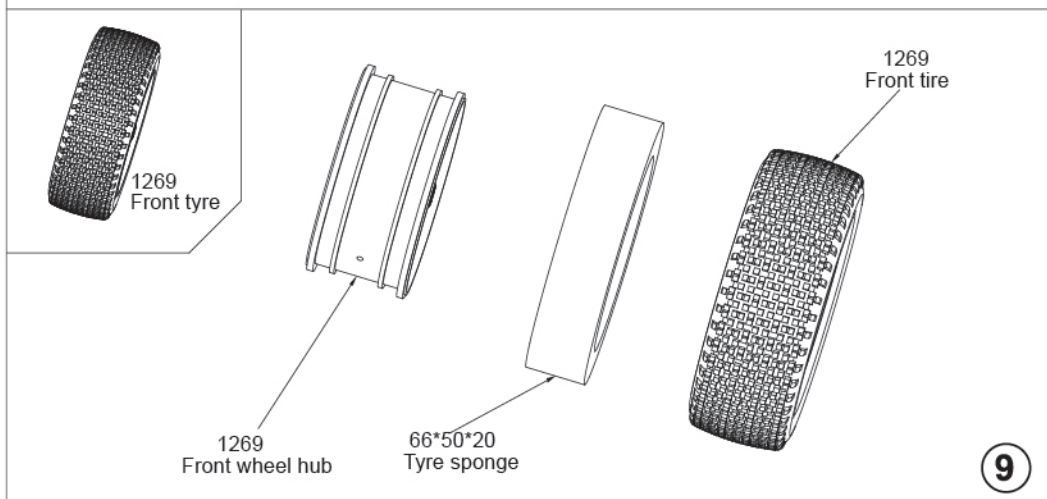
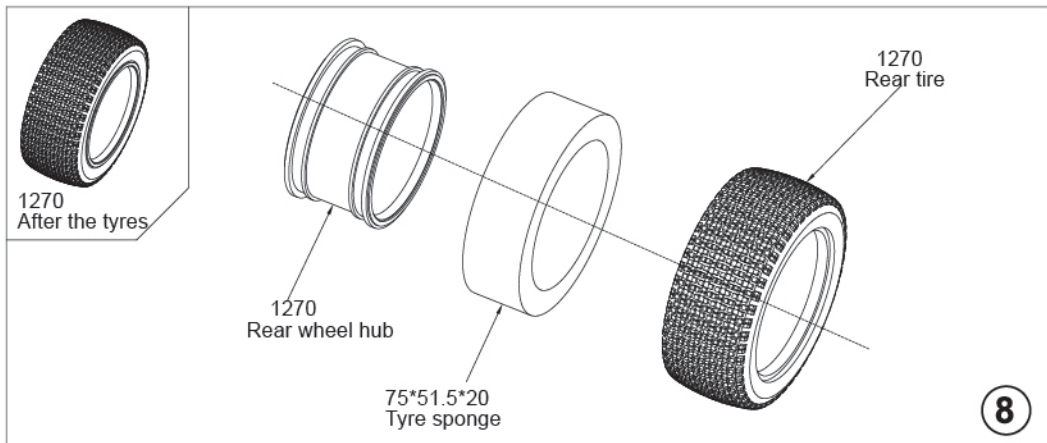



Central drive shaft assembly

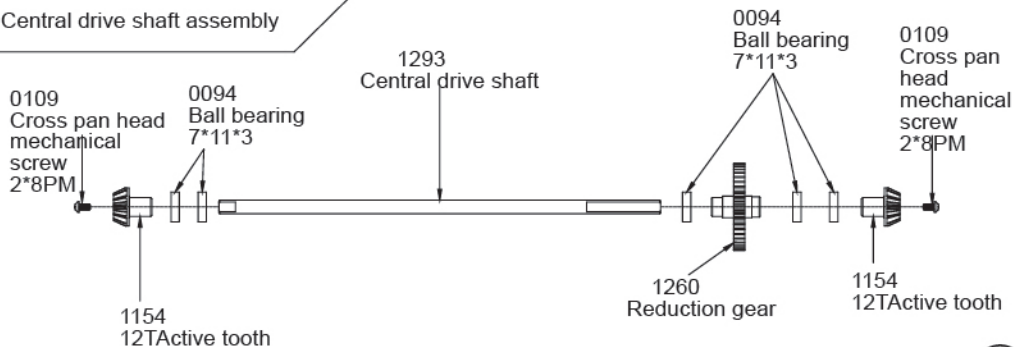

14

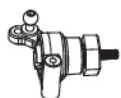

Left rear wheel seat assembly

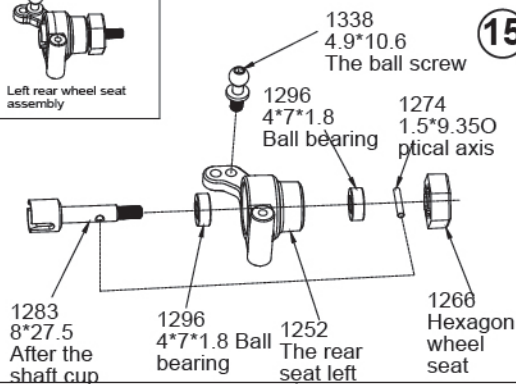

15

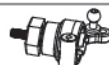

Right rear wheel seat assembly

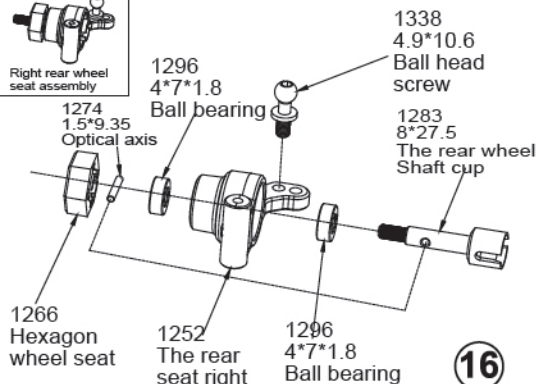

16

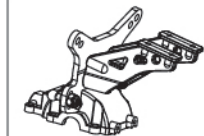

Rear shock absorber assembly

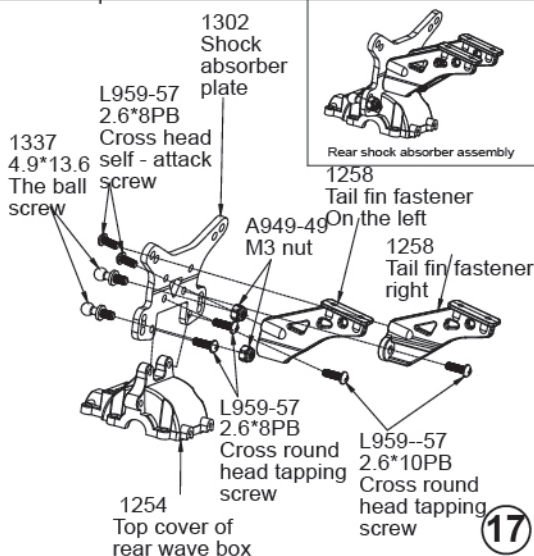

17

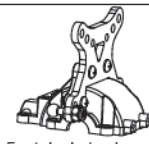

Front shock absorber assembly

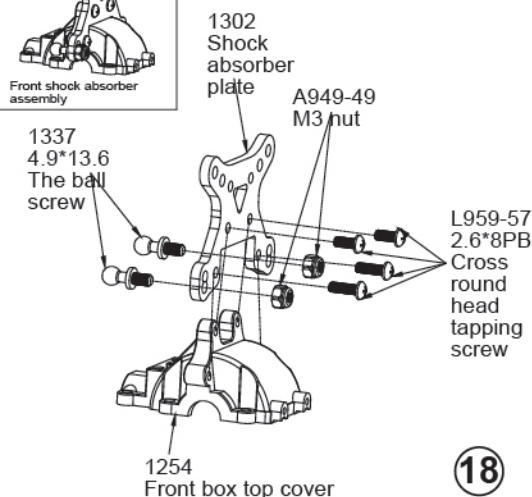

18

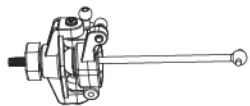

Front right steering seat assembly

0102
2.5*10PM
Cross round
head machine
tooth screw

19

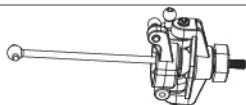
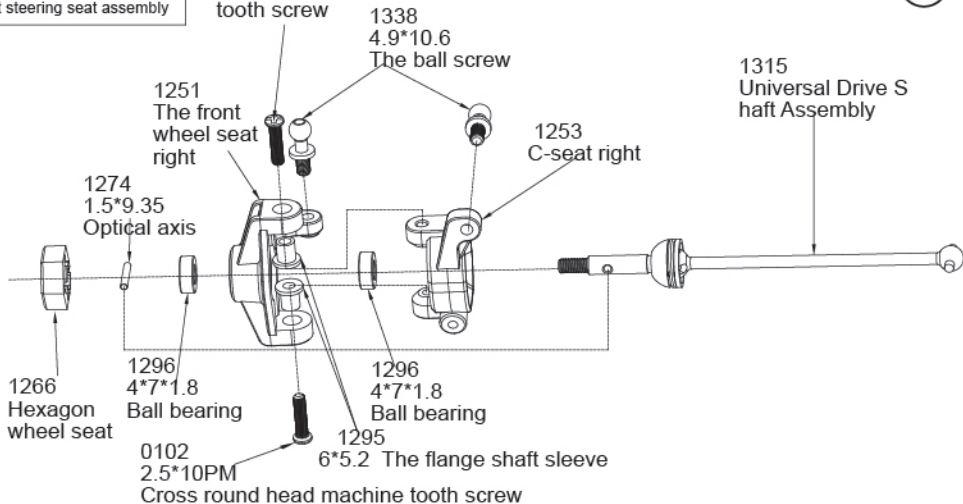

Front turn left to seat assembly

0102
2.5*10PM
Cross round
head machine
tooth screw

20

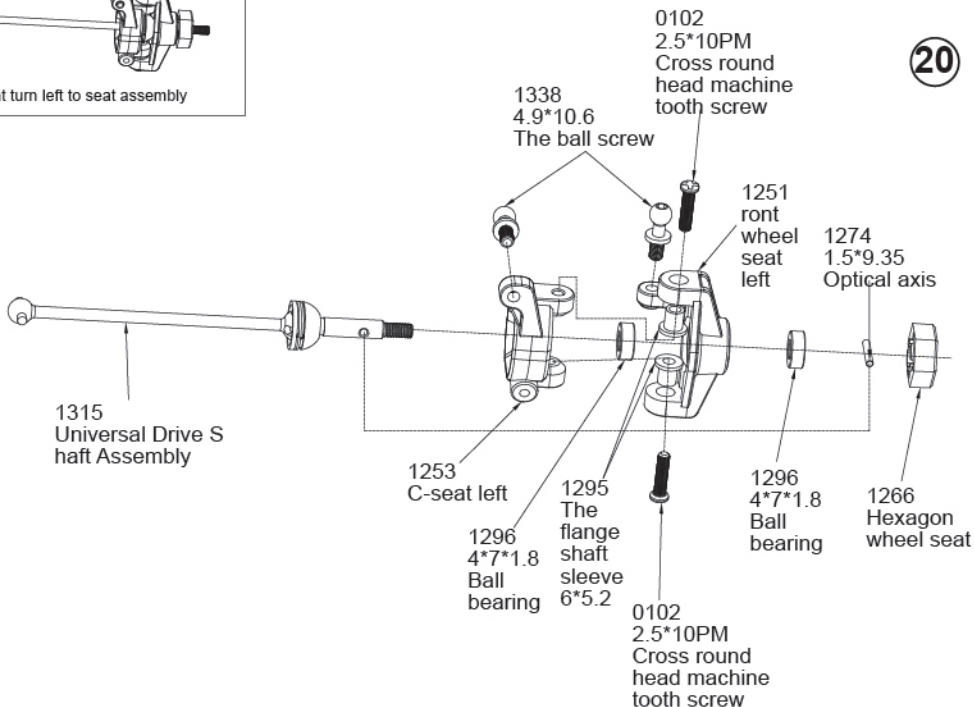

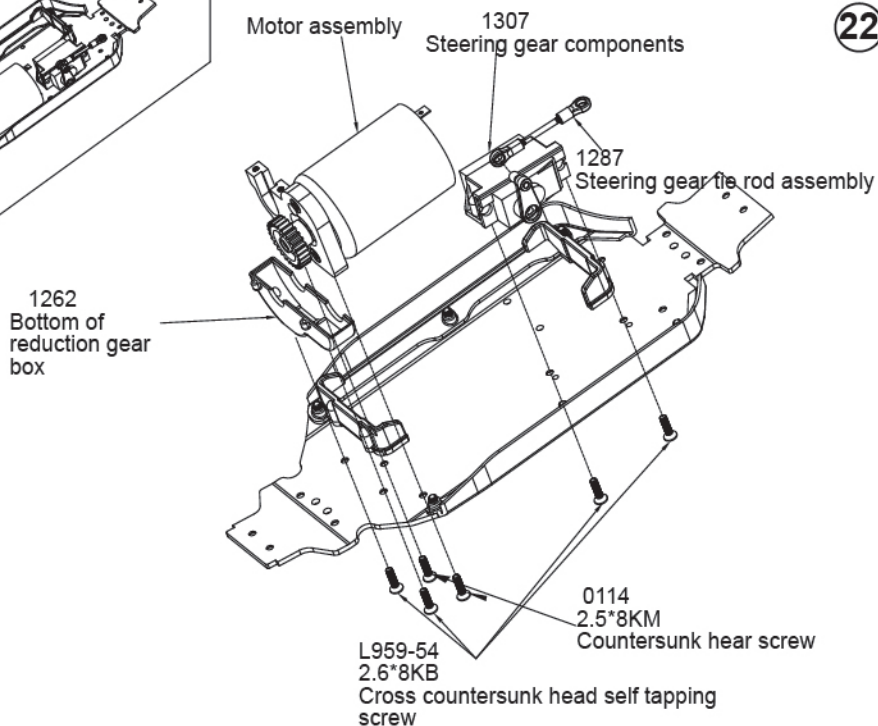
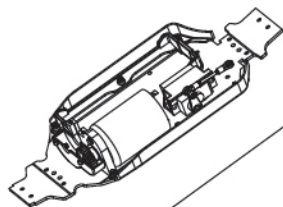
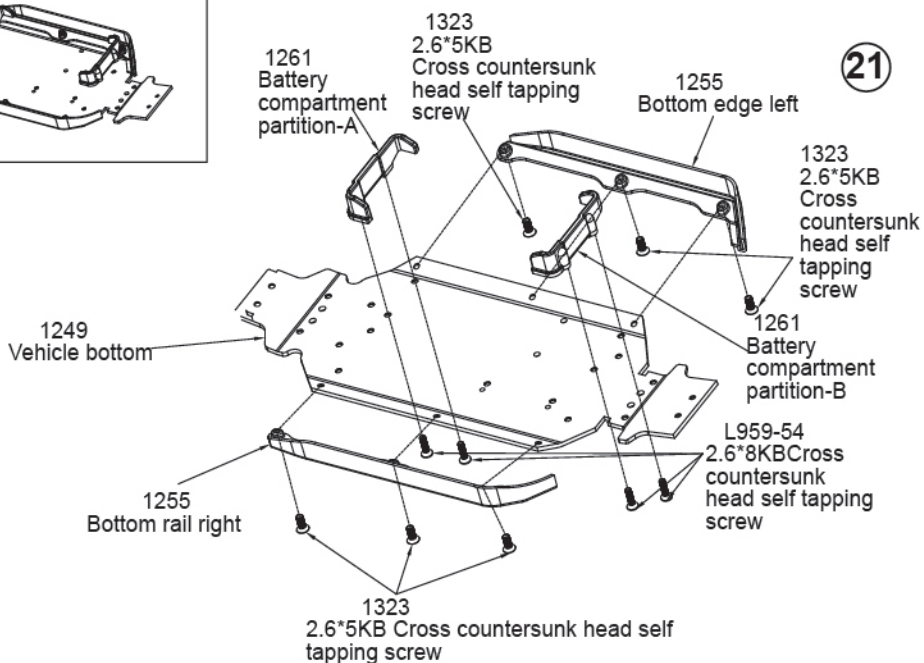
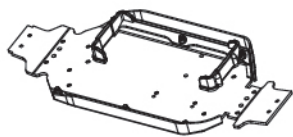

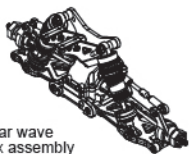

Rear wave box assembly

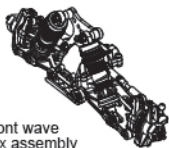
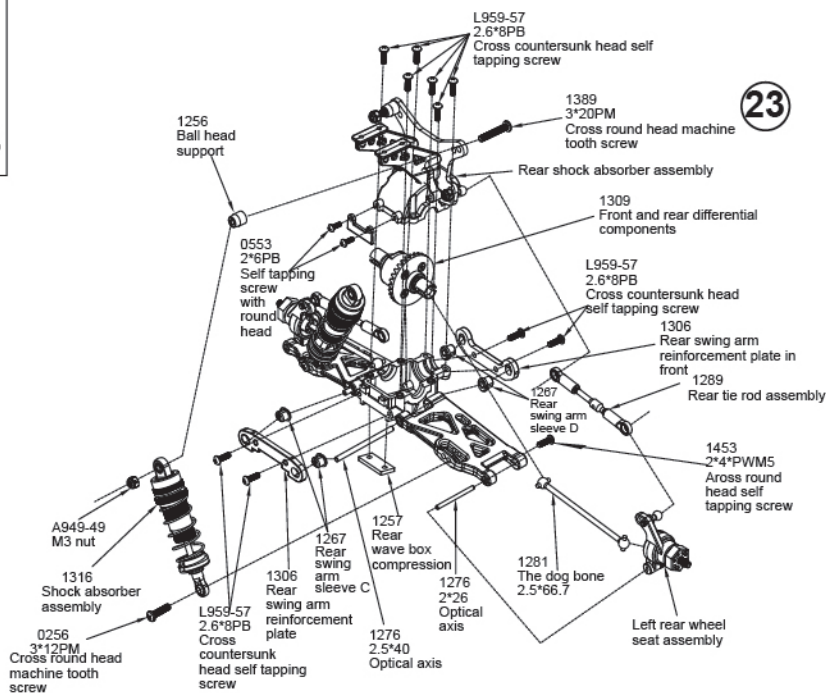

Front wave box assembly

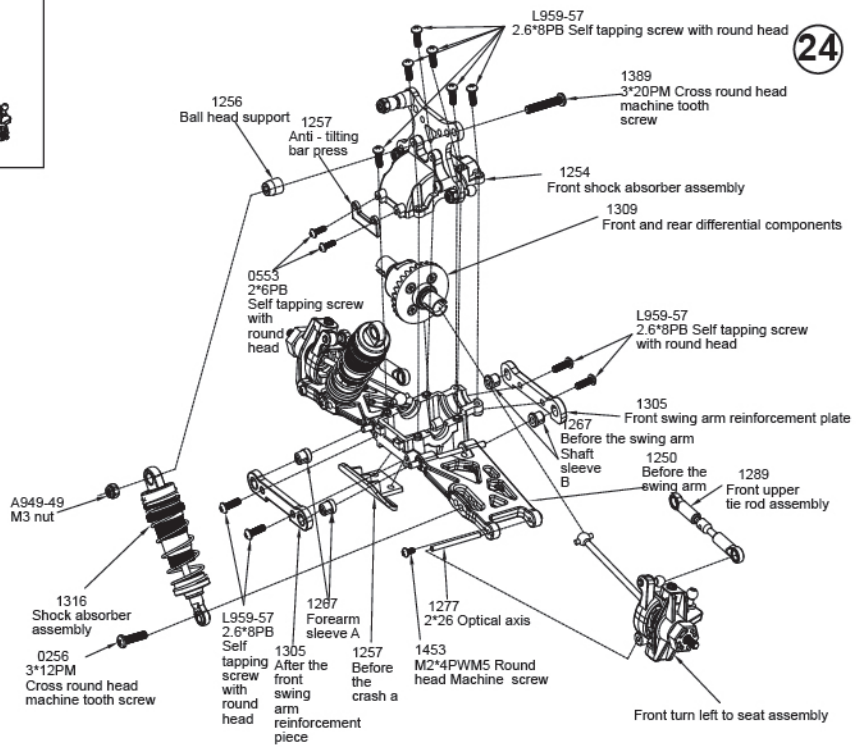

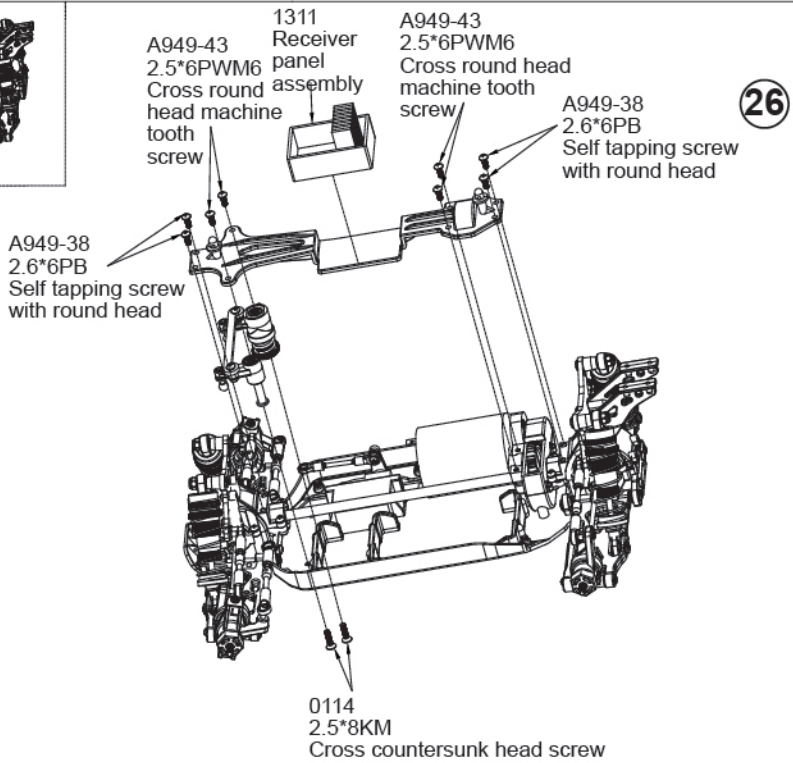
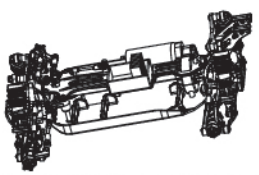
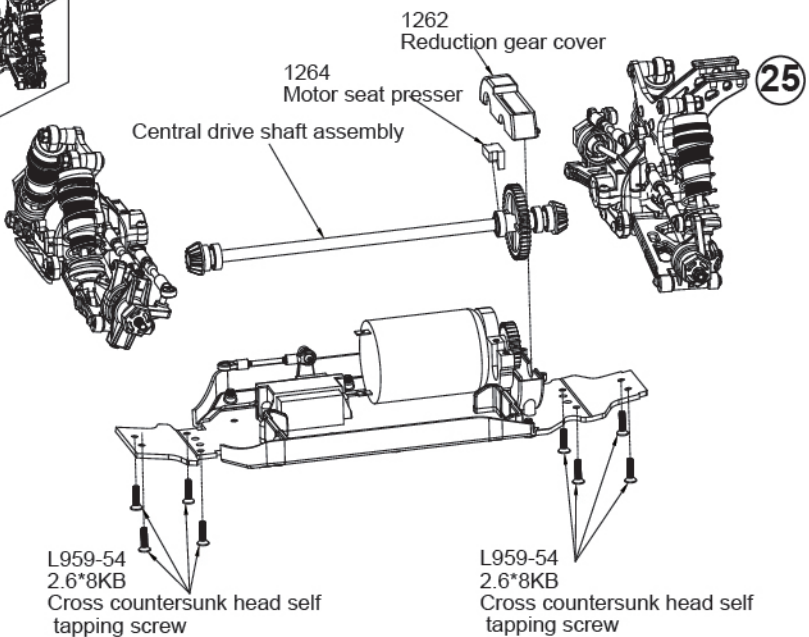
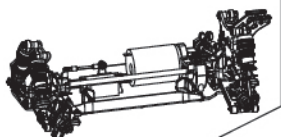

27

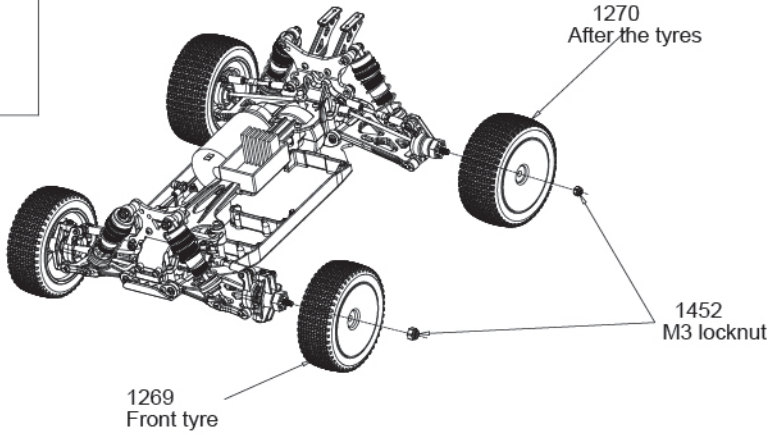
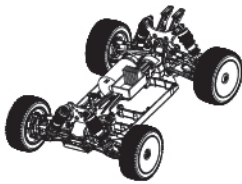

28

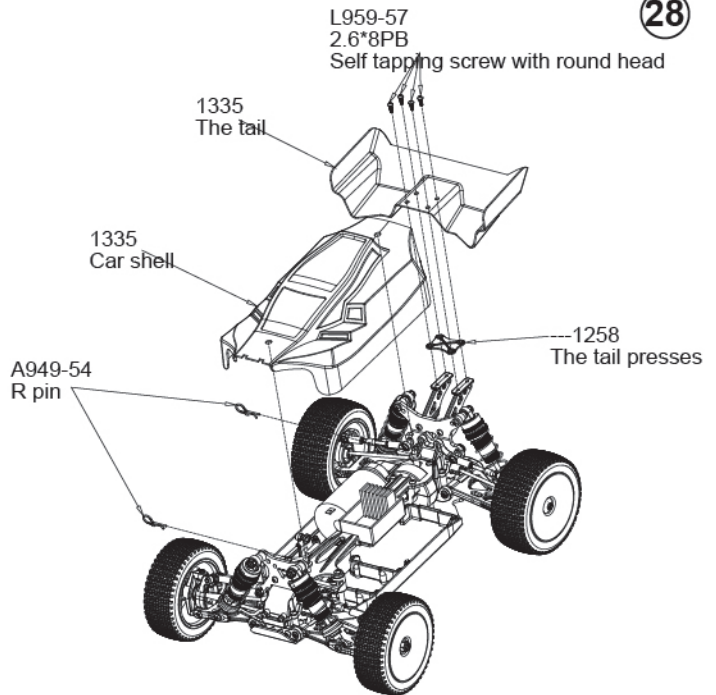
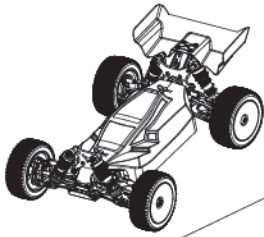

Sale parts view

Sale parts view

Sale parts view

Sale parts view

Sale parts view
